TECHNICAL MANUAL

**OPERATOR'S AND AVIATION INTERMEDIATE
MAINTENANCE (AVIM) MANUAL INCLUDING
REPAIR PARTS AND SPECIAL TOOLS LIST FOR**

ELECTRIC/INSTRUMENT SHOP

**P/N SC-4920-97-CL-A62
NSN 4920-01-139-4534**

HEADQUARTERS, DEPARTMENT OF THE ARMY

13 MAY 1985

CHANGE }
NO. 2 }

HEADQUARTERS
DEPARTMENT OF THE ARMY
WASHINGTON, D.C., 1 November 1988

Operator's and Aviation Intermediate Maintenance (AVIM) Manual
Including Repair Parts and Special Tools List

For

ELECTRIC/INSTRUMENT SHOP

P/N SC-4920-99-CL-A62

NSN 4920-01-139-4534

TM 55-4920-439-13&P, 15 May 1985, is changed as follows:

1. Remove and insert pages as indicated below. New or changed text material is indicated by a vertical bar in the margin. An illustration change is indicated by a miniature pointing hand.

Remove pages

1-1 and 1-2
2-18.1/2-18.2
A-1/A-2

Insert pages

1-1 and 1-2
2-18.1/2-18.2
A-1/A-2

2. Retain this sheet in front of manual for reference purposes.

By Order of the Secretary of the Army:

CARL E. VUONO
General, United States Army
Chief of Staff

Official:

WILLIAM J. MEEHAN II
Brigadier General, United States Army
The Adjutant General

DISTRIBUTION:

To be distributed in accordance with DA Form 12-31, Operator and AVIM Maintenance requirements for All Fixed and Rotary Wing Aircraft.

CHANGE }
NO. 1 }

HEADQUARTERS
DEPARTMENT OF THE ARMY
WASHINGTON, D.C., 29 January 1987

Operator's and Aviation Intermediate Maintenance (AVIM) Manual
Including Repair Parts and Special Tools List

For

ELECTRIC/INSTRUMENT SHOP

P/N SC-4920-99-CL-A62

NSN 4920-01-139-4534

TM 55-4920-439-13&P, 13 May 1985, is changed as follows:

1. On Cover, P/N SC-4920-97-CL-A62 is changed to read P/N SC-4920-99-CL-A62.
2. Remove and insert pages as indicated below. New or changed text material is indicated by a vertical bar in the margin. An illustration change is indicated by a miniature pointing hand.

Remove pages

i/ii
1-1 through 1-4

2-1 and 2-2

2-3 through 2-12
2-15 through 2-18

2-21 and 2-22
2-25 through 2-33/2-34
3-21 and 3-22
A-1/A-2

Insert pages

i/ii
1-1 through 1-4
1-5/1-6
2-1 and 2-2
2-2.1/2-2.2
2-3 through 2-12
2-15 through 2-18
2-18.1/2-18.2
2-21 and 2-22
2-25 through 2-33/2-34
3-21 and 3-22
A-1/A-2

3. Retain these sheets in front of manual for reference purposes.

By Order of the Secretary of the Army:

Official:

JOHN A. WICKHAM, JR.
General, United States Army
Chief of Staff

R. L. DILWORTH
Brigadier General, United States Army
The Adjutant General

DISTRIBUTION:

To be distributed in accordance with DA Form 12-31, Operator and AVIM Maintenance requirements for all Fixed and Rotary Wing Aircraft.

WARNING

PRECAUTIONARY DATA

Personnel performing operations, procedures and practices which are included or implied in this Technical Manual shall observe the following warnings. Failure to observe these warnings and precautionary information can cause serious injury, death or destruction of material.

WARNING

An operating procedure, practice, etc., which, if not correctly followed, could result in personnel injury or loss of life.

CAUTION

An operating procedure, practice, etc., which, if not strictly observed, could result in damage to or destruction of equipment.

NOTE

An operating procedure condition, etc., which is essential to highlight.

WARNING

Four people are needed when moving or lifting the Environmental Control Units (ECUs). Each unit weighs approximately 270 pounds. Trying to move or lift an ECU without sufficient help can cause serious injury to personnel.

WARNING

When all equipment and materiel is stored on the stationary side of the shelter, the limited floor space presents a safety hazard to operating personnel. This is most critical during the raising and lowering of the roof panel. Failure to observe supplemental instructions could result in serious injury to personnel. Personnel inside the shelter could become trapped between the roof panel and equipment bolted to the floor.

WARNING

The two upper lockout pins must be installed at the cable housing prior to raising the shelter floor from its lower position to its level position. If the lockout pins are not in place, the counterbalance cable will remain under tension. DO NOT attempt to remove cable if the upper lockout pins are not installed. Removing cable while under tension could cause serious injury to personnel

WARNING

HIGH VOLTAGE exists in the electrical system of the shop. All electrical inspections, repairs or replacement will be performed with the power off and only by qualified electricians. Serious shock hazards exist which could result in injury or even death to personnel.

WARNING

Methylethylketone (MEK), used to clean replacement inserts, is flammable and toxic. Use only in well ventilated areas. Breathing vapors can cause headaches and nausea. Repeated contact with skin can cause irritation. If irritation persists see a doctor. Contact with eyes, wash immediately with water for 15 minutes and seek medical attention.

WARNING

Safety goggles will be worn when drilling and cleaning holes for insert replacement. Flying chips can cause eye injury or even blindness.

WARNING

Make sure compressed air supply is disconnected before attempting any work on the water/oil separator. Do not direct compressed air near eyes or directly against skin. Wear goggles; high pressure air against eye can cause blindness.

WARNING

Extreme care must be taken when performing all types of welding operations. Serious health and fire hazards exist. Harmful light rays can cause eye injury or even blindness. Protective face masks and goggles must be used as well as other special clothing to reduce risks. Poisonous fumes, burns, and electric shock, fire, and explosion hazards are some of the additional possibilities of injury associated with welding operations. It is essential that all safe practices be strictly observed.

CAUTION

Care must be taken to ensure that the proper bolts and washers are available to secure equipment when shop is to be transported. Lack of correct hardware could cause extensive damage to equipment or the shelter when the shop is moved.

CAUTION

Ensure that the power cable is not twisted, kinked or laid over sharp rocks or projections. Where possible cable should not be routed through any deep ground depressions where water may accumulate.

CAUTION

Torque values provided must be respected to prevent possible damage to equipment or the shelter. Improper procedures could result in extensive damage to Government property.

OPERATOR'S AND AVIATION INTERMEDIATE
MAINTENANCE MANUAL
INCLUDING
REPAIR PARTS AND SPECIAL TOOL LIST
FOR THE ELECTRIC/INSTRUMENT SHOP

REPORTING ERRORS AND RECOMMENDING IMPROVEMENTS

You can help improve this manual. If you find any mistake or if you know of a way to improve the procedures, please let us know. Mail your letter, DA Form 2028 (Recommended Changes to Publications and Blank Forms), or DA Form 2028-2 located in the back of this manual direct to: Commander, US Army Aviation Systems Command, ATTN: AMSAV-MPSD, 4300 Goodfellow Blvd., St. Louis, Missouri 63120-1798. A reply will be furnished directly to you.

	Page
CHAPTER 1. INTRODUCTION	1-1
SECTION I. General Information	1-1
SECTION II. Equipment Description and Data.....	1-2
SECTION III. Principles of Operation	1-5
CHAPTER 2. OPERATOR INSTRUCTIONS	2-1
SECTION I. Initial Shop Setup.....	2-1
SECTION II. Preparing Shop for Operation	2-3
SECTION III. Preparation for Shipment.....	2-20
CHAPTER 3. MAINTENANCE INSTRUCTIONS, AVIM.....	3-1
SECTION I. Repair Parts, Special Tools, TMDE, and Support Equipment	3-1
SECTION II. Service Upon Receipt.....	3-1
SECTION III. Maintenance Procedures.....	3-2
APPENDIX A REFERENCES	A-1
APPENDIX B MAINTENANCE ALLOCATION CHART.....	B-1
APPENDIX C REPAIR PARTS AND SPECIAL TOOLS LIST.....	C-1
Functional Group Numbers	
01 - Insert Fasteners	
02 - Fixtures	
03 - Electrical	
04 - Special Brackets and Fabricated Components	
05 - Floor Insert Plugs	
APPENDIX D EXPENDABLE/DURABLE SUPPLIES AND MATERIELS LIST.....	D-1
APPENDIX E ILLUSTRATED LIST OF MANUFACTURED ITEMS.....	E-1
APPENDIX F TORQUE LIMITS	F-1
ALPHABETICAL INDEX.....	Index 1

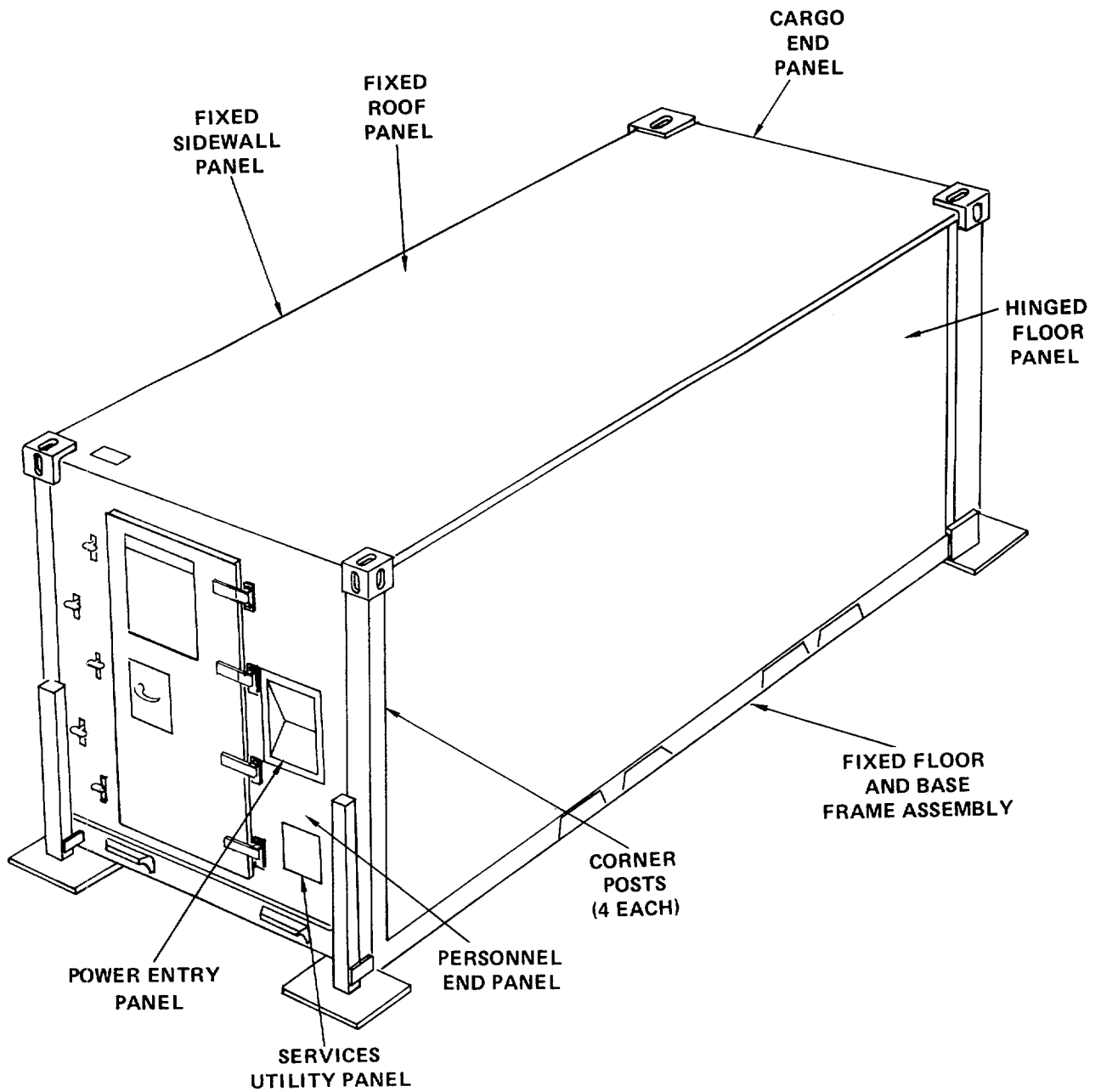

CHAPTER 1 INTRODUCTION

SECTION I. GENERAL INFORMATION

1-1. Scope.

Type of Manual: Operator and Intermediate Level

Equipment Name: Electric/Instrument Shop, NSN 4920-01-139-4534.

Purpose of Equipment: To provide instrument and electric repair in support for non-divisional aviation units. This shop is utilized in conjunction with other maintenance shops in the AVIM support unit.

1-2. Maintenance forms, records and reports.

Department of the Army forms and records used to maintain this equipment will be those prescribed by DA PAM 738-751, The Army Maintenance Management System - Aviation (TAMMS-A).

1-3. Reporting equipment improvement recommendations (EIR).

If your Electric/Instrument Shop needs improvement, let us know. Send us an EIR. You, the user, are the only one who can tell us what you don't like about your equipment. Let us know why you don't like the design. Put it on an SF 68 (Quality Deficiency Report). Mail it to: Commander, U.S. Army Aviation Systems Command, ATTN: AMSAV-MMD, 4300 Goodfellow Blvd., St. Louis, MO 63120-1798. We will send you a reply.

1-4. Destruction of Army materiel to prevent enemy use.

Instructions for destruction of this equipment are contained in TM 750-244-14, Procedures for Destruction of Aviation Ground Support Equipment (FSC 4920), to Prevent Enemy Use.

1-5. Preparation for storage or shipment.

For general technical information on preparation for storage and shipment refer to TM 55-1500-204-25/1 and TM 743-200-1. For regulatory requirements pertaining to equipment placed in administrative storage refer to AR 750-1.

SECTION II. EQUIPMENT DESCRIPTION AND DATA

1-6. Characteristics.

- a. The Electric/Instrument Shop is housed in a tactical, one side expandable, shelter (NSN 5411-01-124-1377).
- b. Once the shelter has been erected the additional floor space provides the work area necessary for the Electric/Instrument Shop to perform its maintenance function.
- c. The shop is equipped with tools, machines and equipment necessary to provide instrument and electrical repair for the AVIM unit.
- d. The shelter can be transported by highway, rail, marine or air (C-130, C-141 or C-5 aircraft, Army CH-47 and CH-54 helicopter).
- e. As designed, the Electric/Instrument Shop can be operated in any geographic area and under any climatic condition in support of Army non-divisional units.

1-7. Location and description of major components.

- a. Shelter closed for transport or storage.
- b. Equipment, location in transport/storage mode.

- (1) ECU
- (2) CABINET, BIN STORAGE
- (3) VISE
- (4) EXHAUST GAS TESTER
- (5) SMALL CABINET, W/DRAWERS
- (6) CABINET, BIN STORAGE (STACKED)
- (7) GRINDER
- (8) CABINET, W/DRAWERS
- (9) DRILL PRESS
- (10) D.C. POWER SUPPLY
- (11) TOOL BOX RACK

NOTE

ITEM (4) MAY NOT BE ISSUED WITH THIS SHOP SET, BUT IF REQUIRED, CAN BE OBTAINED BY SEPARATE REQUISITION.

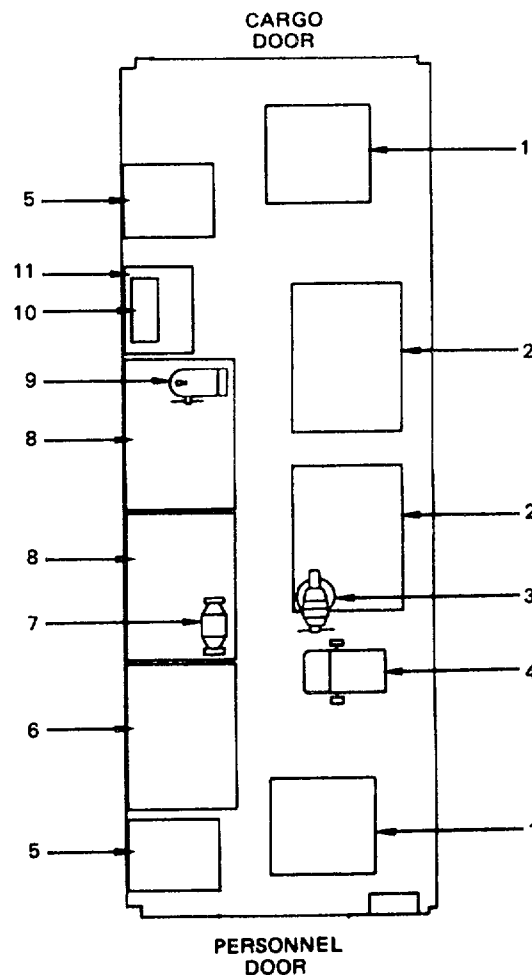

c. Equipment location in operational mode (for shelter P/N 136-0000-101.)

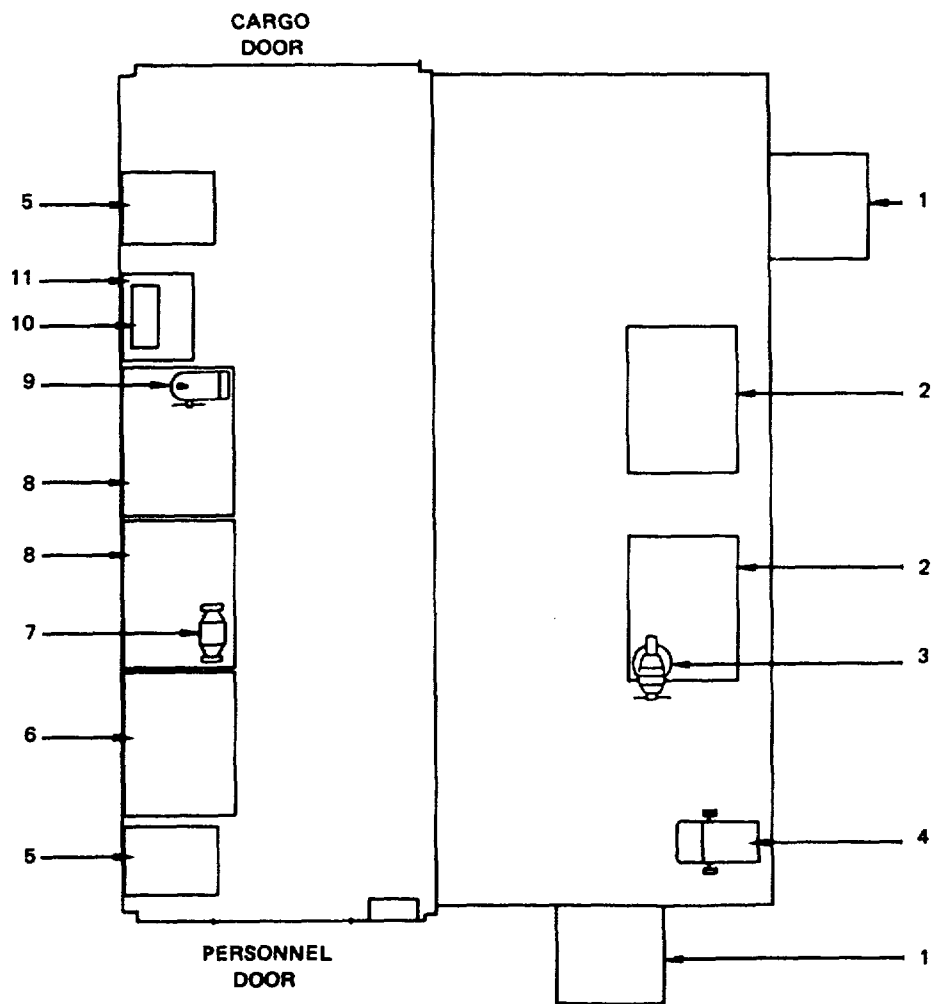

- (1) ECU
- (2) CABINET, BIN STORAGE
- (3) VISE
- (4) EXHAUST GAS TESTER
- (5) SMALL CABINET, W/DRAWERS
- (6) CABINET, BIN STORAGE (STACKED)

- (7) GRINDER
- (8) CABINET, W/DRAWERS
- (9) DRILL PRESS
- (10) D.C. POWER SUPPLY
- (11) TOOL BOX RACK

d. Equipment location in operational mode (for shelter P/N 5-4-2828-1).

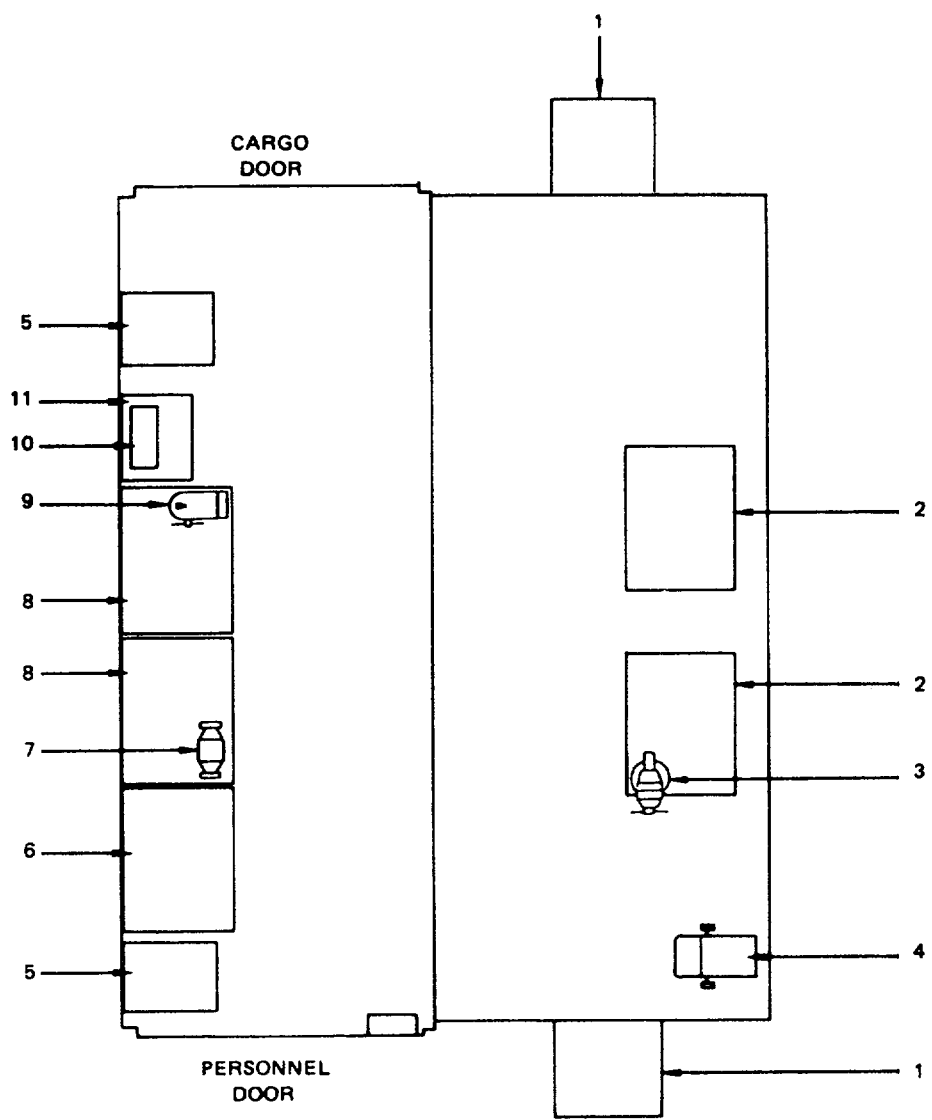

- | | |
|------------------------------------|------------------------|
| (1) ECU | (7) GRINDER |
| (2) CABINET, BIN STORAGE | (8) CABINET, W/DRAWERS |
| (3) VISE | (9) DRILL PRESS |
| (4) EXHAUST GAS TESTER | (10) D.C. POWER SUPPLY |
| (5) SMALL CABINET, W/DRAWERS | (11) TOOL BOX RACK |
| (6) CABINET, BIN STORAGE (STACKED) | |

SECTION III. PRINCIPLES OF OPERATION

1-8. After the shelter has been erected, the operator personnel will unbolt selected items of equipment. These items will be relocated to preselected positions on the expanded side of the shelter. (See para. 1-7c. and d.). The selected items, when moved, will not be secured, (bolted) in place. This allows the shop personnel a certain flexibility in the event long or bulky materiel must be repaired within the shelter. The recommended locations were selected for proper utilization of floor space and maximum safety for the operating personnel

WARNING

Four people are needed when moving or lifting the Environmental Control Units (ECUs). Each unit weighs approximately 270 pounds. Trying to move or lift an ECU without help can cause serious injury to personnel.

1-9. The two ECUs are positioned on special fold down shelves, when the shop is in the operational mode. Power is provided by a 208V cable located inside the shelter next to each shelf. Both ECUs can be easily removed for service or repair.

1-10. Detailed instructions for unbolting equipment and the recommended sequence for relocation is contained in Chapter 2, Section II. The procedures for striking the shelter and preparing the Electric/Instrument Shop for transport or storage are contained in Chapter 2, Section III.

1-11. Electrical power to operate the Electric/Instrument Shop is provided by an auxiliary generator or a commercial power source. A power distribution panel (PDP) is used between the power source and the power entry panel of the shelter. Overload protection is by circuit breaker. The circuit breaker panel is located inside the shelter next to the personnel entrance door.

CHAPTER 2 OPERATOR INSTRUCTIONS

SECTION I. INITIAL SHOP SETUP

2-1. Setup of Electric/Instrument Shop upon initial receipt. Refer to TM 10-5411-201-14 for specific procedures concerning erection of the tactical, one side expandable, shelter (NSN 5411-01-124-1377).

a. The Electric/Instrument Shop should be set up with power cable length, tactical deployment, exhaust/inlet of ECUs and phasing between related shops kept in mind. The shop's power entry panel, next to the personnel entrance door, should be facing toward the power source and power distribution panel (see page 1-0).

b. Initial Leveling. Procedures in TM 10-5411-20-14 will be followed to ensure proper operation of all fold out panes.

WARNING

When all equipment and materiel is stored on the stationary side of the shelter, the limited floor space presents a safety hazard to operating personnel. This is most critical during the raising and lowering of the roof panel. Failure to observe supplemental instructions could result in serious injury to personnel. Personnel inside the shelter could become trapped between the roof panel and equipment bolted to the floor.

c. Supplemental Safety Instructions. To prevent possible accidents, the following procedures will be followed:

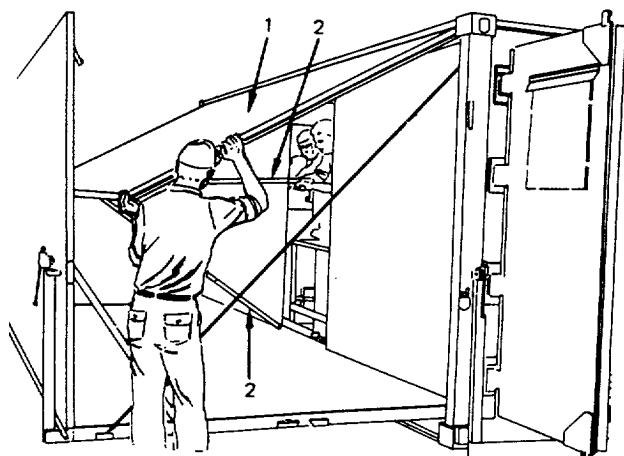

1. Two personnel, outside the shelter, must lift the roof panel (1) far enough to allow two people inside to release the support struts (2), extend them to full length, and insert the quick-release pins (3).

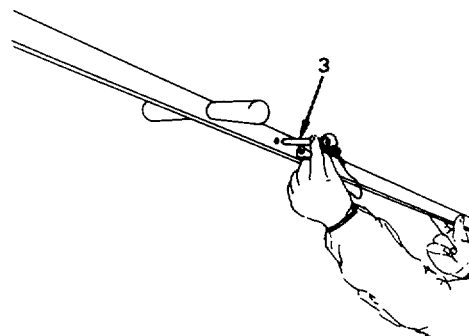

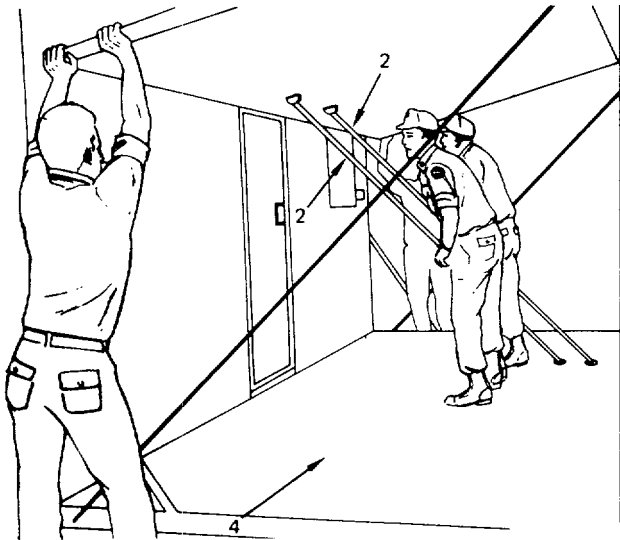

2. As soon as there is enough floor area (4), the personnel inside will move to the expanded side of the shelter raising the roof with extended support struts (2).

3. Once the struts (2) are totally supporting the roof panel (1), the end walls (5) are swung open.

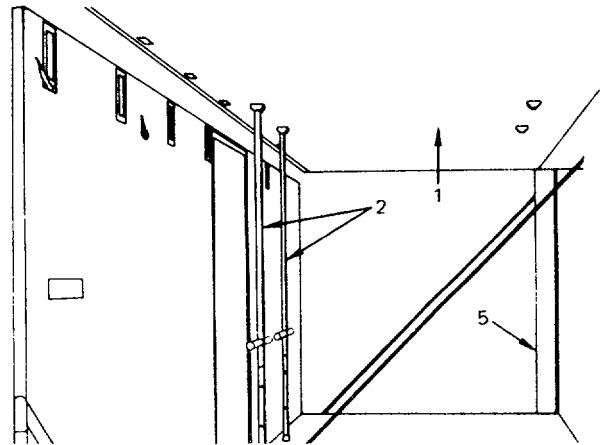

WARNING

The fold-out floor counterbalance cables must be secured in the cable housings prior to raising the shelter floor from its lowered position to its level position. If the counterbalance cables are not secured, the counterbalance cables will remain under tension. **DO NOT** attempt to remove cables if the counterbalance cables are not secured. Removing cables while under tension could cause serious injury to personnel.

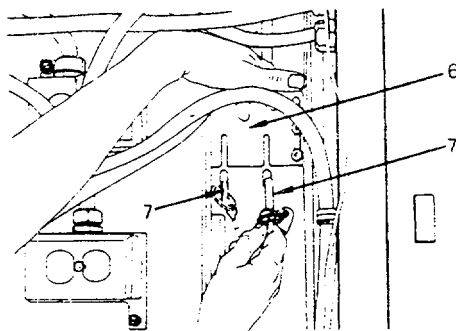

4. (For shelter P/N 136-0000-101) Raise the upper lockout plates (6) on each end wall and install upper lockout pins (7) into the cable housings.

5. (For shelter P/N 5-4-2828-1) Close slide stops (1) against counterbalance cables (2) on both cable reels (3).
6. Securing the counterbalance cables will allow removal of the counterbalance cables attached to each end of fold-out floor.
7. Continue with remaining procedures outlined in TM 10-5411-201-14 for final erection of the shelter.

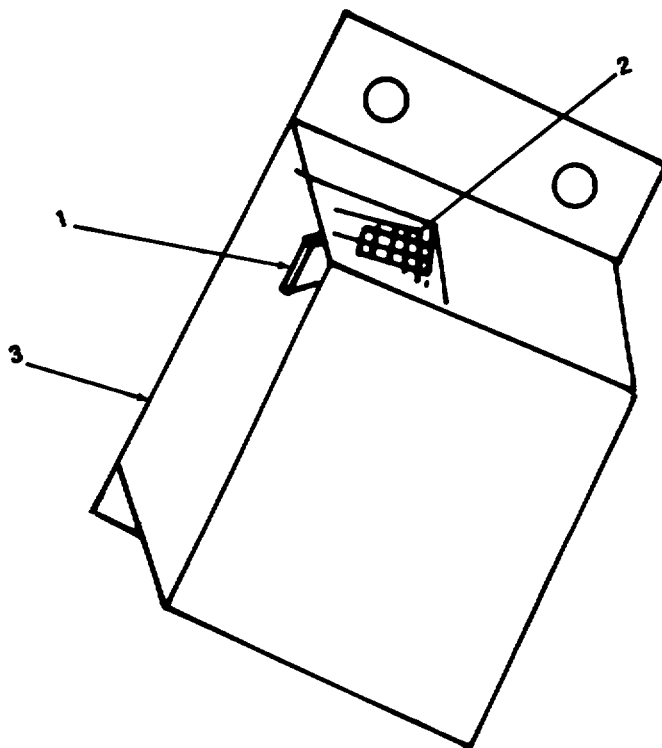

d. Counterbalance Cable Removal.

1. After shop erection is complete (AND COUNTERBALANCE CABLES ARE SECURED), remove three screws (1) from cable retainer block (2).

2. Let cable (3) and retainer block (2) hang loose next to shelter (4).

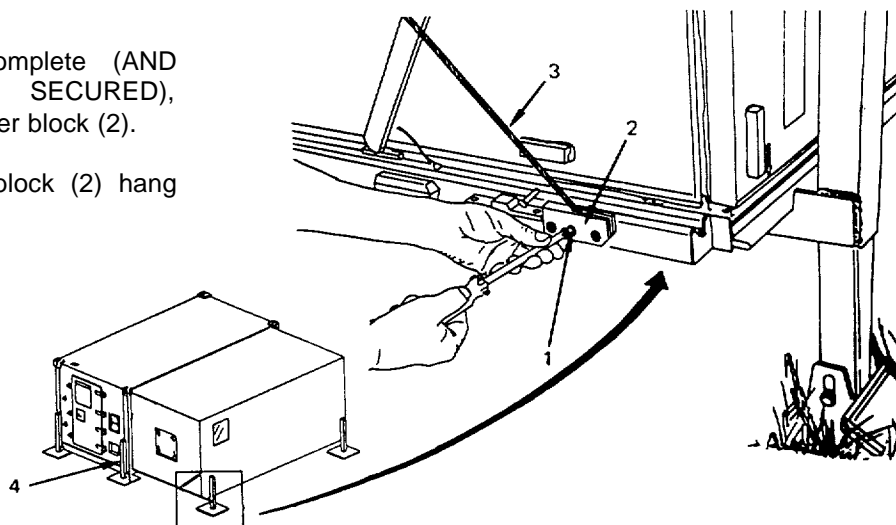

3. Reinstall retainer block screws (1) and secure.

e. Shop is now ready for reconfiguration of equipment to operational mode.

NOTE

All equipment or tools secured to the floor or walls of the shelter must be carefully tightened to specific torque limits. See Appendix F.

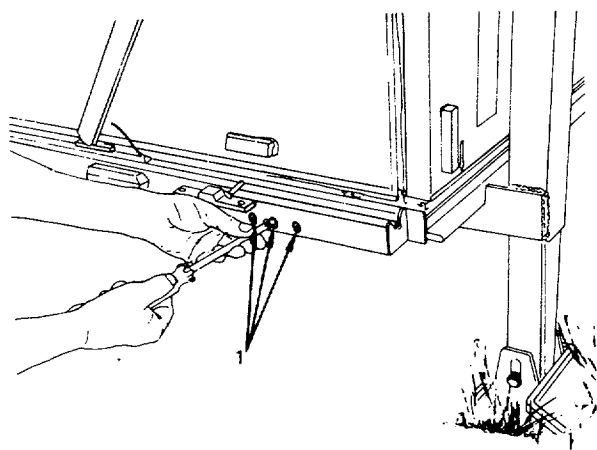

SECTION II. PREPARING SHOP FOR OPERATION

2-2. ECU Shelves, lowering procedures.

NOTE

(For shelter P/N 136-0000-101) One ECU opening is located in the fold-out end wall and one ECU opening is located in the fold-out side wall. (For shelter P/N 5-4-2828-1) Both ECU openings are located in the fold-out end walls. One ECU opening in each fold-out end wall.

a. Remove four plugs (1) on outside of each shelf (2).

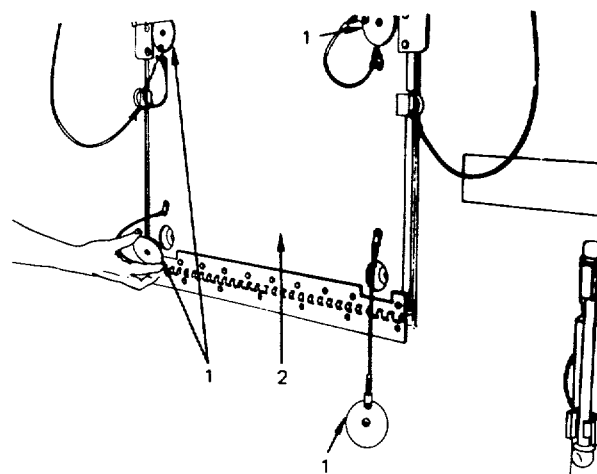

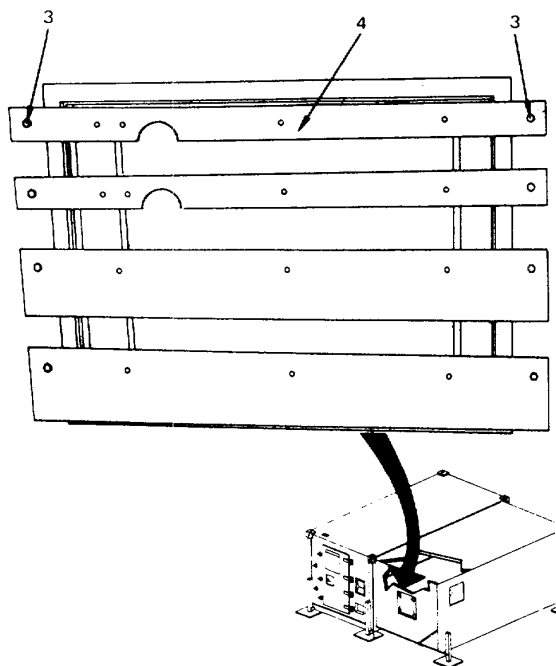

b. Inside shelter, on end wall, remove two bolts (3) securing top bar (4) in place. Remove bar.

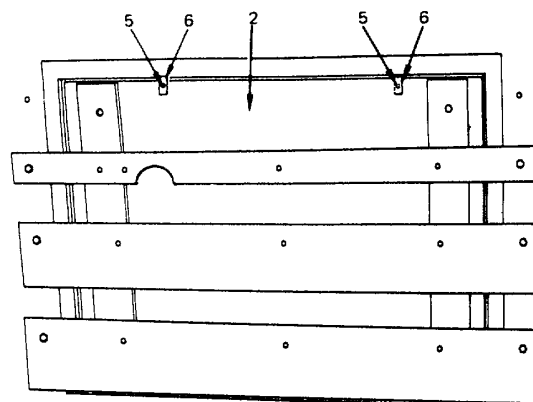

c. Loosen two latch bolts (5). Turn latches (6) clockwise a quarter turn to release fold-down shelf (2).

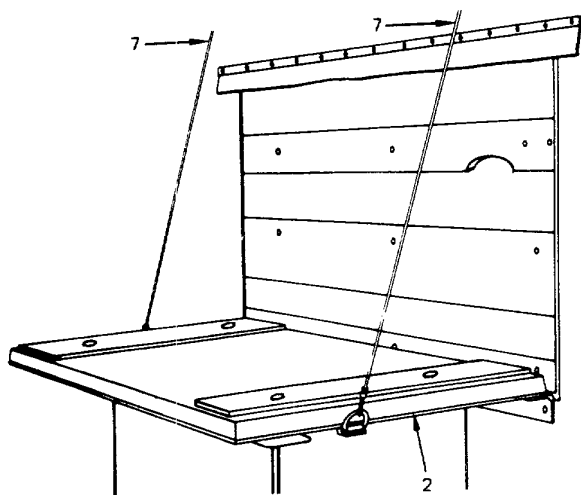

d. Lower shelf (2) to the limit of the support cables (7).

e. Position top bar (4) in old location and install two bolts (3).

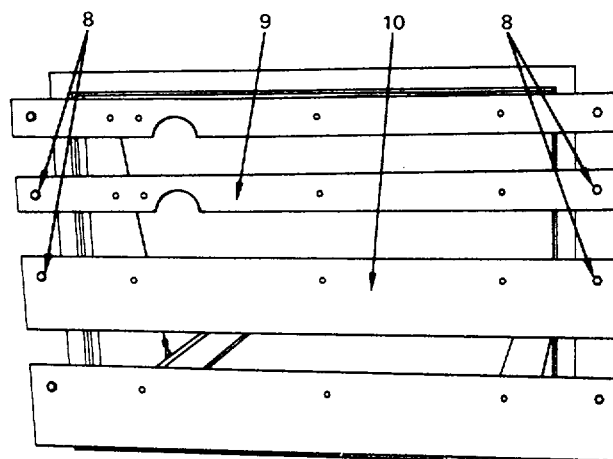
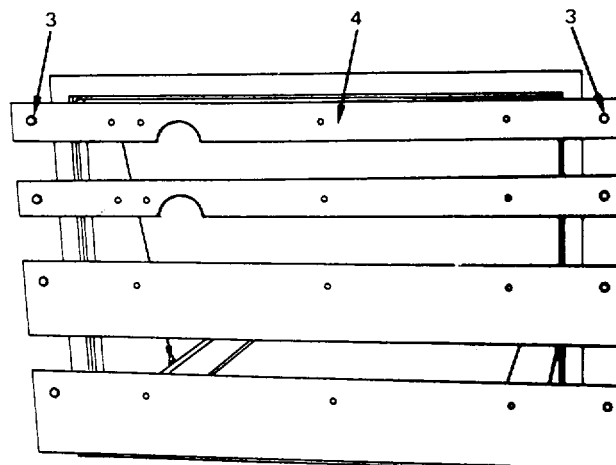

f. Remove four bolts (8) securing bars (9) and (10) in place. Remove both bars.

g. Loosen and turn latches (6) and lower the other ECU shelf (2) as in steps c. and d.

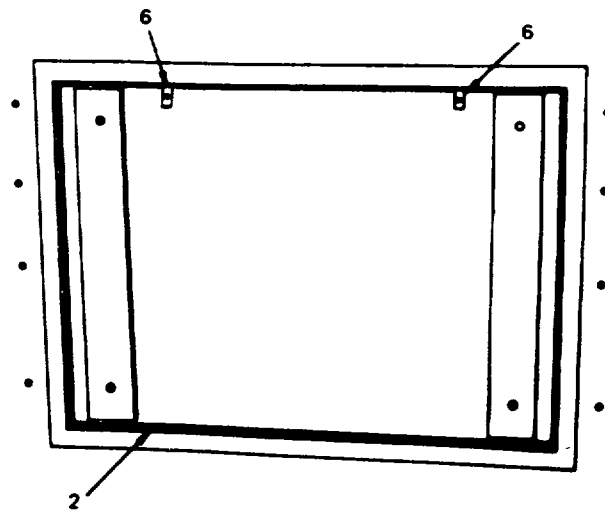

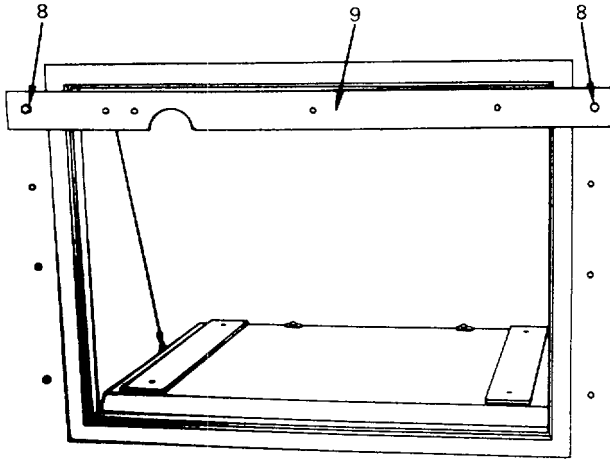

h. Position bar (9) across top of other ECU opening and install bolts (8).

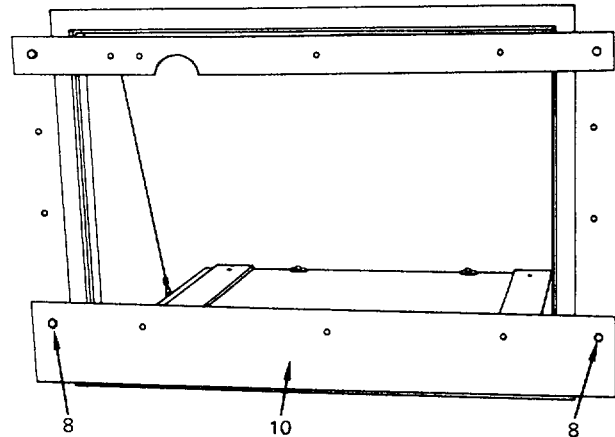

i. Position bar (10) across bottom of other ECU opening and install bolts (8).

2-3. Positioning shop equipment. The following procedures and recommended sequence for moving equipment will be observed. The new positions in which the equipment will be located on the expanded half of the shelter are also identified.

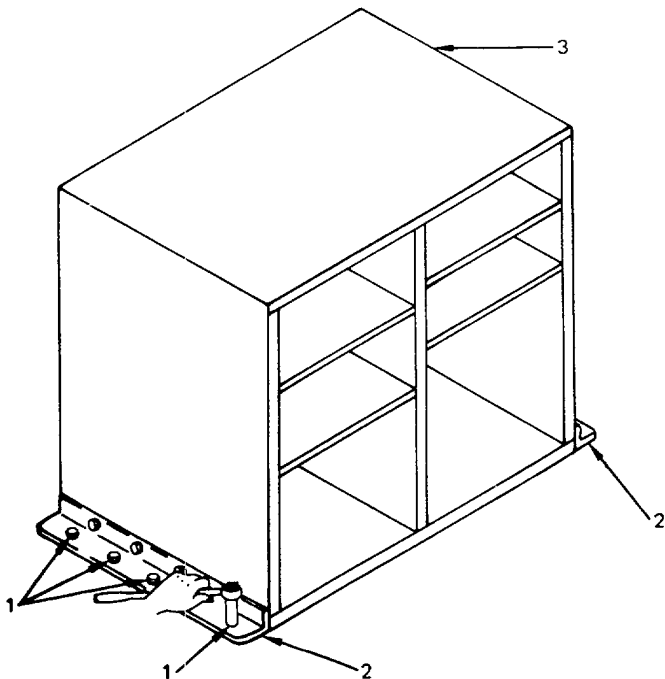

a. Positioning cabinets, bin storage for operation. Procedures for moving both cabinets are identical.

1. Remove five bolts (1) from each of the two brackets (2) located on both sides of the cabinet (3).

2. Position cabinet (3) by sliding along floor to new location.

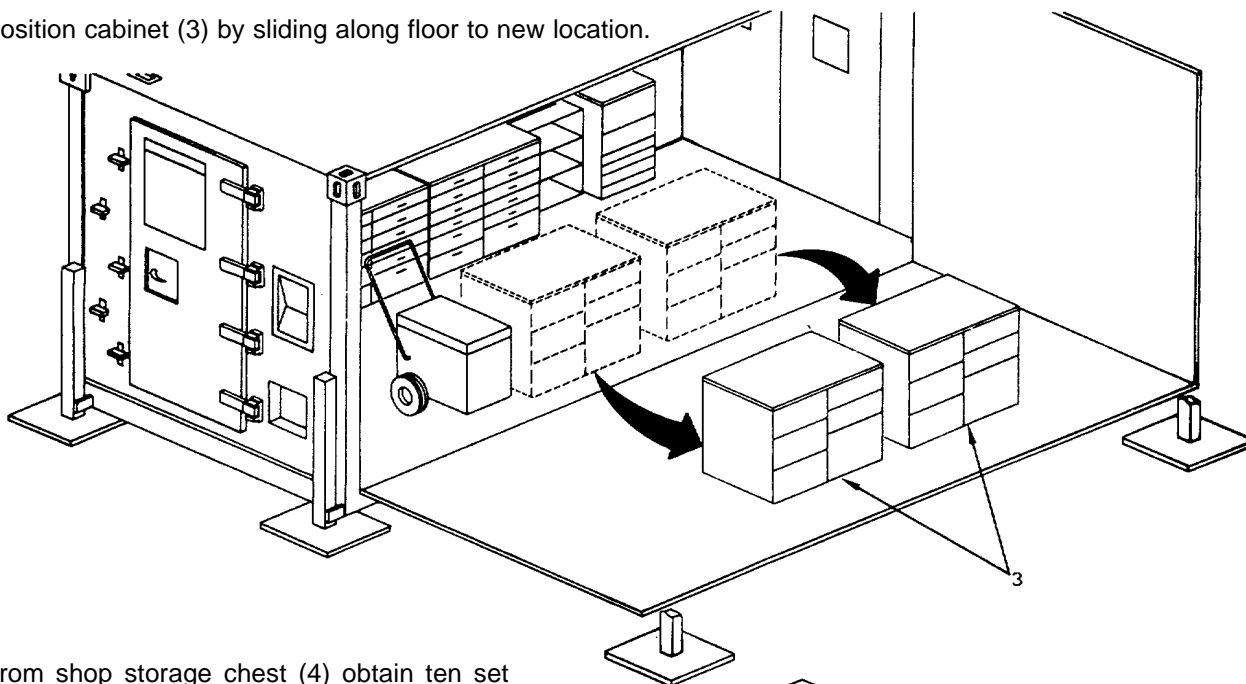

3. From shop storage chest (4) obtain ten set screw floor plugs (5) and insert into empty bolt holes (6).

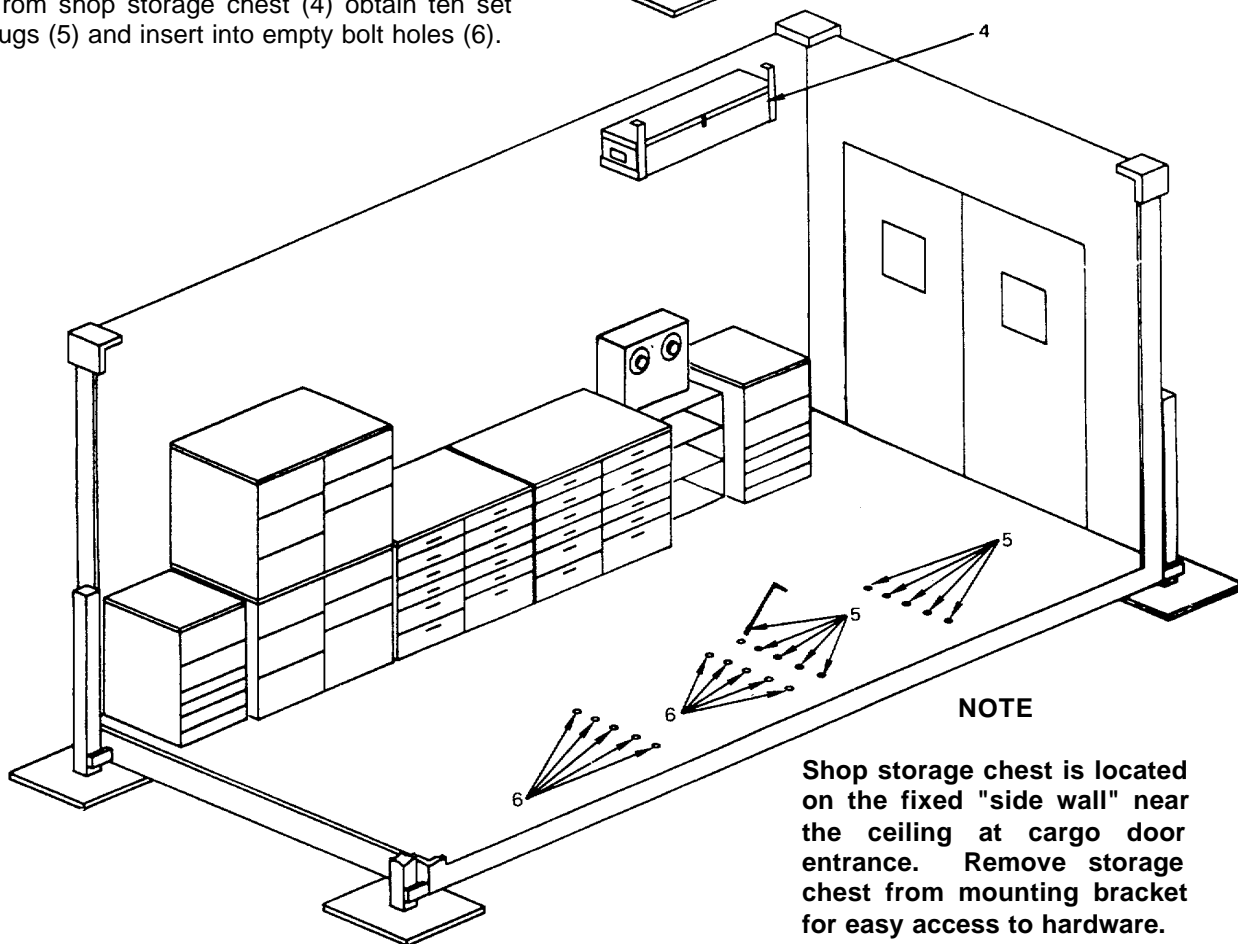

4. Repeat steps 1 thru 3 for second cabinet.

b. Positioning exhaust gas tester for operation.

1. Remove two bolts (1) from tie down bracket (2) and remove bracket (2) from exhaust gas tester (3).

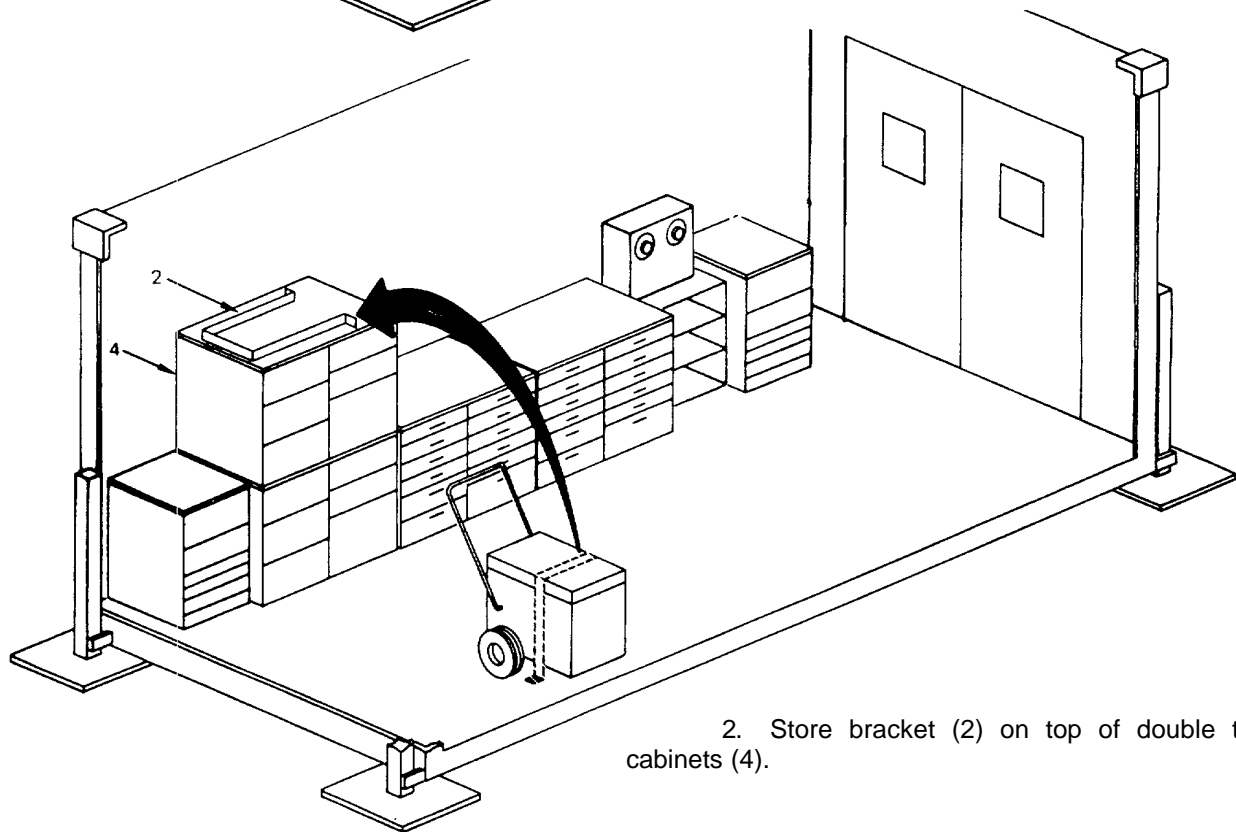
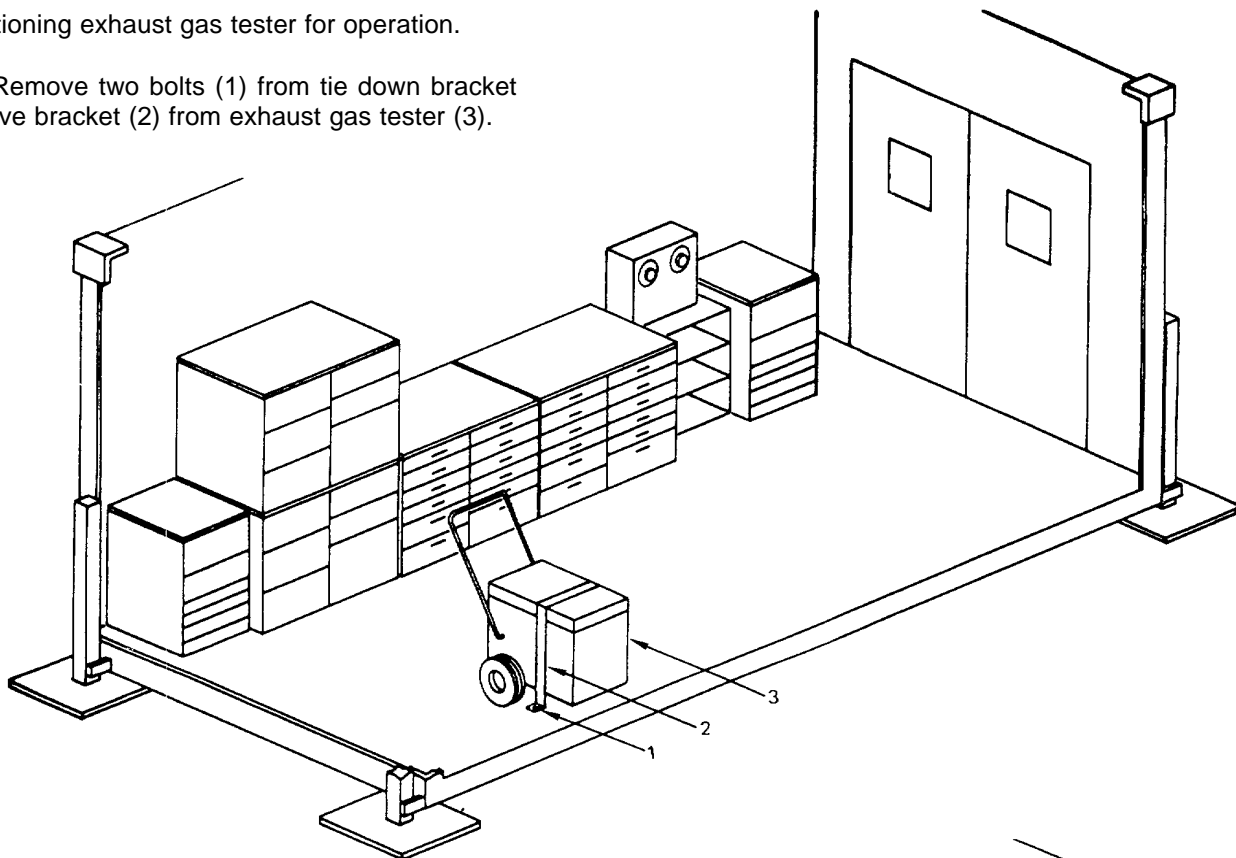

2. Store bracket (2) on top of double tiered cabinets (4).

3. Position gas tester (3) by rolling along floor to new location.

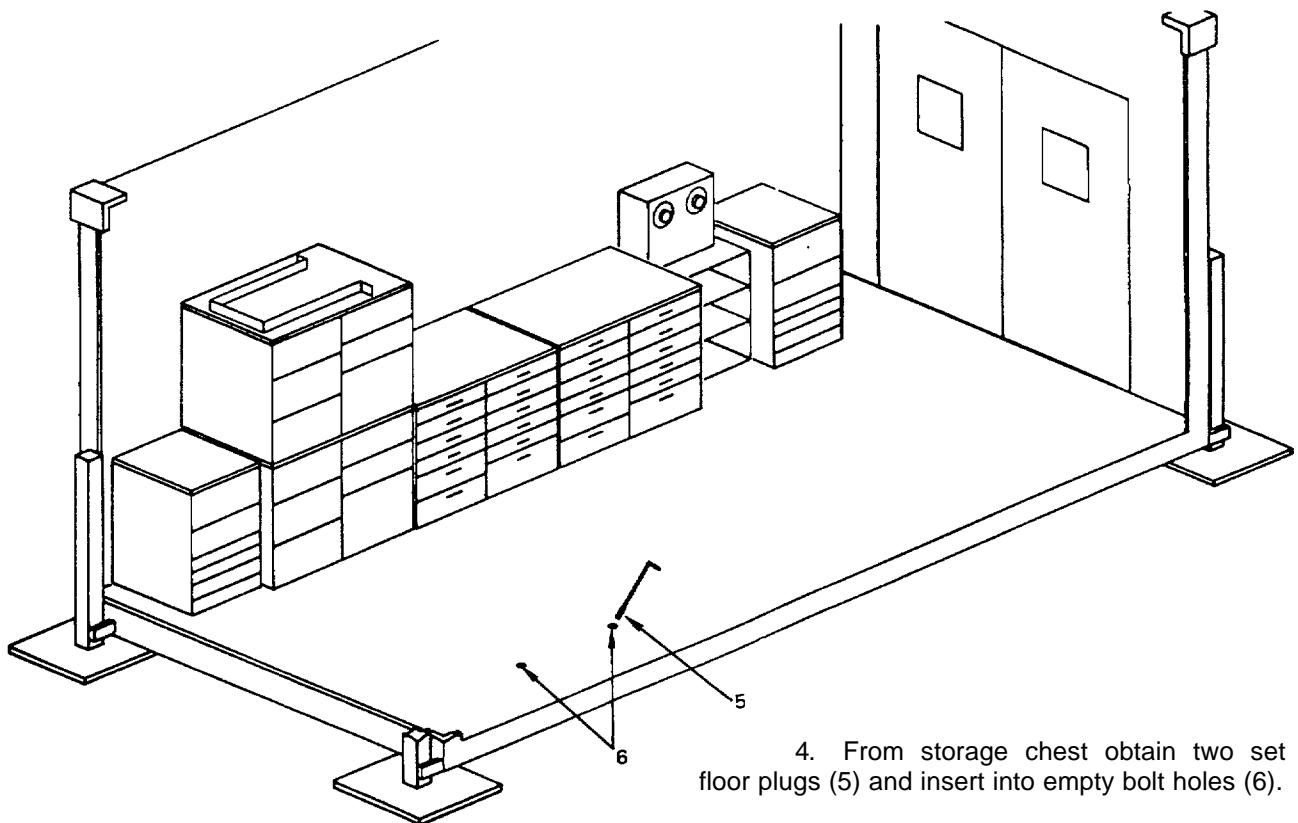
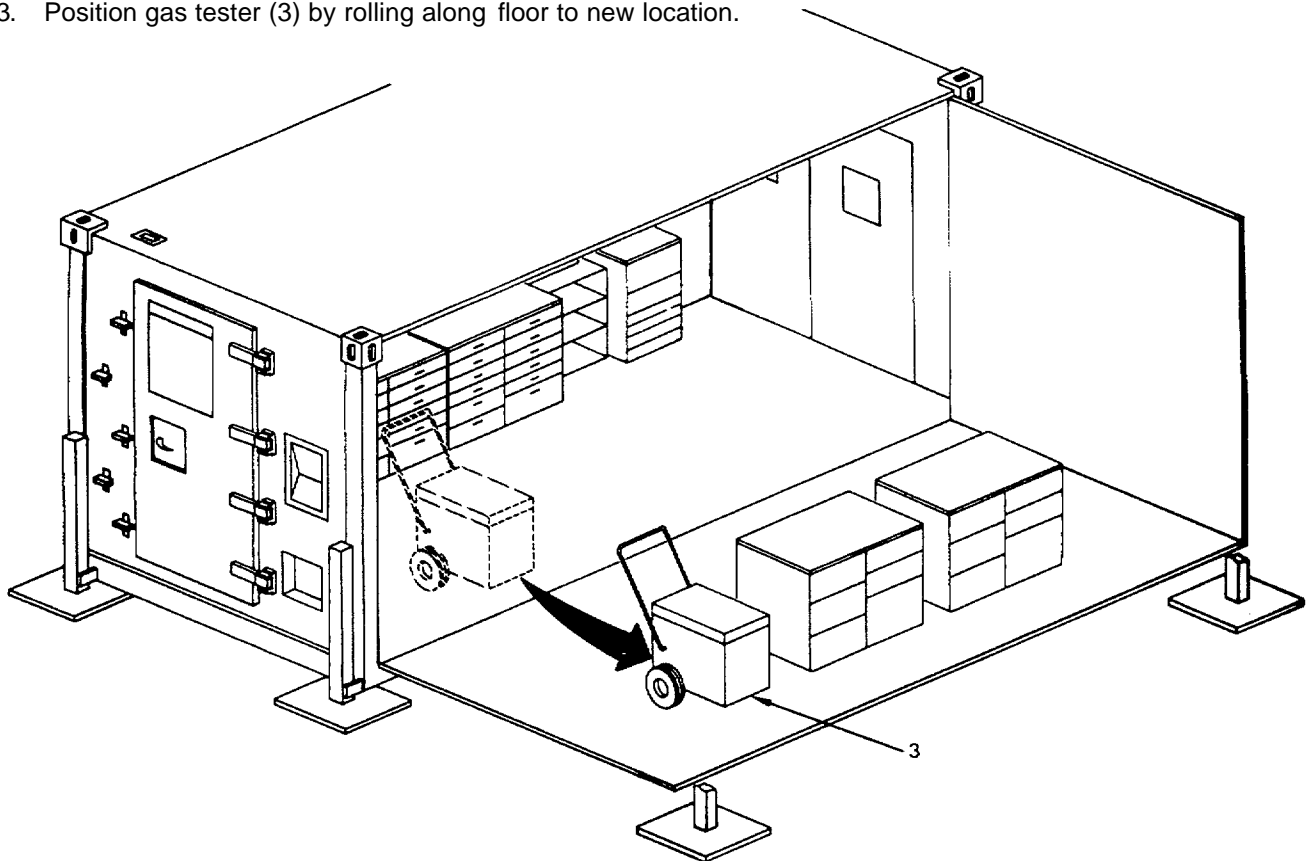

4. From storage chest obtain two set screw floor plugs (5) and insert into empty bolt holes (6).

WARNING

Four people are needed when moving or lifting the Environmental Control Units (ECUs). Each unit weighs approximately 270 pounds. Trying to move or lift an ECU without sufficient help can cause serious injury to personnel.

c. Positioning ECUs for operation.

1. Loosen cargo straps (1) on ECUs (2) and (3), unhook from ring bolts (4) and remove.

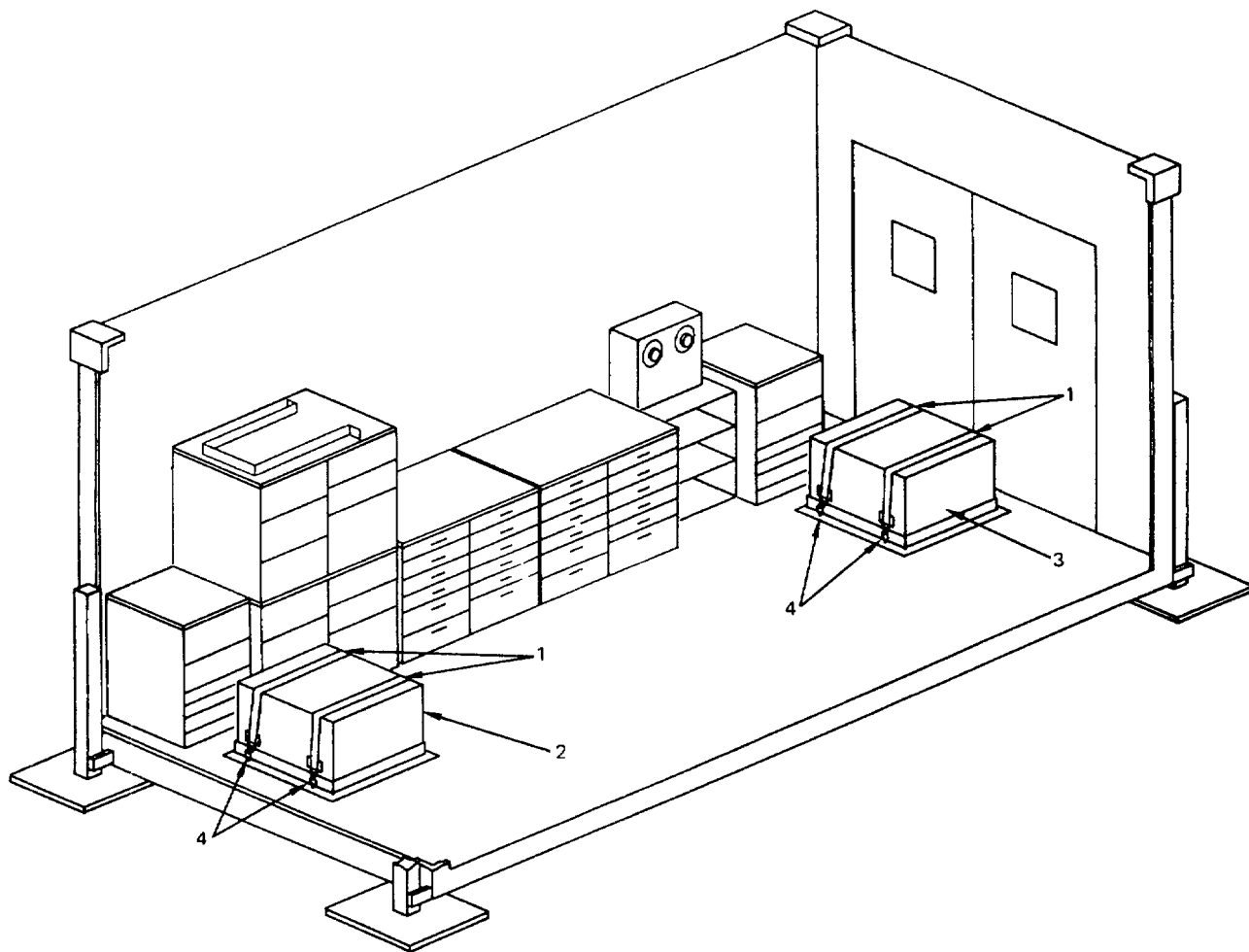

2. Use lift handles (5) to raise ECU (2), from the support frame (6); carry outside and position near "end wall" shelf (7).

3. (For shelter P/N 136-0000-101) Raise ECU (3) from frame (6); carry outside and position near side wall shelf (8). (For shelter P/N 5-4-2828-1). Raise ECU (3) from frame (6); carry outside and position near end wall shelf (8A).

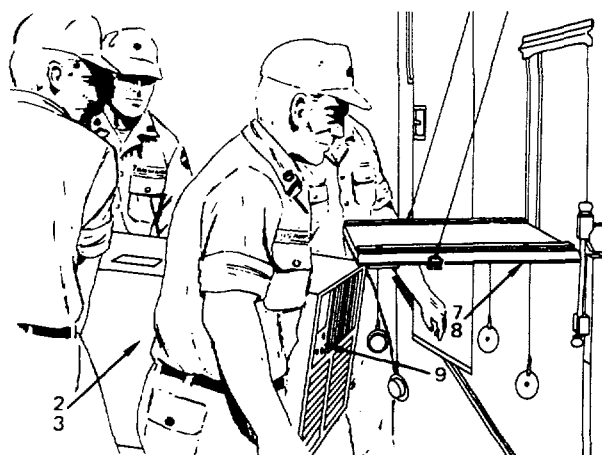
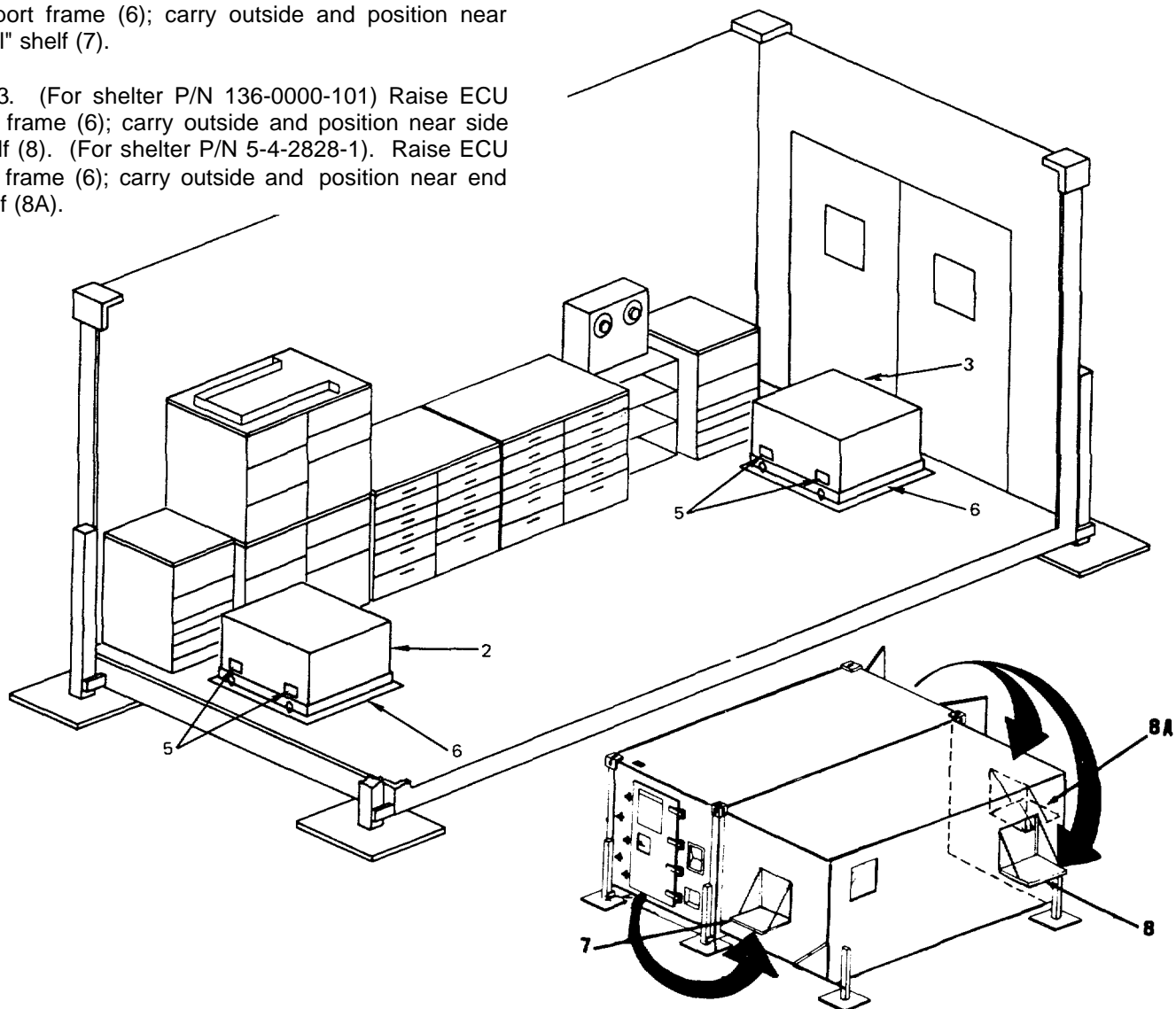

4. Lift ECUs (2) and (3) onto fold-down shelves (7) and (8) with control panel (9) facing toward inside of shop.

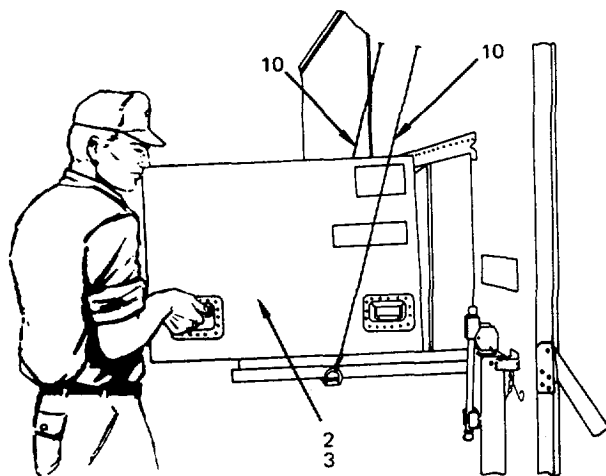

5. Slide ECUs (2) and (3) forward between support cables (10).

6. Aline bolt holes (11) in base of ECU with holes (12) in shelves (7) and (8).

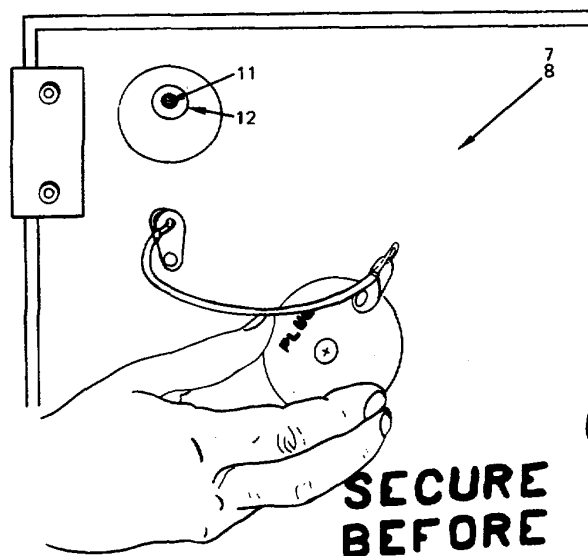

7. Mounting hardware is supplied with each ECU. Install IAW TM 5-4120-369-14.

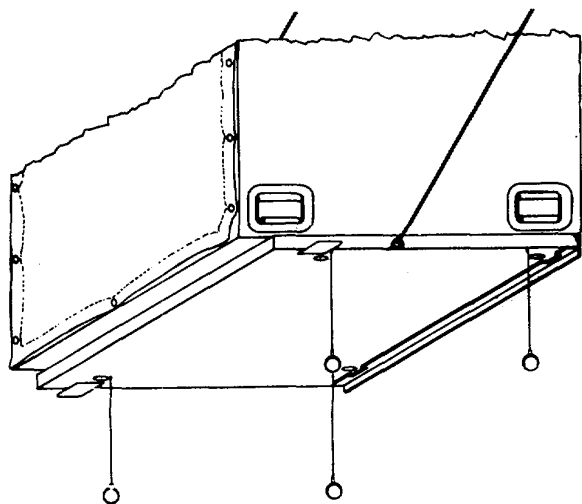

d. Storing ECU support frames.

1. Remove four ring bolts (1) from both ECU support frames (2). Move frames to expanded side wall.

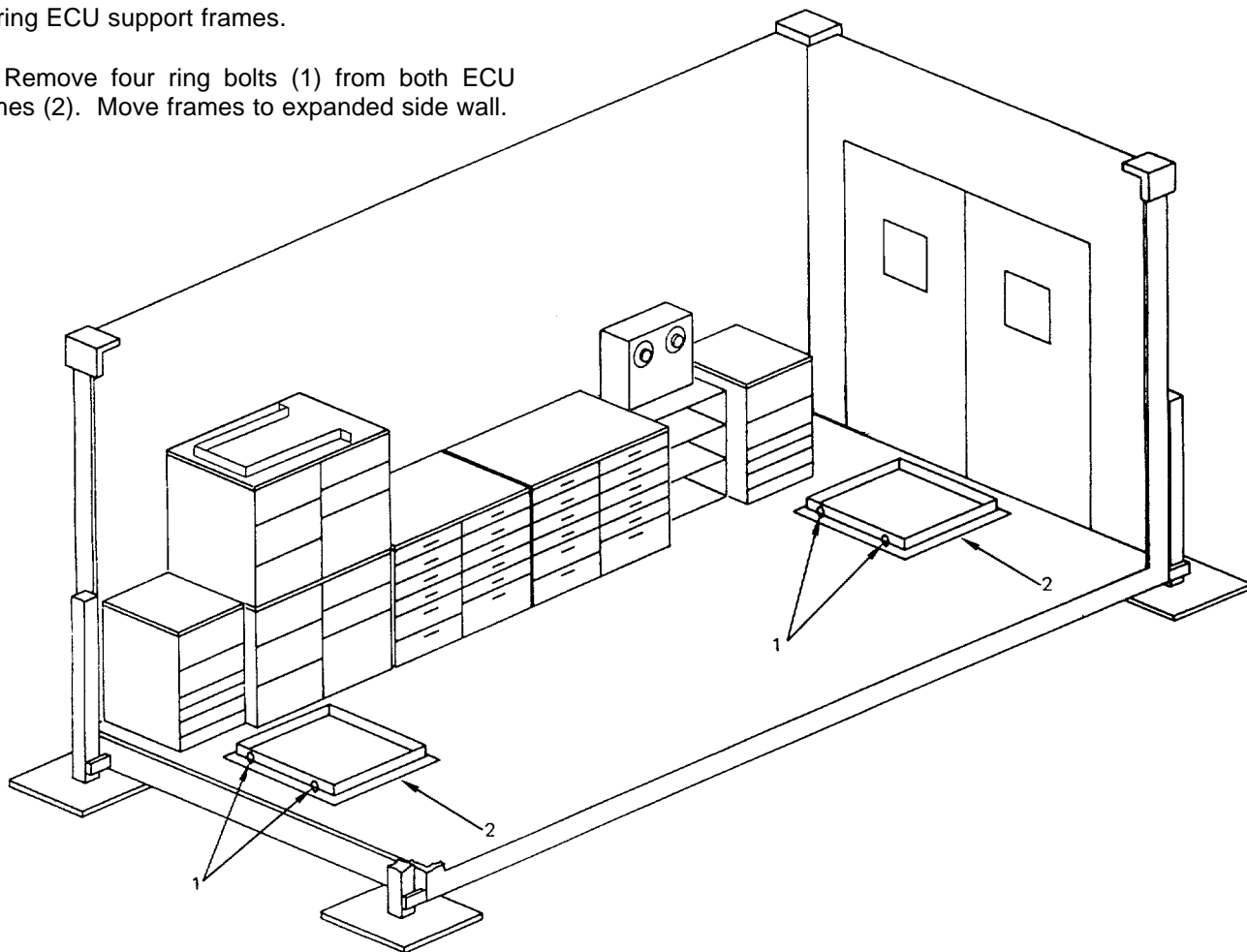

2. Position frames (2) against wall, align holes in frames with wall inserts and secure each frame with four ring bolts (1).

3. Hook cargo straps (3) to ring bolts (1). Tighten and secure.

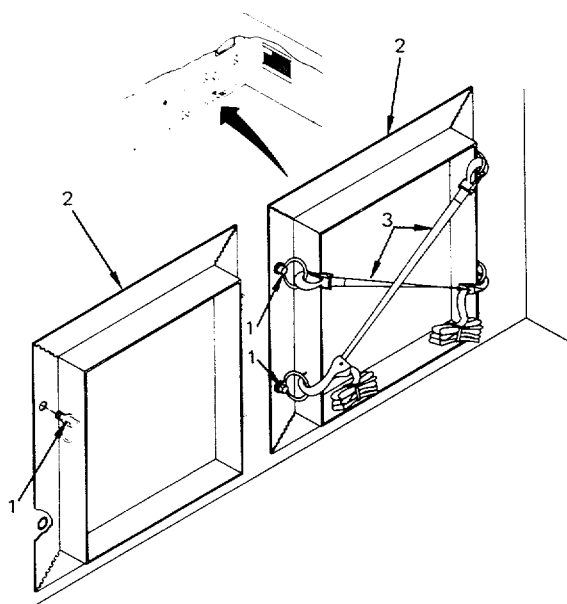

4. From shop storage chest obtain eight set screw floor plugs (4) and insert into empty ring bolt holes (5).

5. Repeat step 4 with floor insert holes of second frame.

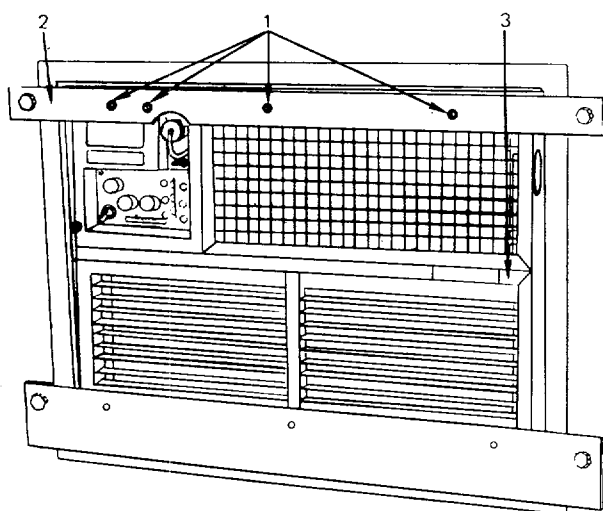
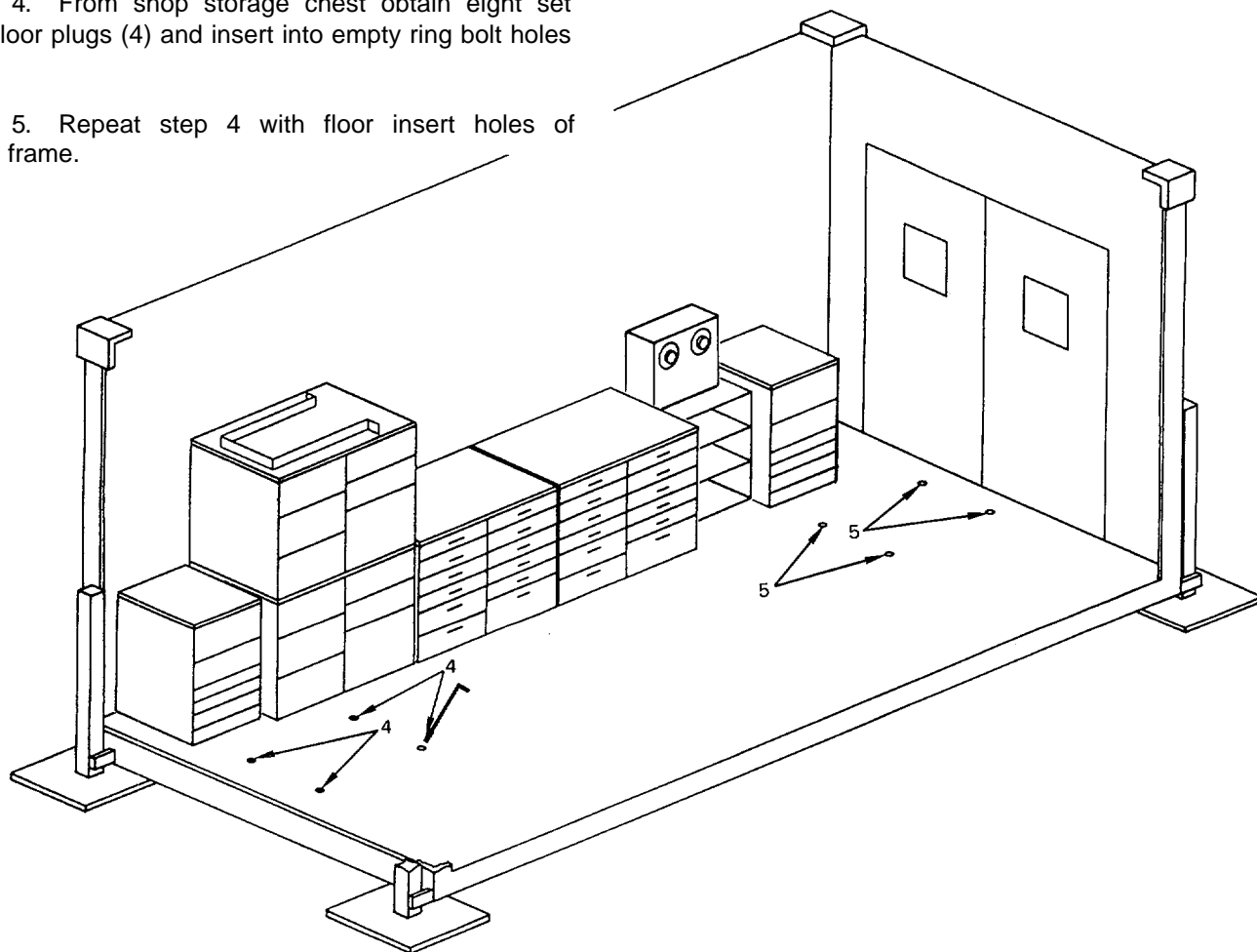

e. Attaching security bars to ECUs.

1. Before installing ECUs, remove seven screws from face of each ECU and store in storage chest.

NOTE

Standard screws will be reinstalled whenever an ECU is to be evacuated for repair or replacement. Special retainer screws will be used to attach security bars to ECUs.

2. From shop storage chest remove fourteen special retainer screws.

3. Install four special retainer screws (1) thru top bar (2) into face of ECU (3) and tighten.

4. Install three special retainer screws (4) thru bottom bar (5) into face of ECU (3) and tighten.
5. Repeat steps 1 thru 4 with other ECU.

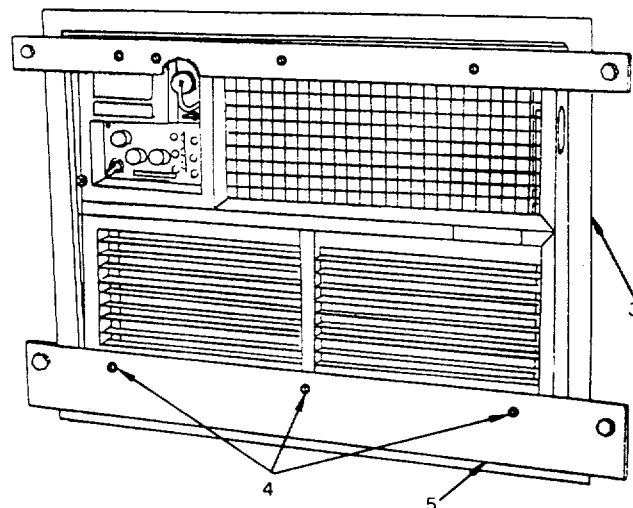

2-4. Safeguarding bolts and washers.

CAUTION

Care must be taken to ensure that the proper bolts and washers are available to secure equipment when shop is to be transported. Lack of correct hardware could cause extensive damage to equipment or the shelter when the shop is moved.

All bolts and washers removed from equipment will be collected and placed in cotton mailing bags (see item 2, App D). Bags are kept in the shop storage chest for safekeeping until shelter is to be moved and equipment rebolted to the floor.

2-5. Electric power.

WARNING

HIGH VOLTAGE exists in the electrical system of the shop. All electrical inspections, repairs or replacement will be performed with the power off and only by qualified electricians. Serious shock hazards exist which could result in injury or even death to personnel.

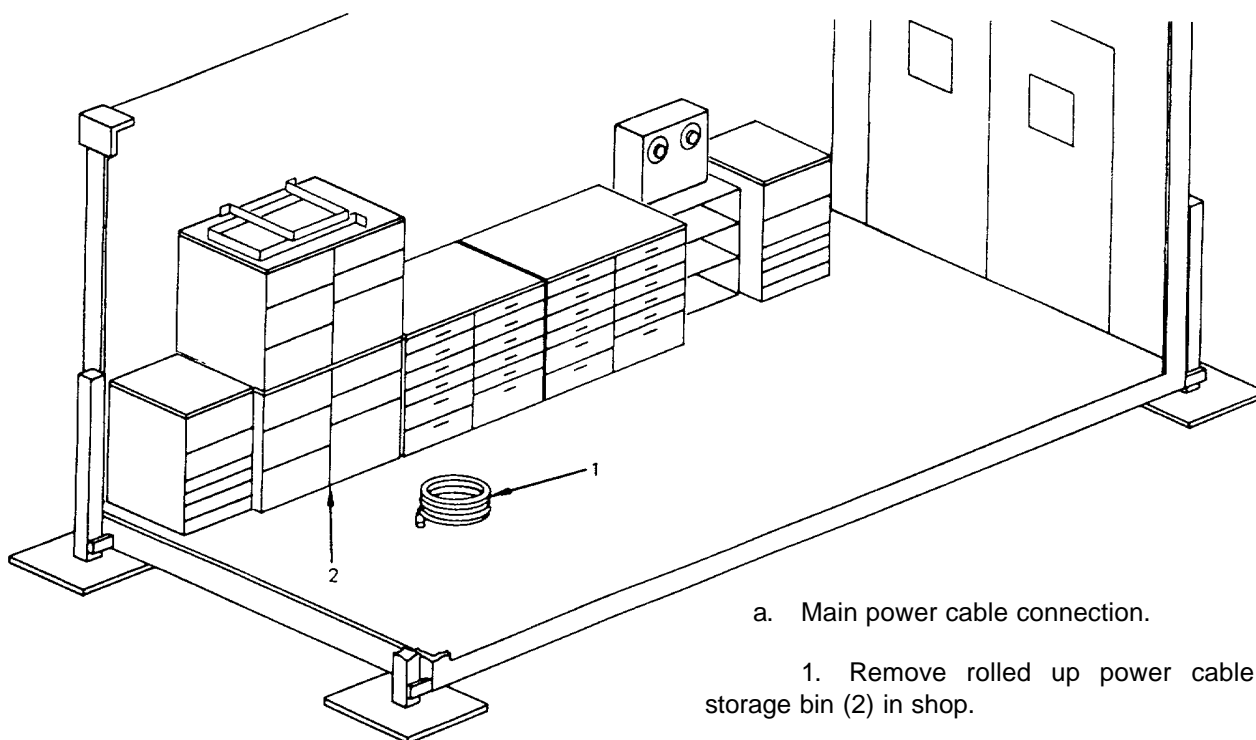

a. Main power cable connection.

1. Remove rolled up power cable (1) from storage bin (2) in shop.

CAUTION

Ensure that the power cable is not twisted, kinked or laid over sharp rocks or projections. Where possible cable should not be routed through any deep ground depressions where water may accumulate.

2. Unroll power cable (1) and extend it between shop (3) and power distribution panel (4).

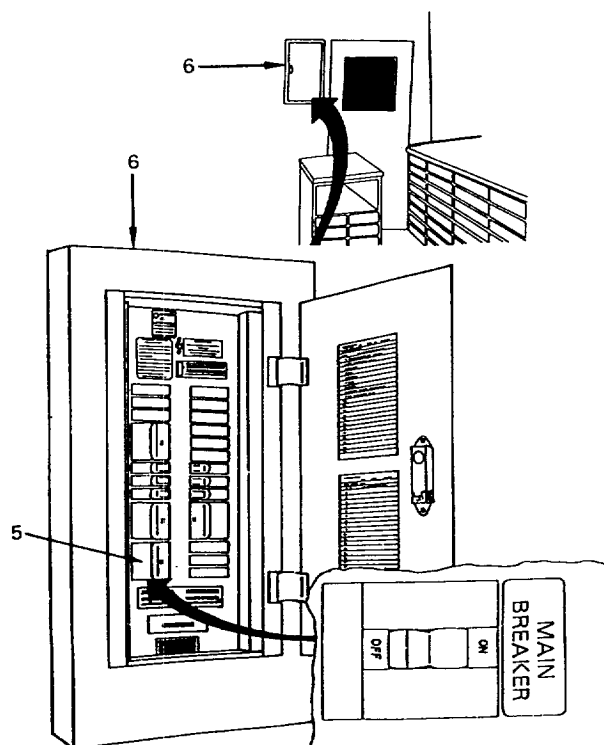
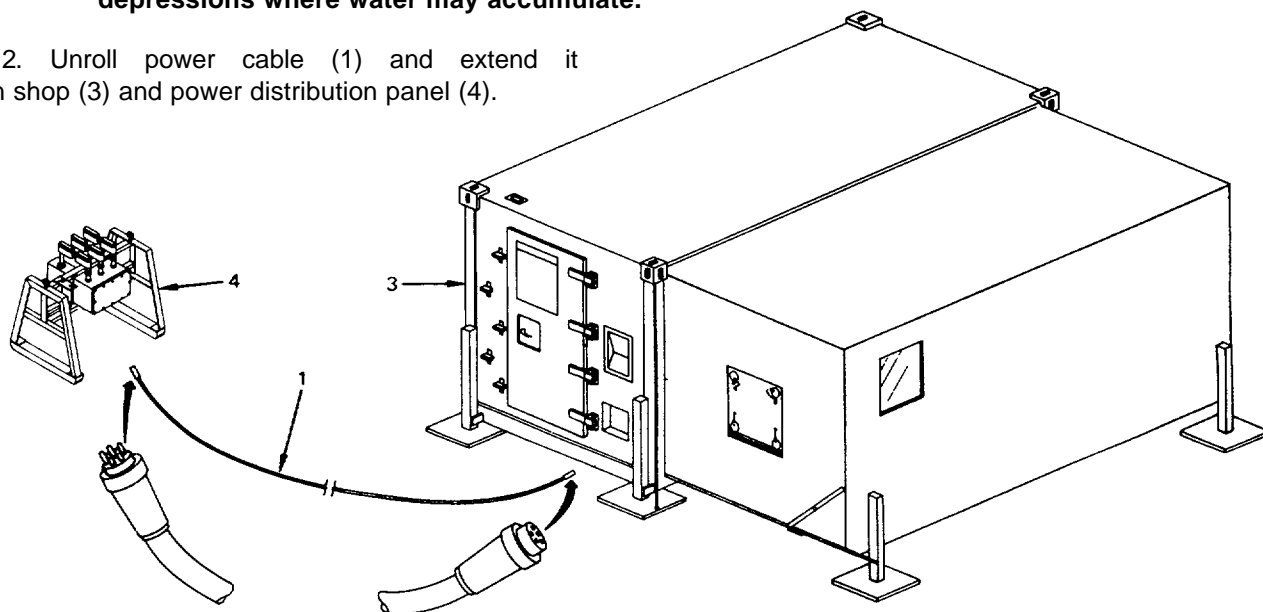

3. Before connecting power cable ensure main circuit breaker (5) in beaker panel (6) is in OFF position.

4. Remove dust cap (7) from "P1" receptacle at power entry (8); insert female power plug (9) and secure with lock ring (10).

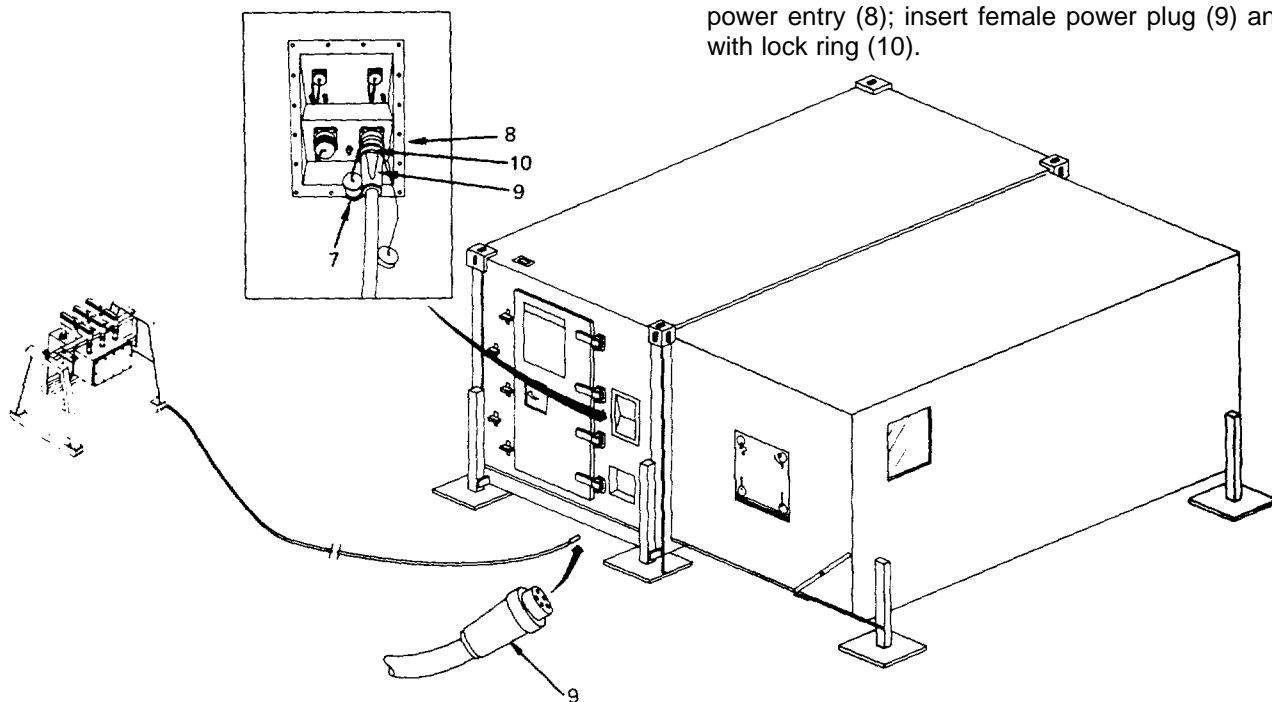

b. Connecting power to ECU.

1. Inspect installation of ECU (1) and power cable (2).
2. Position ECU MODE SELECTOR switch (3) to OFF.
3. Remove cap (4) from receptacle (6).
4. Push end of connector (5) into power input receptacle (6). Push until seated.
5. Screw connector lock ring (7) on receptacle (6).
6. Repeat steps 1 thru 5 with other ECU.

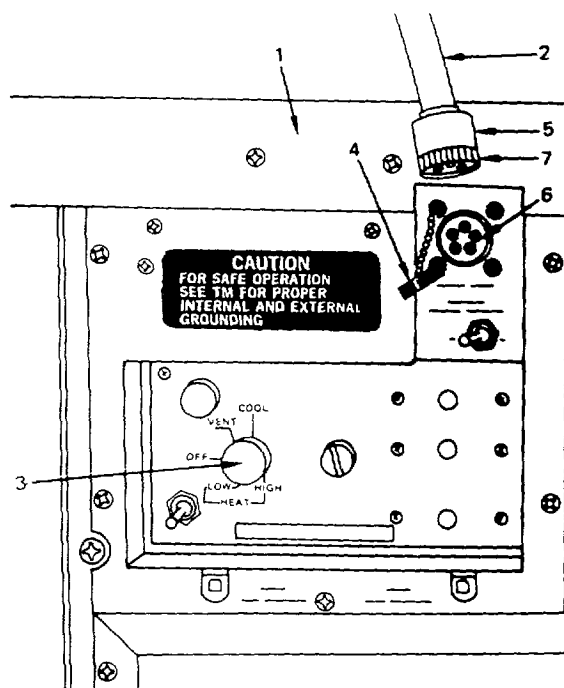

c. Connecting power distribution to panel to generator.

1. Ensure all circuit breakers on the power distribution panel are in the off position.

2. Ensure pigtail is connected to the power distribution panel.

3. A qualified electrician will connect black wire from pigtail to lug L1 on generator, red wire to L2, green wire to L3, and white wire to LO.

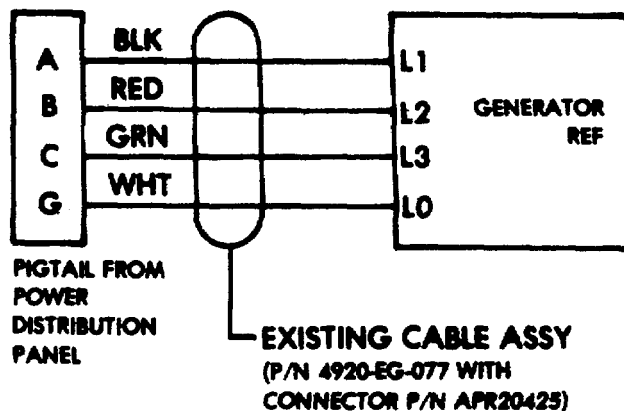

d. External grounding of shop.

1. Remove ground rod assembly from storage chest.

2. Install external ground IAW TM 10-5411-201-14.

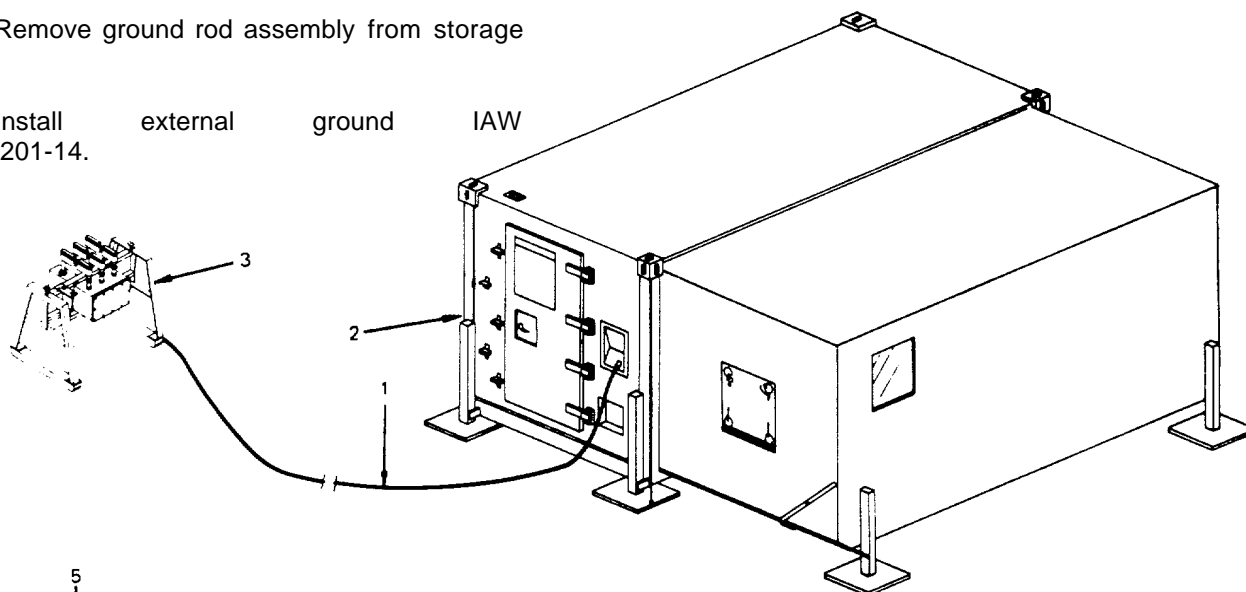

e. Power on to shop.

1. A qualified electrician will make connection of main power cable (1) from shop (2) at power distribution panel (3).

2. Shop personnel will move the main circuit breaker (4) in the circuit breaker panel (5) from OFF to ON.

3. See that all other circuit breakers are in the ON position.

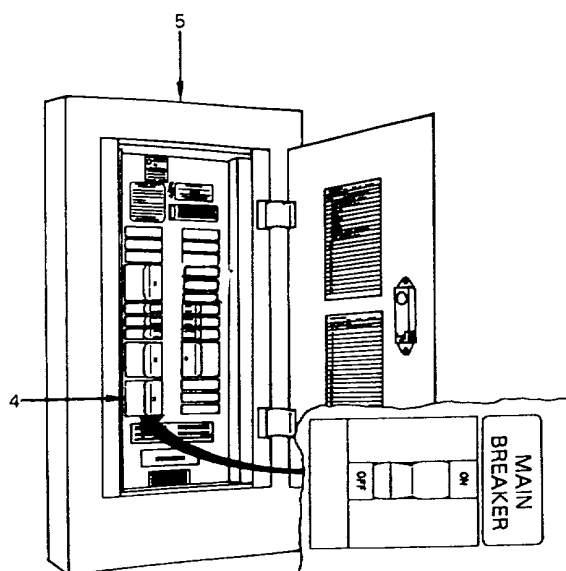

2-6. Other shop utilities.

In addition to electrical power the shop is provided with connections for compressed air and water.

a. Compressed air connection.

1. Remove protective dust cap (1) from air inlet nipple (2) at the service utility panel (3). Store in shop storage chest.

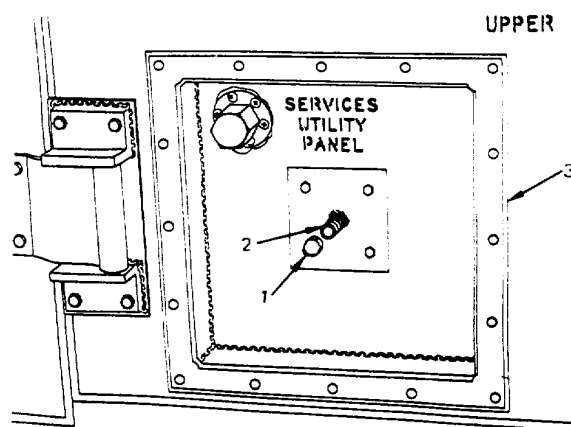

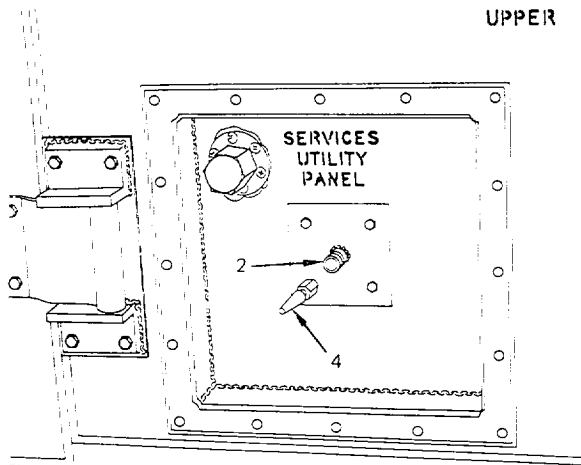

2. From storage chest remove a quick disconnect coupling (4).
3. Install the quick disconnect coupling (4) on air inlet nipple (2).
4. Tighten coupling (4) securely.

b. Water supply connection.

NOTE

When water is to be supplied to shelter proceed as follows.

1. Remove protective dust cap (1) from each end of water feed thru connector (2).
2. Install adapters and fittings as required.

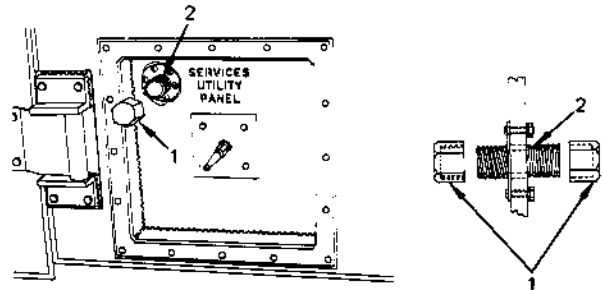

NOTE

Reposition storage chest in mounting bracket when no longer required.

2-7. Checking shelter level. Once all equipment is in the recommended operational position recheck leveling of shelter. Use procedures in TM 10-5411-201-14 to verify and adjust level. Correct adjustment is essential to ensure proper operation of machine tools, doors and access panels.

The Electric/Instrument Shop is now operational.

SECTION III. PREPARATION FOR SHIPMENT

2-8. Striking the shelter. Shop utilities (other than electrical).

a. Disconnecting water supply. (When installed)

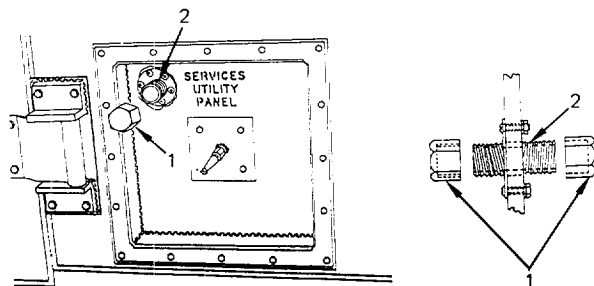

1. Obtain two protective dust caps (1) from shop storage chest.

2. Install dust cap on each end of feed thru connector (2), tighten securely.

b. Disconnecting compressed air.

1. Remove quick disconnect coupling (1) from the air inlet nipple (2). Store in shop storage chest.

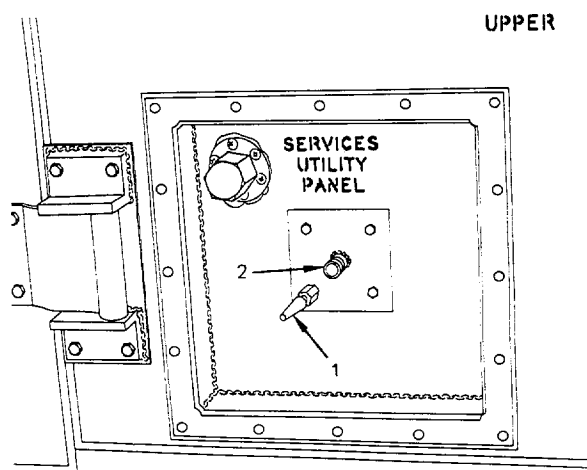

2. Obtain a dust cap (3) from storage chest.

3. Install dust cap (3) on air inlet nipple (2), tighten securely.

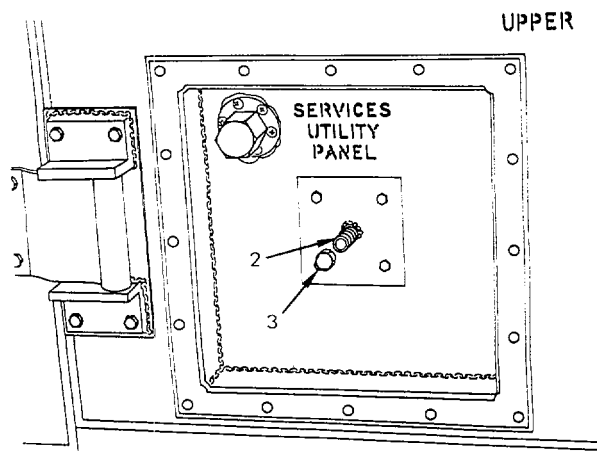

2-9. Power shutdown.

a. See that all electrical tools and shop equipment have been turned OFF.

b. Circuit breaker panel. Move main circuit breaker (1) in the circuit breaker panel (2) from ON to OFF.

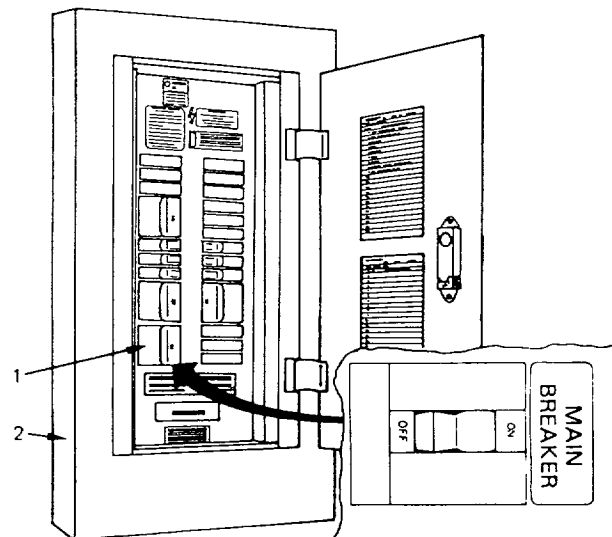
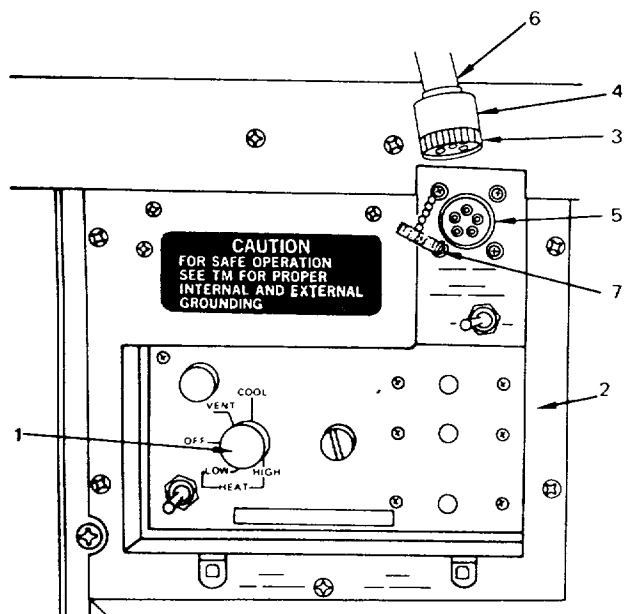

c. Disconnecting ECUs.

1. Place MODE SELECTOR switch (1) of ECU (2) in OFF position.

2. Unscrew lock ring (3) and pull connector (4) from ECU receptacle (5). Store cable (6) IAW TM 10-5411-201-14.

3. Install cap (7) on receptacle (5).

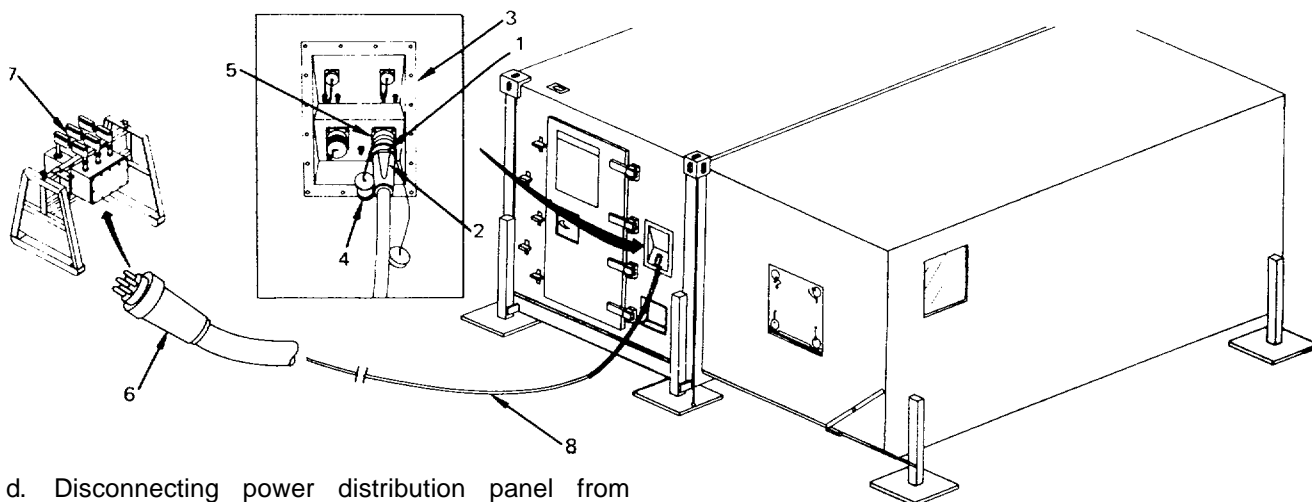

d. Disconnecting power distribution panel from generator.

1. Ensure all circuit breakers on the power distribution panel are in the off position.

2. Disconnect color coded wires on pigtail from lugs on generator.

e. Disconnecting main power cable.

1. Unscrew lock ring (1), disconnect power cable connector (2) at power entry panel (3).

2. Install dust cap (4) on "P1" receptacle (5).

3. After a qualified electrician has disconnected male end of cable (6) from power distribution panel (7) clean cable (8) with rag and roll.

4. After cable (8) has been cleaned and rolled, store in storage bin (9).

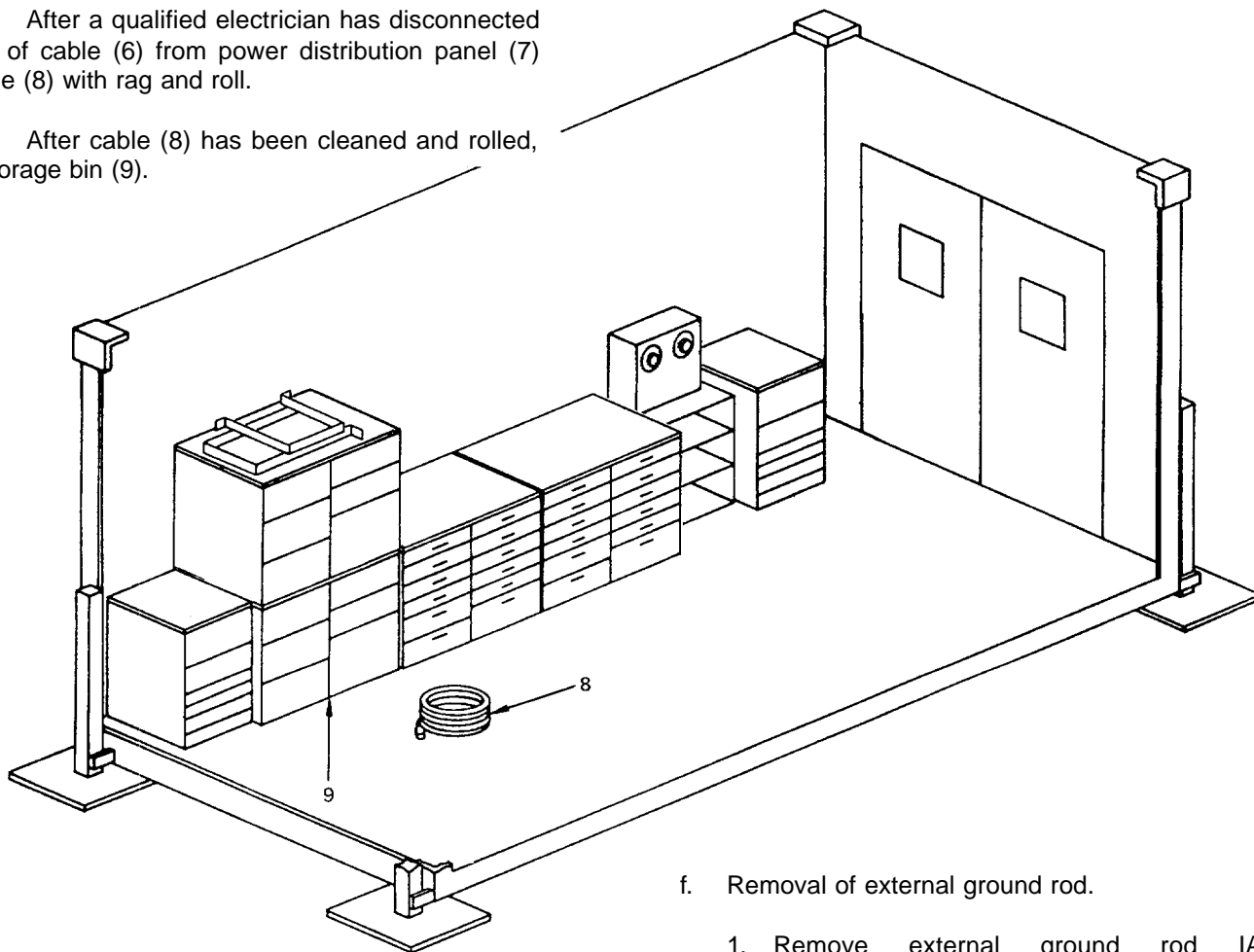

f. Removal of external ground rod.

1. Remove external ground rod IAW TM 10-5411-201-14.

2. Store ground rod assembly in storage chest.

2-10. Bolts and washers for equipment tie down.

CAUTION

Care must be taken to ensure that the proper bolts and washers are used to secure equipment when shop is transported. Lack of correct hardware could cause extensive damage to equipment or the shelter.

- a. Remove cotton bags with tie down bolts and washers from shop storage chest.
- b. Inspect hardware for damage or missing parts.
- c. Check out a torque wrench from tool crib.
- d. All bolts will be tightened to the specific torque value given. See App. F.

CAUTION

Torque values provided must be respected to prevent possible damage to equipment or the shelter. Improper procedures could result in extensive damage to government property.

2-11. Repositioning shop equipment. The following procedures, and recommended sequence, for moving equipment from the operational mode to the transport or storage mode will be observed.

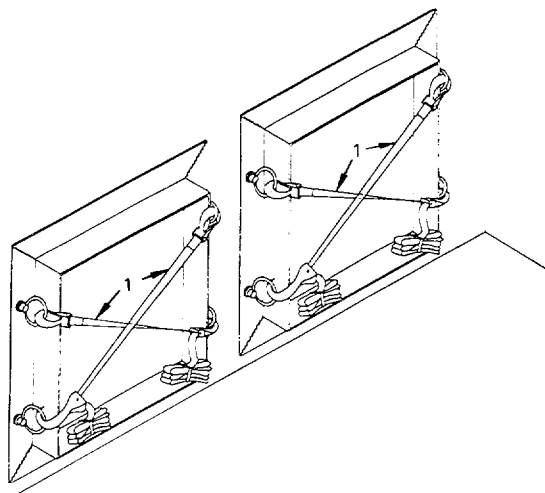

a. Installation of ECU support frames.

1. Loosen and remove cargo straps (1).

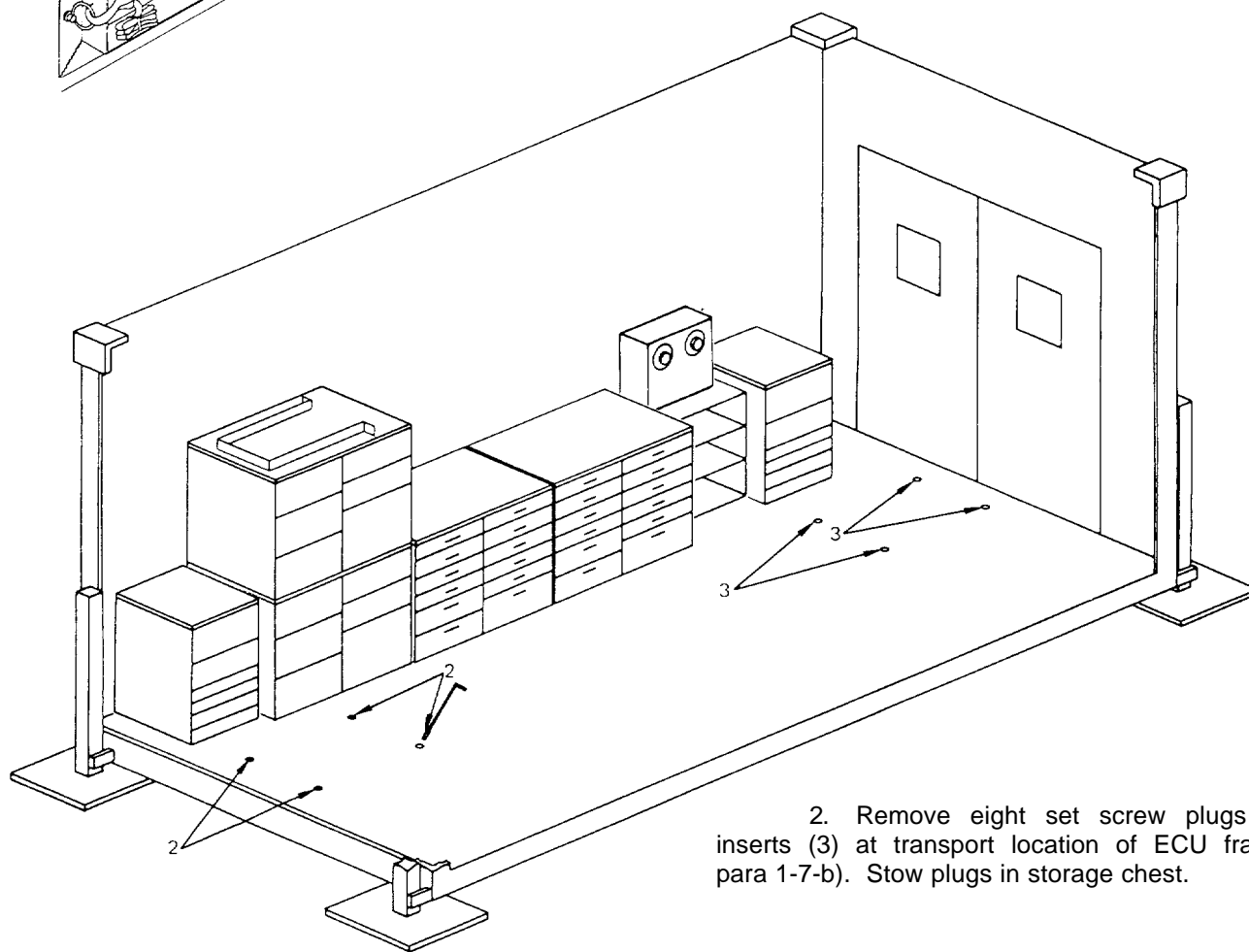

2. Remove eight set screw plugs (2) from inserts (3) at transport location of ECU frames (see para 1-7-b). Stow plugs in storage chest.

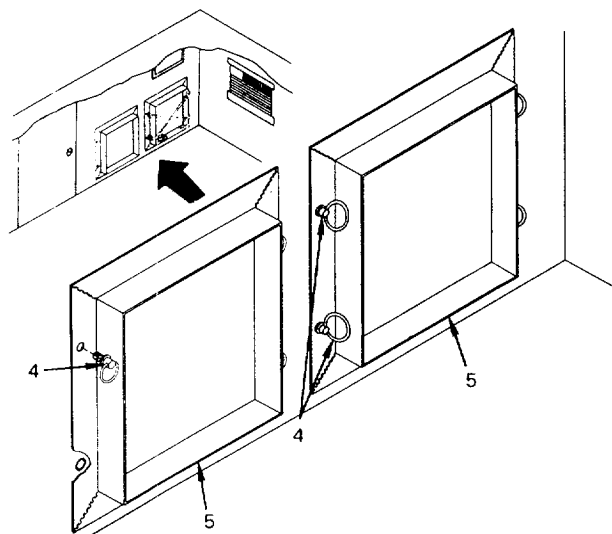

3. Remove eight ring bolts (4) securing frames (5) to wall. Remove frames.

4. Position ECU frames (5) over floor inserts and align holes.

5. Install the eight ring bolts (4) and securely tighten.

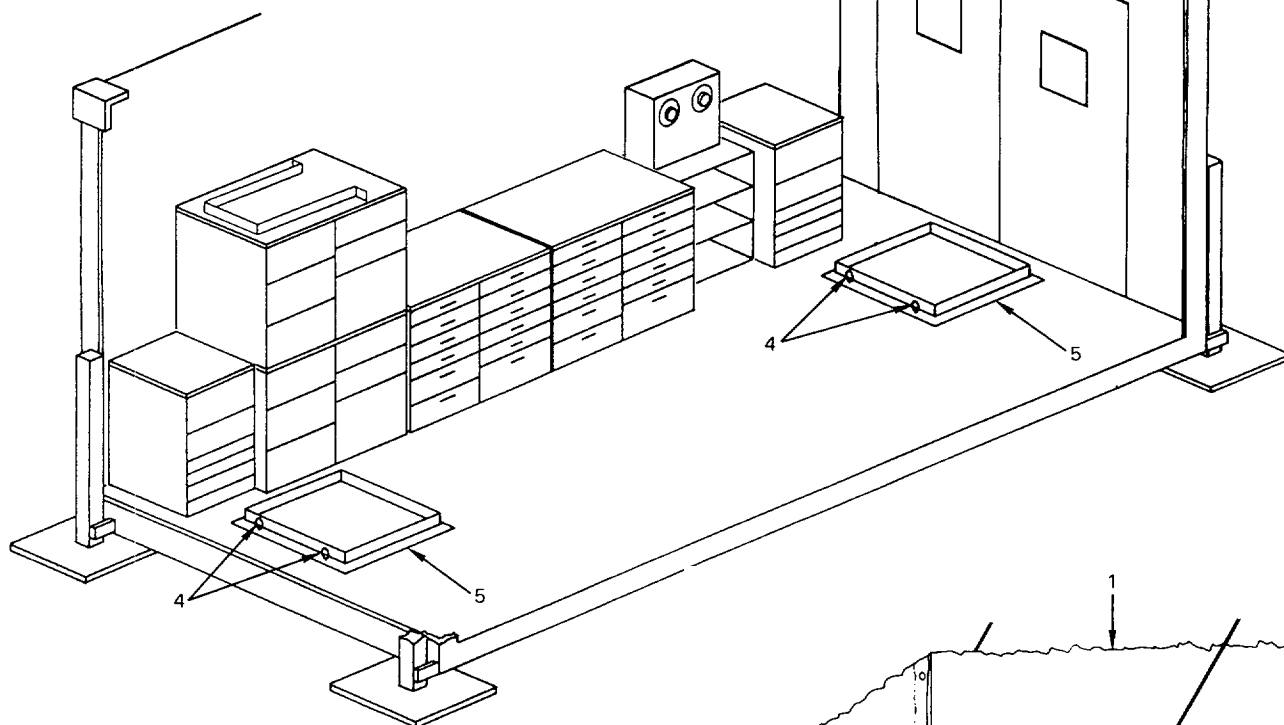

b. Repositioning ECUs for transport.

1. Remove mounting hardware securing ECU (1) to fold-down shelf (2). (See TM 5-4120-369-14)

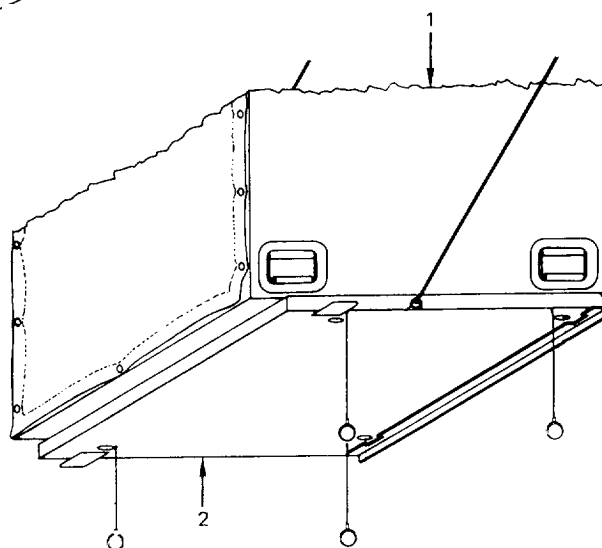

2. Remove four special retainer screws (3) from top bar (4). Remove three special retainer screws (5) from bottom bar (6). Stow screws in storage chest.

3. Repeat steps 1 and 2 with other ECU.

c. Repositioning ECUs in support frames.

WARNING

Four people are needed when moving or lifting the Environmental Control Units (ECUs). Each unit weighs approximately 270 pounds. Trying to move or lift an ECU without sufficient help can cause serious injury to personnel.

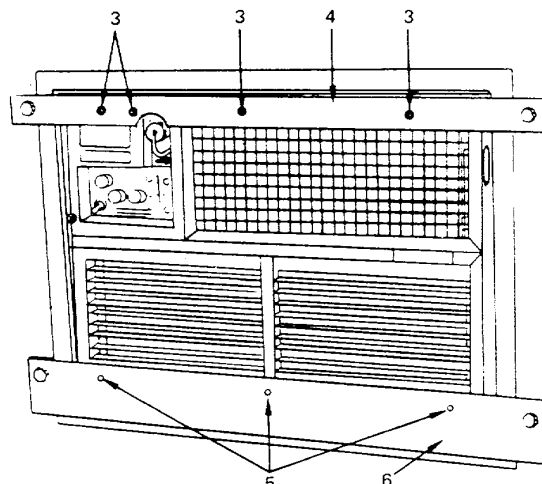

1. Slide ECU (1) off fold-down shelf (2) and carry to personnel door (3). (For shelter P/N 136-0000-101) Slide ECU (4) off fold-down shelf (5) and carry to cargo door (6). (For shelter P/N 5-4-2828-1) Slide ECU (4) off fold-down shelf (5A) and carry to cargo door (6).

2. Using lift handles (7) raise ECU (4) and position in frame (8) just inside cargo door.

3. Using lift handles (7) raise ECU (1) and position in frame (9) just inside personnel door.

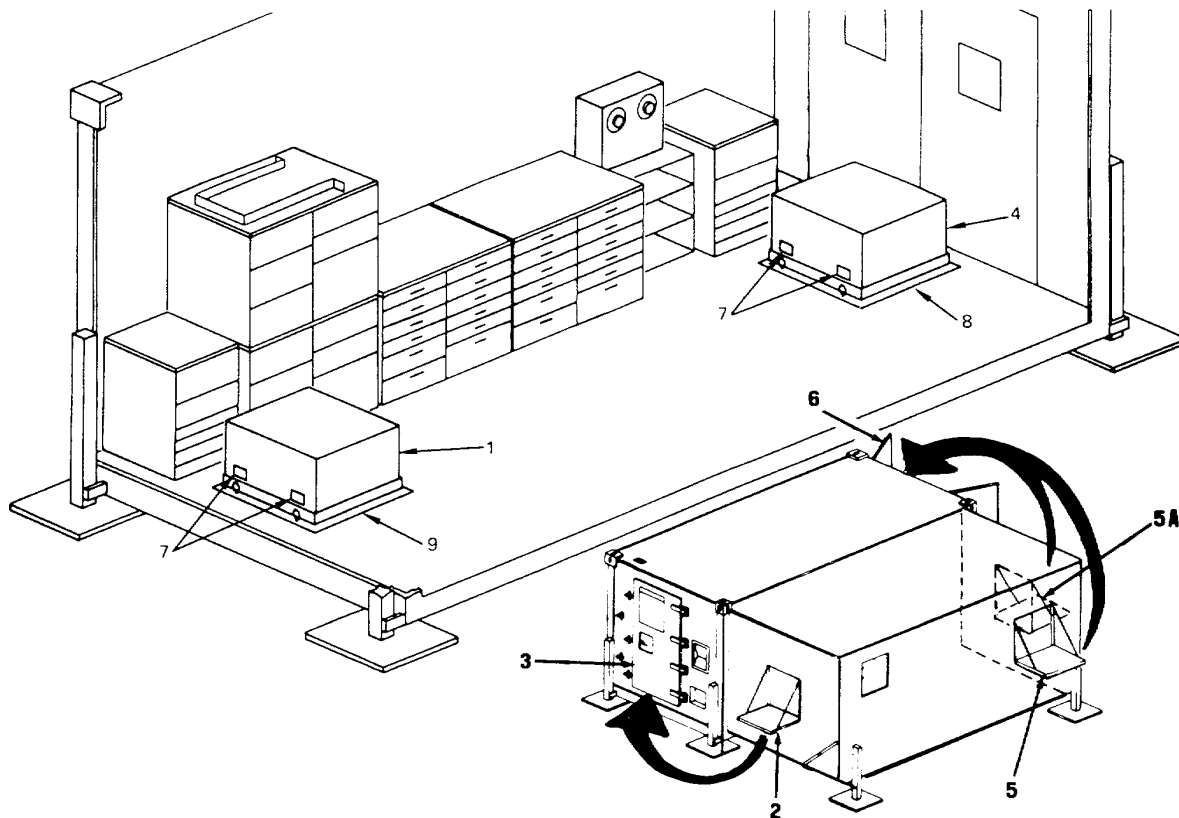

4. Position two cargo straps (10) on each ECU and hook to ring bolts (11). Tighten straps to secure ECUs in place.

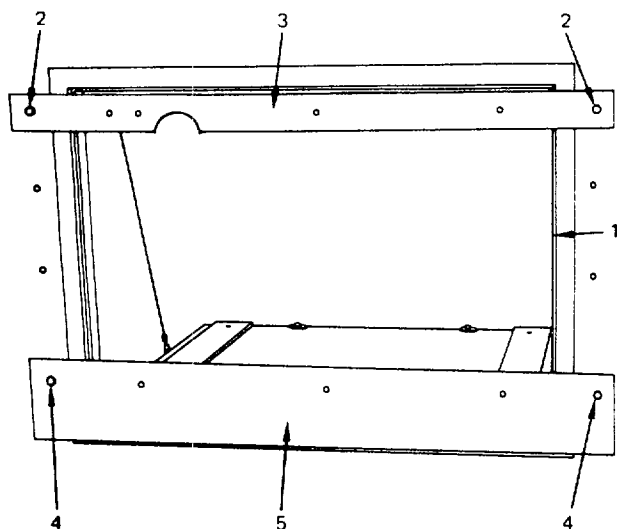
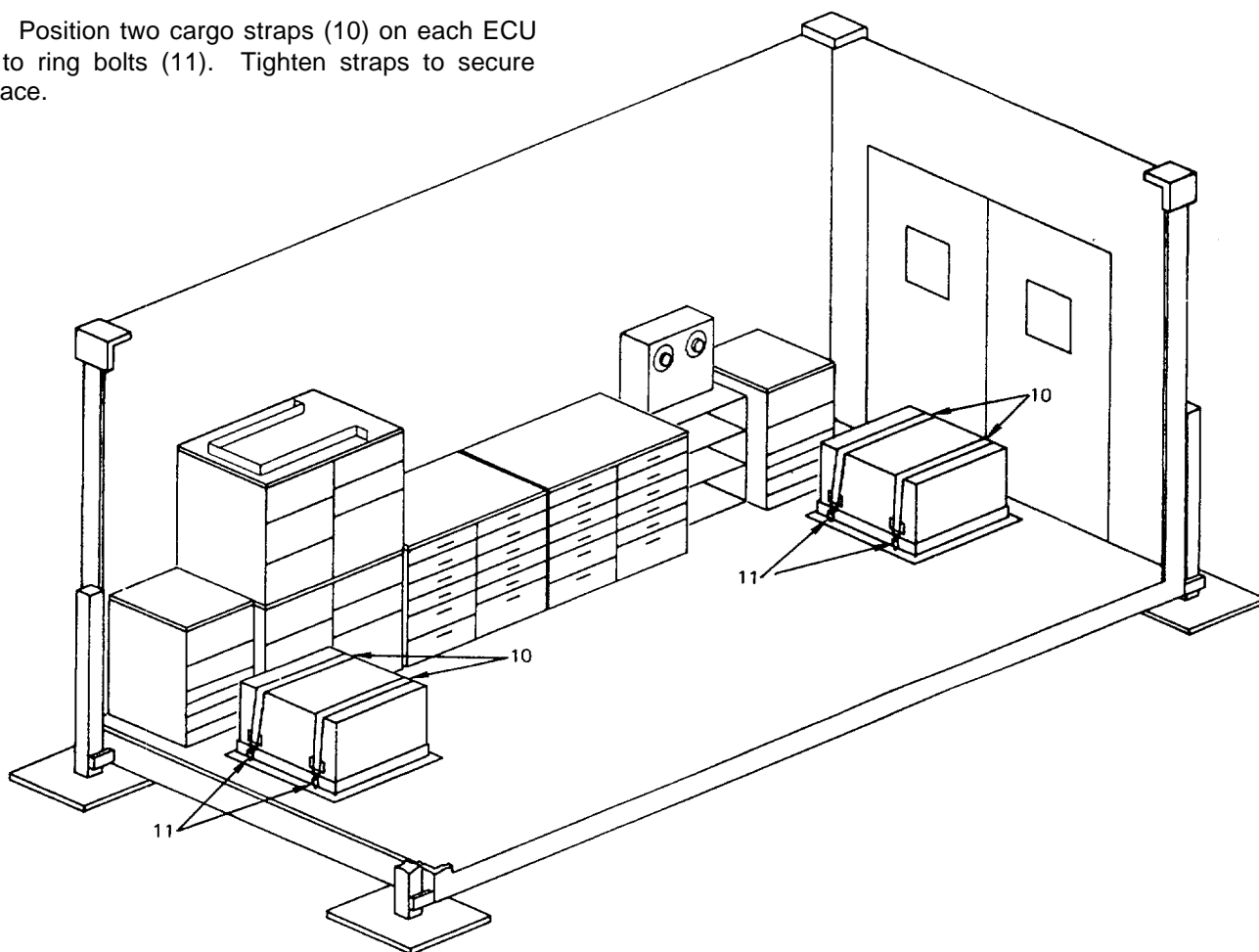

d. Closing ECU shelves.

1. (For shelter P/N 136-0000-101) From side wall ECU opening (1), remove two bolts (2) from top bar (3) and two bolts (4) from bottom bar (5). Remove bars. (For shelter P/N 5-4-2828-1) from end wall ECU opening (1), remove two bolts (2) from top bar (3) and two bolts (4) from bottom bar (5). Remove bars.

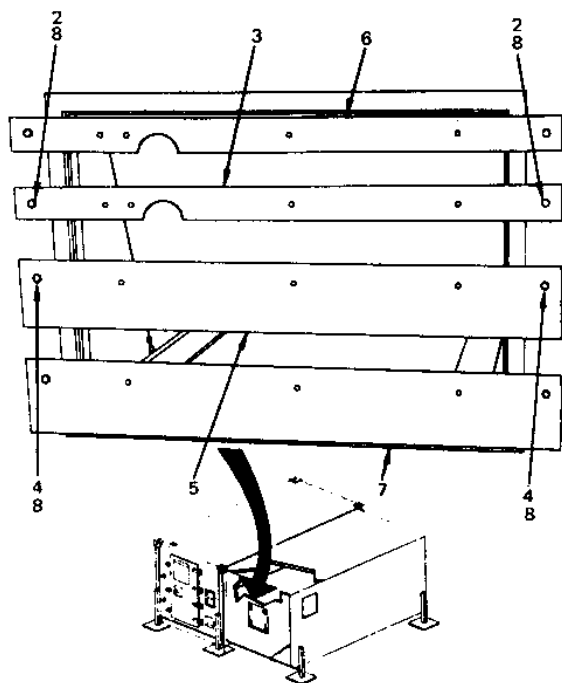

2. Position bar (3) and bar (5) between bars (6) and (7) of ECU shelf opening, on end wall. Install bolts (2) and (4) with washers (8).

3. Remove bolts (2) from top bar (6) and remove bar.

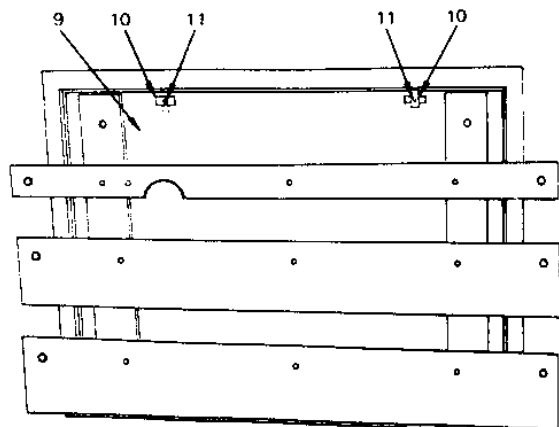
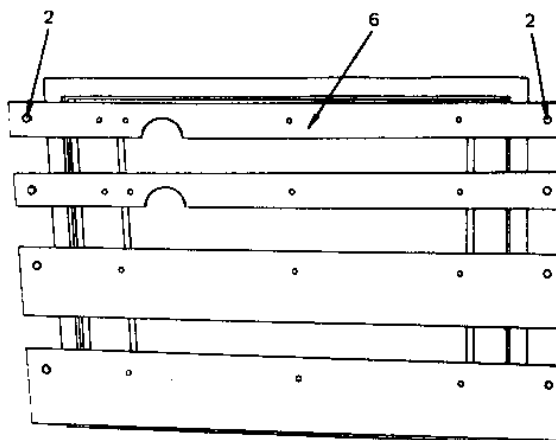

4. Close shelf (9), turn latches (10) to vertical position and tighten latch bolts (11).

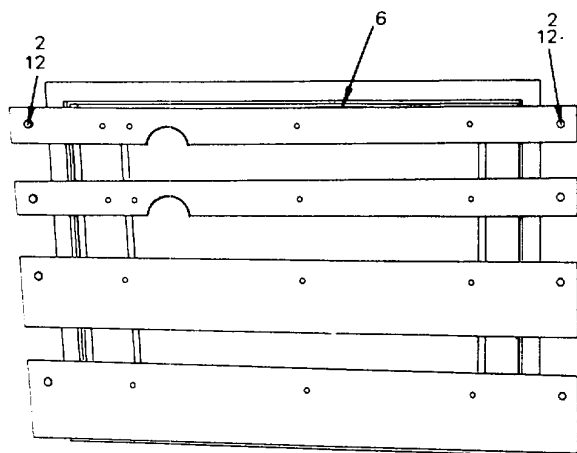

5. Position top bar (6) and install two bolts (2) with washers (12).

6. Close other ECU shelf and secure latches as in step 4.

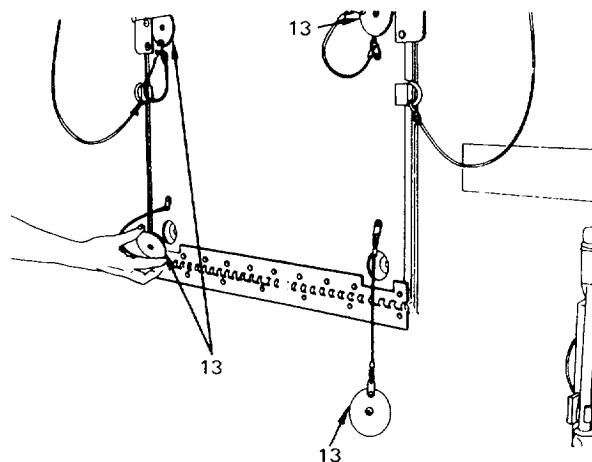

7. Insert four plugs (13) in each ECU shelf.

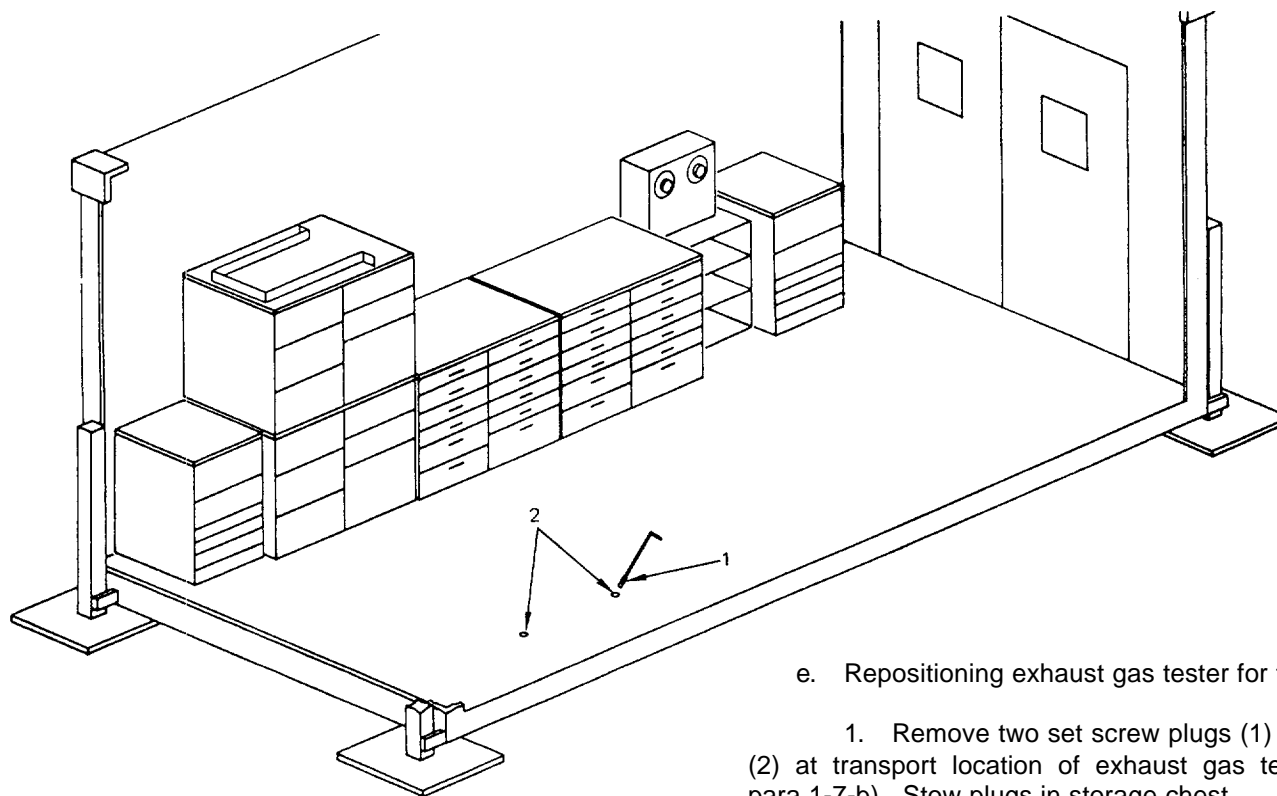

e. Repositioning exhaust gas tester for transport.

1. Remove two set screw plugs (1) from inserts (2) at transport location of exhaust gas tester. (See para 1-7-b). Stow plugs in storage chest.

2. Position tester (3) by rolling along floor to its transport location.

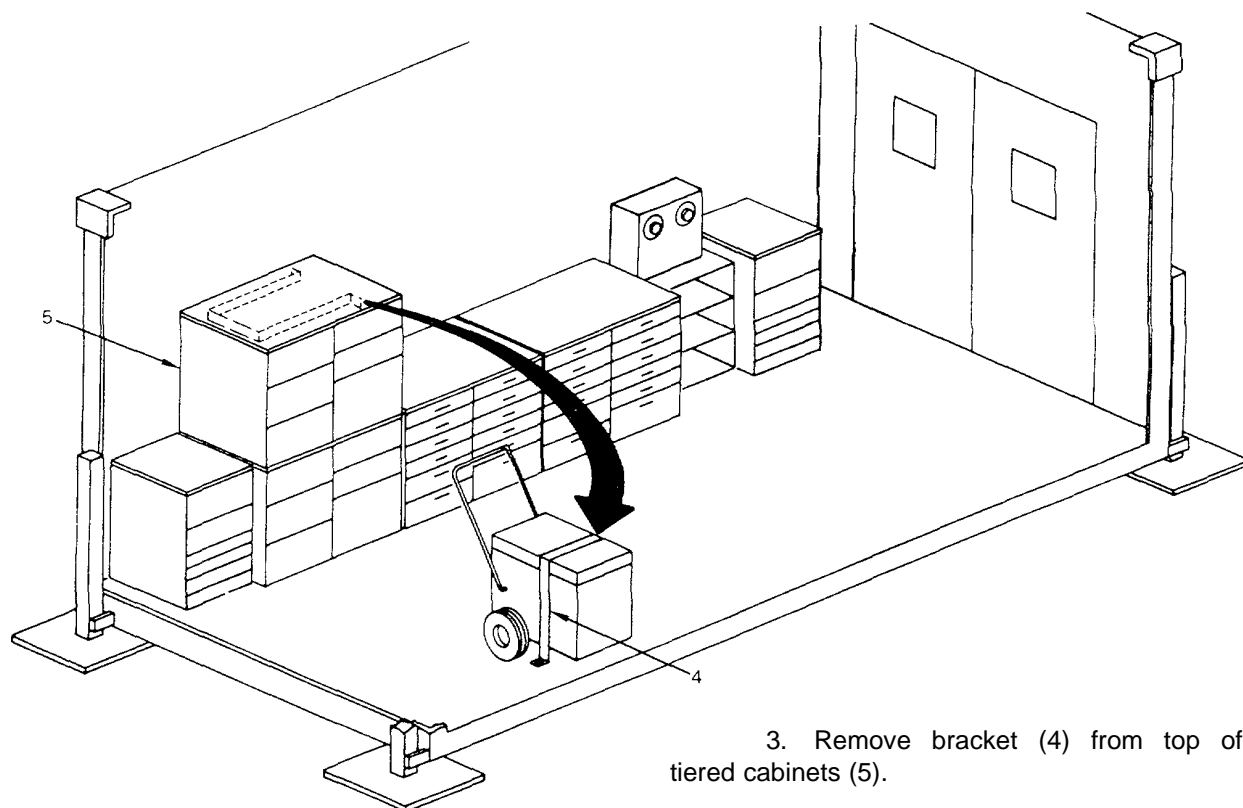
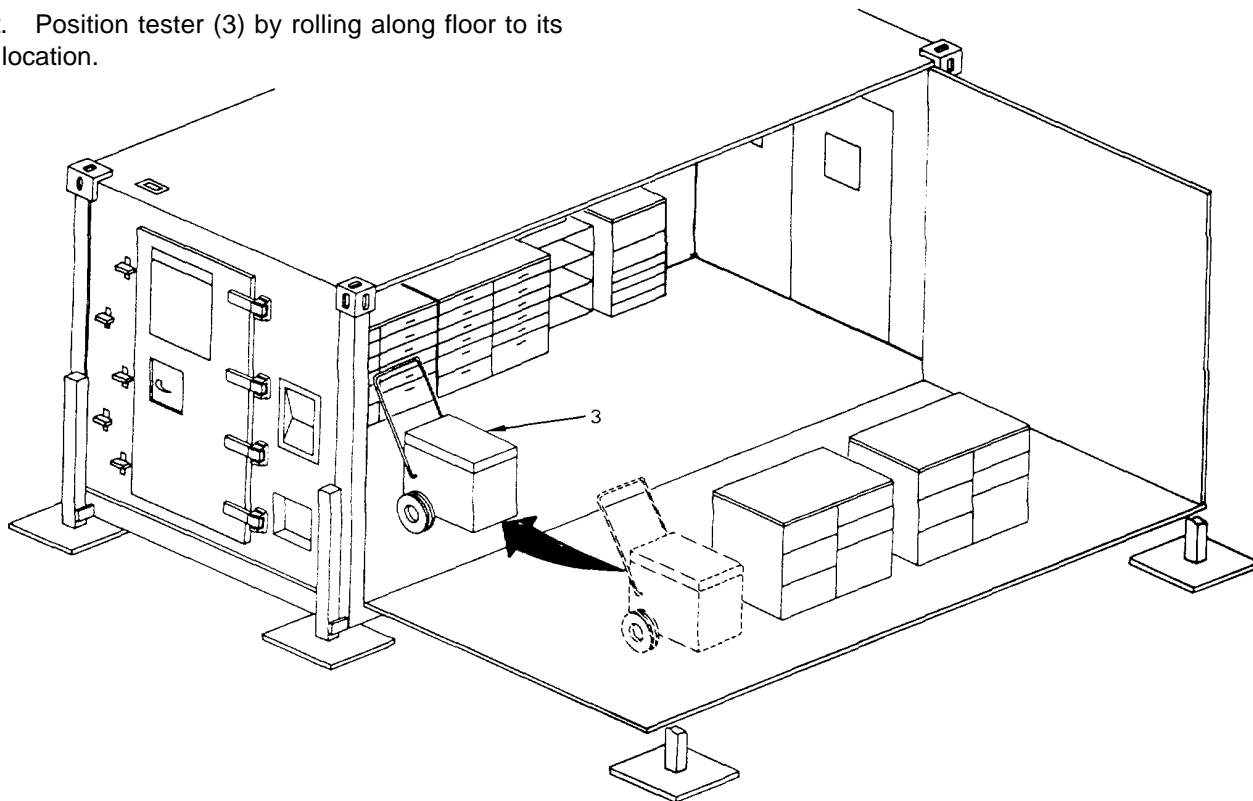

3. Remove bracket (4) from top of double tiered cabinets (5).

4. Position bracket (4) over top of tester (3).
Align holes in brackets with floor inserts.

5. Install two bolts (6) with washers (7).

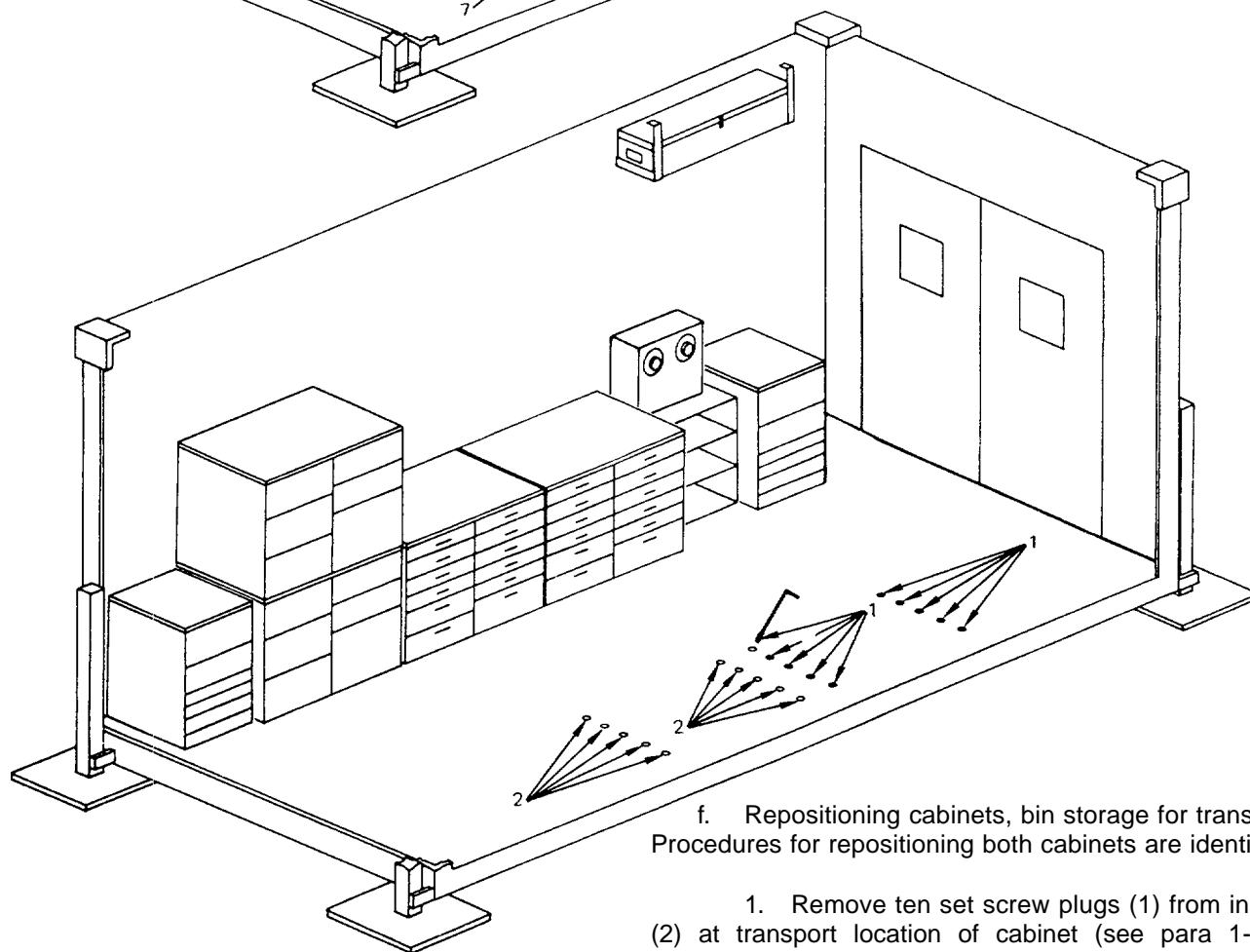
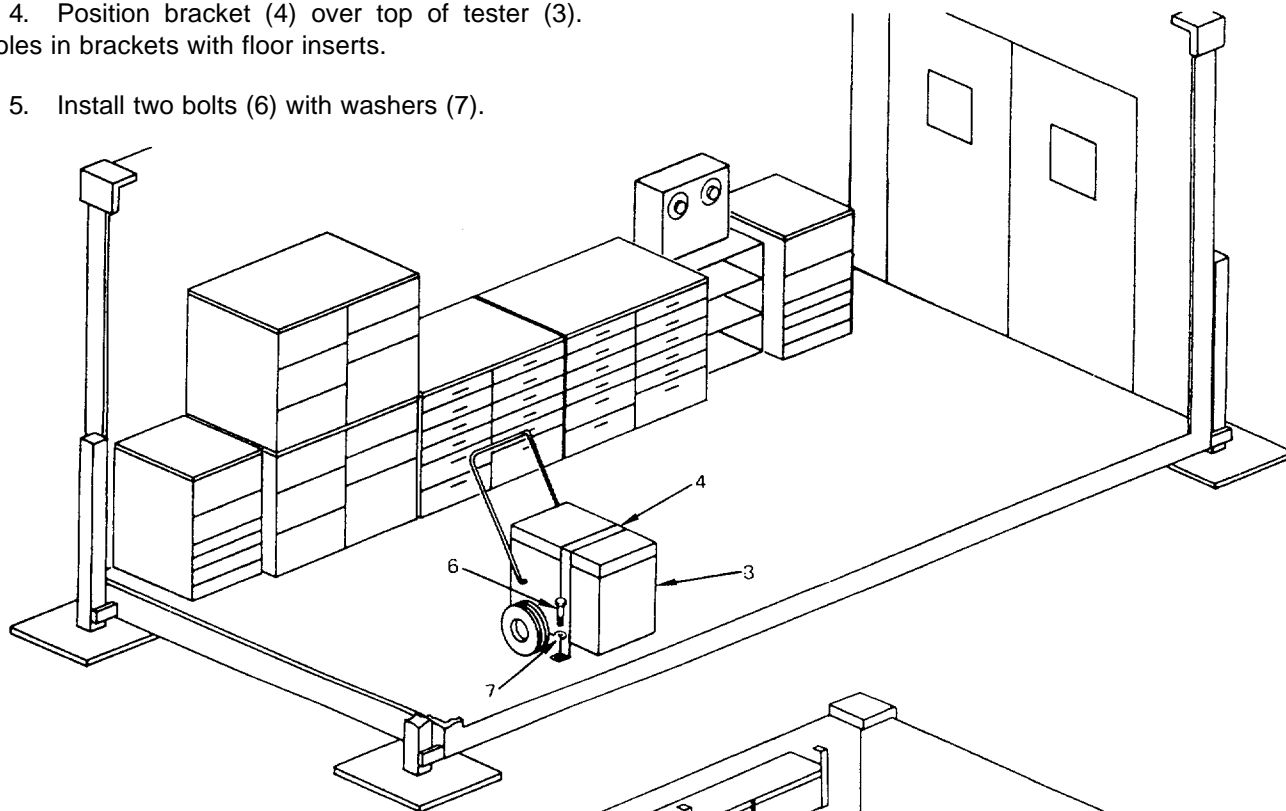

f. Repositioning cabinets, bin storage for transport.
Procedures for repositioning both cabinets are identical.

1. Remove ten set screw plugs (1) from inserts (2) at transport location of cabinet (see para 1-7-b).
Stow plugs in storage cabinet.

2. Reposition cabinet (3) by sliding along floor to transport position.

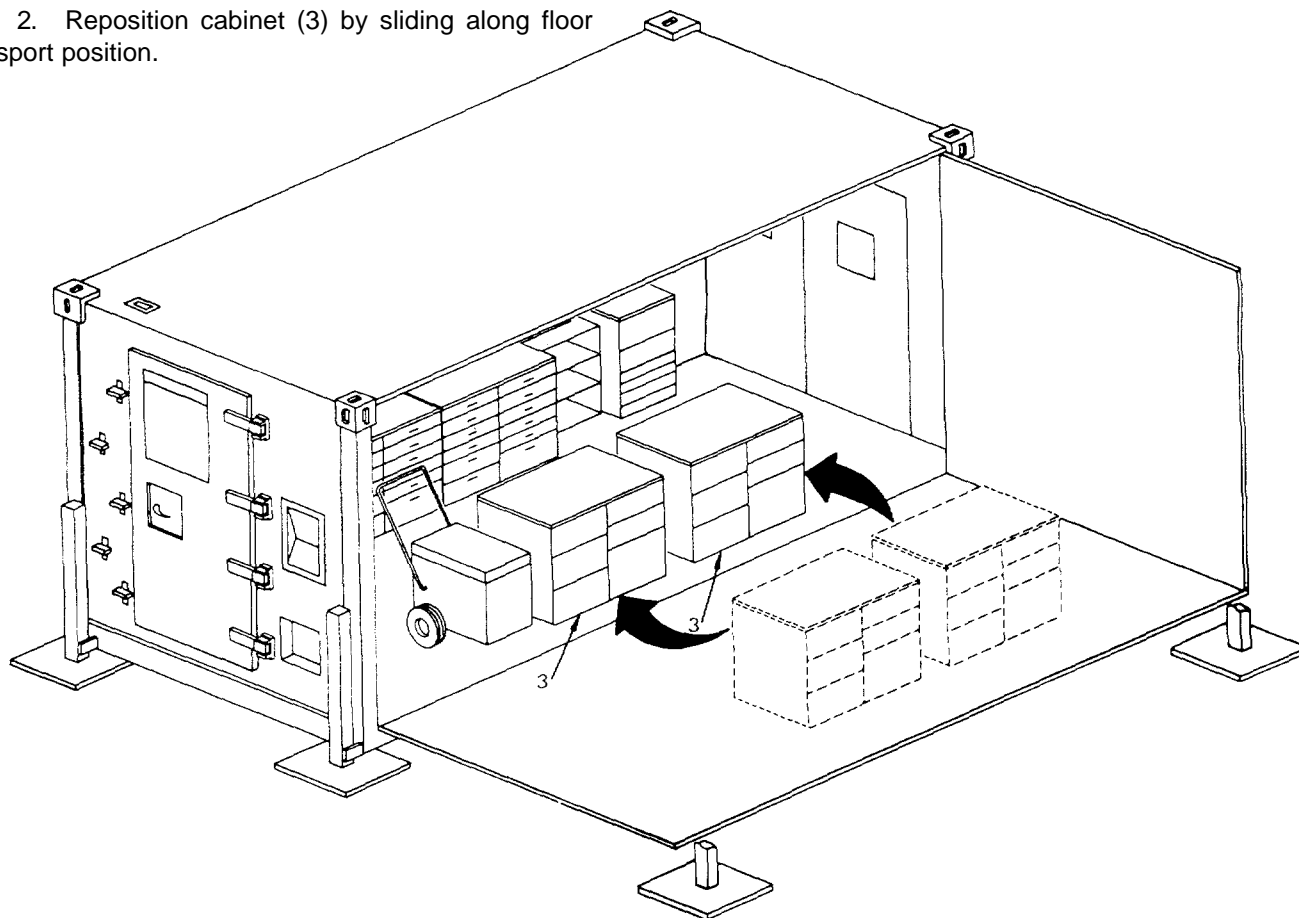

3. Aline holes (4) in cabinet brackets (5) with floor inserts and install ten bolts (6) with washers (7).

4. Repeat steps 1 thru 3 for second cabinet.

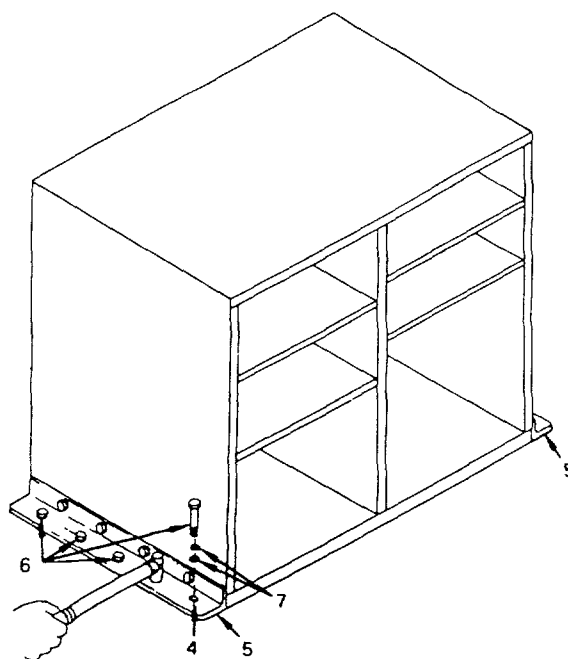

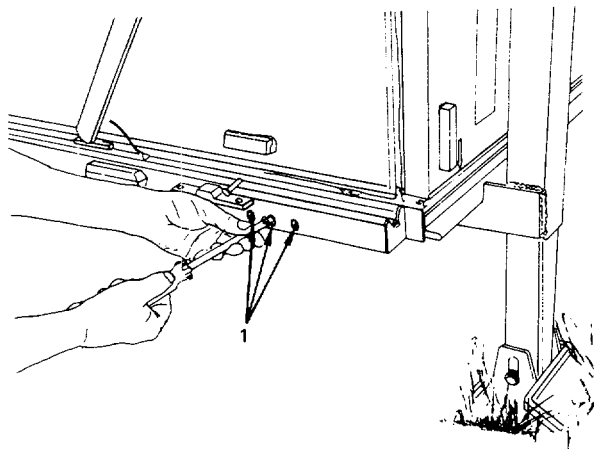

2-12. Storage procedures. In the event the Electric/Instrument Shop is to be placed in storage the provisions of TM 740-90-1, TM 743-200-1 and applicable shop equipment TM's will be followed.

2-13. Striking the shelter. Procedures for striking the shelter are contained in TM 10-5411-201-14. In addition, the following "Supplemental Instructions" will be observed.

a. Remove screws (1) at both corners of fold-out floor.

b. Install cable (3) and retainer block (2) with screws (1).

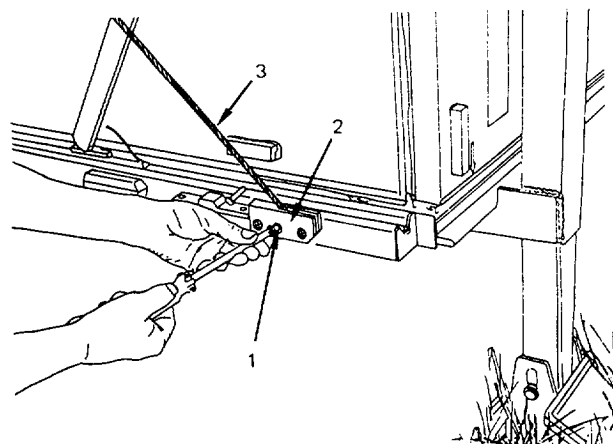

NOTE

When floor is lowered, (to allow roof clearance for folding) the devices securing fold-out floor counter-balance cables can be disengaged.

WARNING

When all equipment and materiel is stored on the stationary side of the shelter, the limited floor space presents a safety hazard to operating personnel. This is most critical during the raising and lowering of the roof panel. Failure to observe supplemental instructions could result in serious injury to personnel. Personnel inside the shelter could become trapped between the roof panel and equipment bolted to the floor.

c. Two people inside the shelter, using the support struts (1), will lower the roof panel (2) until two personnel outside can reach and hold the weight of the roof.

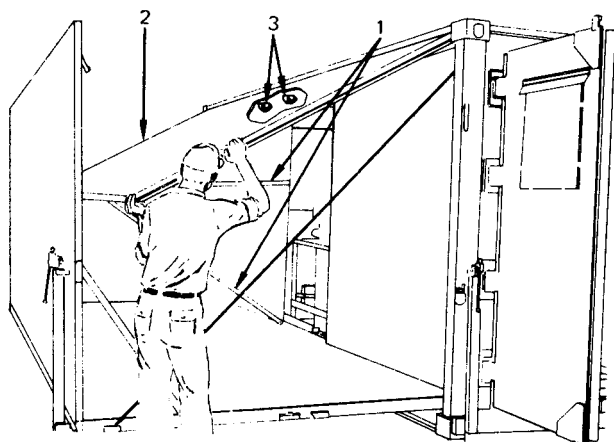
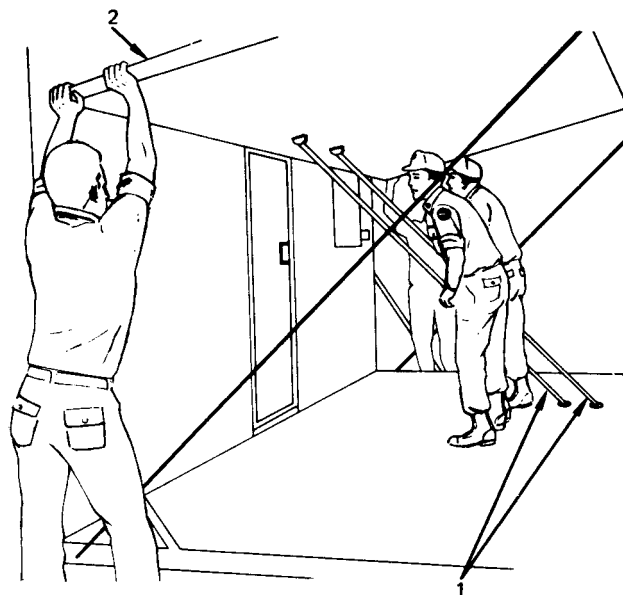

d. Inside personnel will shorten the struts (1) and secure to roof brackets (3). They will then move into position to assist outside personnel.

e. After all inside personnel are clear allow the roof panel (2) to close to the vertical position.

f. After the shelter has been folded as detailed in steps a thru e and prepared in accordance with TM 10-5411-201-14, the Electric/Instrument Shop is ready for transport or storage.

**CHAPTER 3
MAINTENANCE INSTRUCTIONS, AVIM**

**SECTION I. REPAIR PARTS, SPECIAL TOOLS,
TMDE, AND SUPPORT EQUIPMENT**

3-1. Common tools and equipment. For authorized common tools and equipment, refer to the Modified Table of Organization and Equipment (MTOE) applicable to the AVIM unit.

3-2. Torque values. All equipment or tools secured to the floor or walls of the shelter must be carefully tightened to specific torque limits. These torque limits are contained in Appendix F of this manual.

3-3. Special tools, TMDE, and support equipment. No special tools required.

3-4. Repair parts. Repair parts, hardware and bulk stock are listed in Appendix C of this manual.

SECTION II. SERVICE UPON RECEIPT

3-5. Checking equipment.

a. Once shelter has been erected, inventory for completeness of shop equipment.

b. Inspect equipment to ensure that all items are still firmly secured to floor and wall mounts. In the event an item has broken loose and been damaged or has caused damage to other equipment of the shelter a DD Form 6, Packaging, Improvement Report will be submitted.

c. After equipment has been positioned to the recommended operational floor plan check all items requiring service. Preventive maintenance (PM) and preoperational services will be performed IAW applicable equipment TM's.

SECTION III. MAINTENANCE PROCEDURES**3-6. Insert Fasteners and Bolts - Inspect****3-6**

This task covers: Inspection of all insert fasteners and bolts common to the Electric/Instrument Shop

INITIAL SETUPTools:

Torque wrench, 0-600 inch pounds range

Tool Kit, Electrical Repairer, Army Aircraft, NSN 5180-00-323-4915

Personnel Required:

68F Aircraft Electrician

Reference Information:

TM 55-1500-204-25/1

INSPECTION**NOTE****Go to step 2 if bolts are serviceable.**

1. Inspect bolts.

- a. Remove bolt (1) that will not tighten to specific torque. (App F).

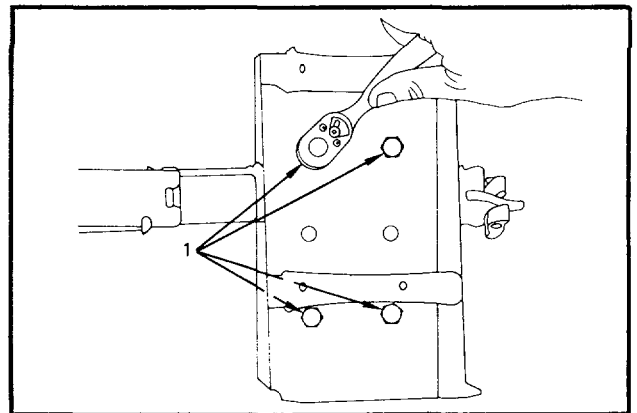

GO TO NEXT PAGE

3-6. Insert Fasteners and Bolts - Inspect (Cont)

3-6

b. Inspect bolt (1) for damaged threads or rounded head.

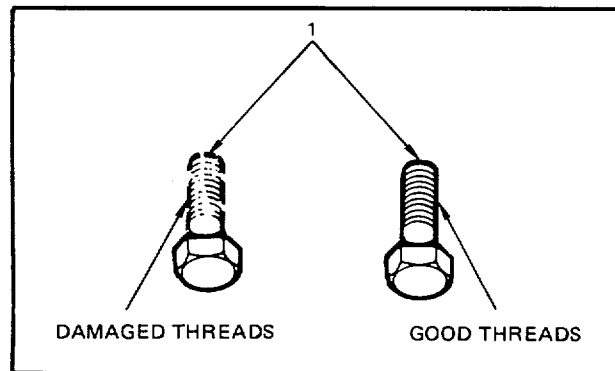

c. Install new bolt (1) as required.

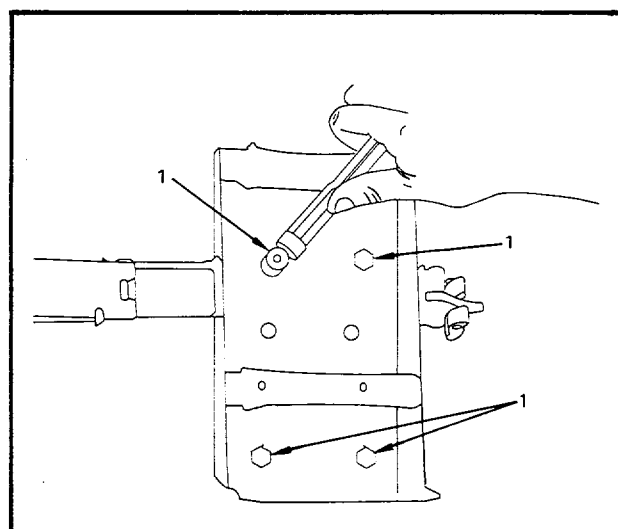

2. Inspect insert when bolt is not damaged.

a. Visually inspect insert (2) with flashlight (3).

b. If insert threads are damaged or insert has broken loose in adhesive potting, replace. See TASK 3-7.

END OF TASK

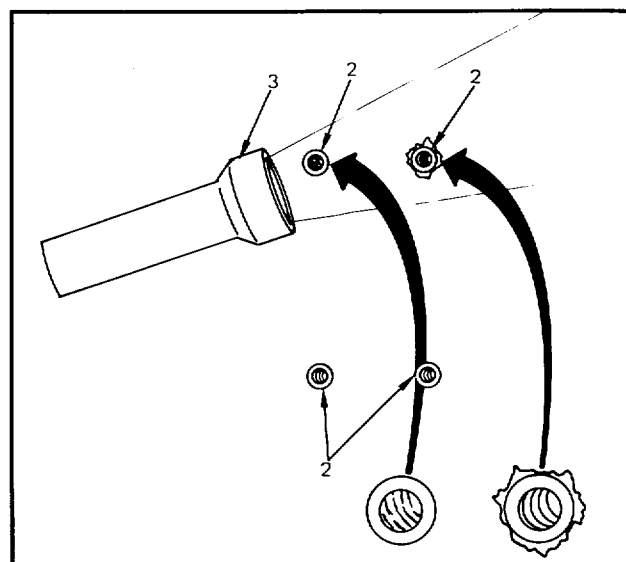

3-7. Insert Fasteners - Replace

3-7

This task covers: Replacement of insert fasteners

INITIAL SETUPPersonnel Required:

68F Aircraft Electrician

Reference Information:

TM 10-5411-201-14

WARNING

Methylethylketone (MEK), used to clean replacement inserts, is flammable and toxic. Use only in well ventilated areas. Breathing vapors can cause headaches and nausea. Repeated contact with skin can cause irritation. If irritation persists see a doctor. Contact with eyes, wash immediately with water for 15 minutes and seek medical attention.

WARNING

Safety goggles will be worn when drilling and cleaning holes for insert replacement. Flying chips can cause eye injury or even blindness.

END OF TASK

3-8. Fixtures - Fire Extinguisher - Removal/Installation**3-8**

This task covers: Removal and installation of the fire extinguisher

INITIAL SETUP

Personnel Required:
68F Aircraft Electrician

REMOVAL/INSTALLATION

Release/install clamp (1) securing fire extinguisher (2) in bracket (3) and remove/install fire extinguisher.

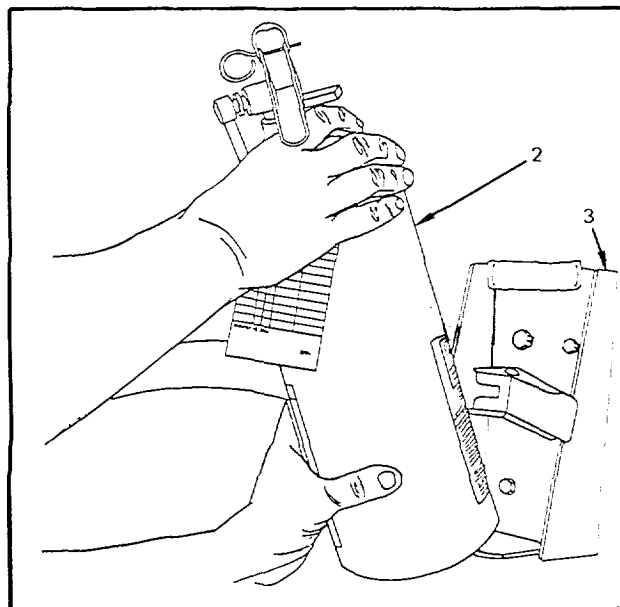
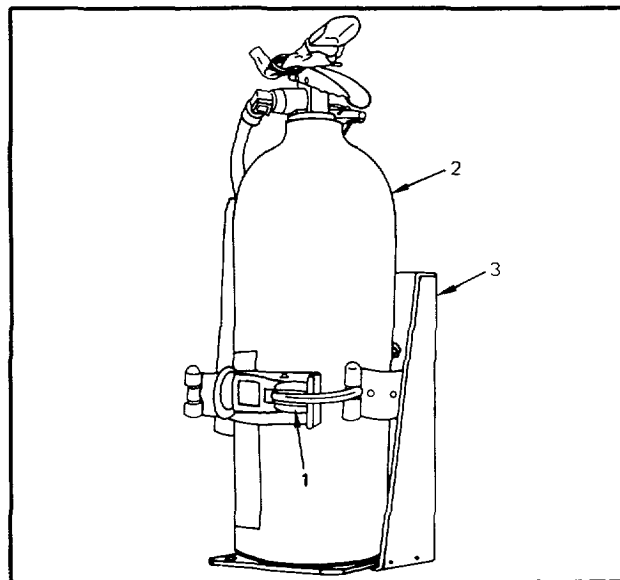
END OF TASK

3-9. Fixtures - Fire Extinguisher Mounting - Inspect

3-9

This task covers: Inspection of fire extinguisher mounting

INITIAL SETUPTools:

Torque wrench, 0-600 inch-pound range
Tool Kit, Electrical Repairer, Army Aircraft,
NSN 5180-00-323-4915

Reference Information:

TM 55-1500-204-25/1

Equipment Condition:

Fire Extinguisher
Removal/Installation TASK 3-8

Personnel Required:

68F Aircraft Electrician

INSPECTION

1. Check fire extinguisher bracket (1) for looseness.
2. Check torque (App F) on mounting bolts (2) when loose.

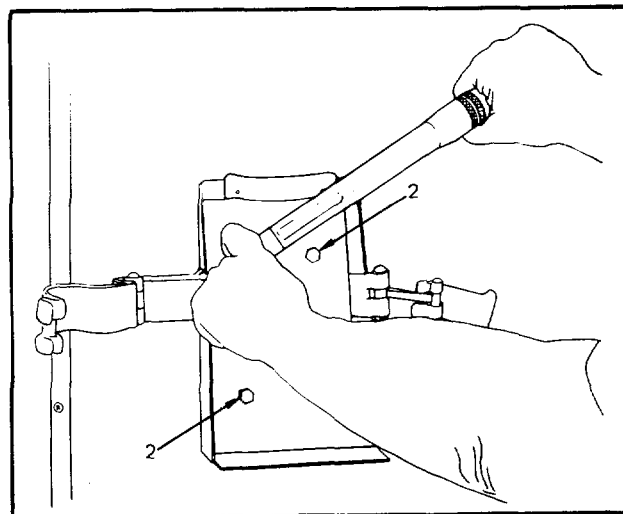
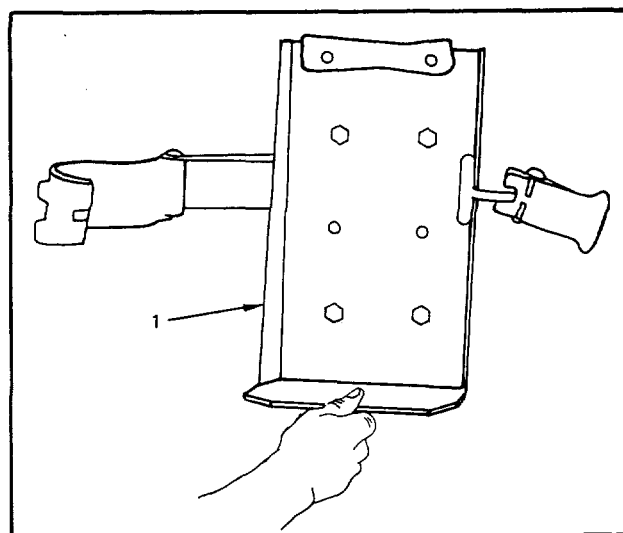

GO TO NEXT PAGE

3-9. Fixtures - Fire Extinguisher Mounting - Inspect (Cont)

3-9

3. Bolt(s) (2) will not tighten to specification, remove bolts and bracket (1). See TASK 3-6.

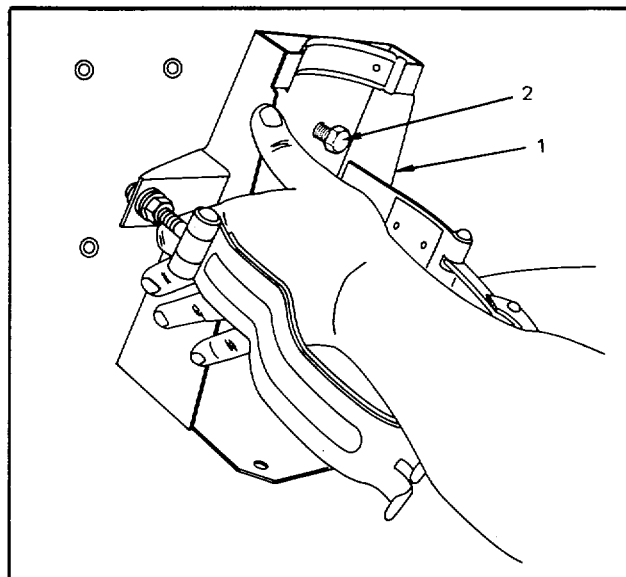

4. Position fire extinguisher bracket (1) and align bolt holes with wall inserts and install bolts (2) with washers (3).

NOTE

Four additional wall inserts, inside cargo door on end wall, have been provided as an alternate fire extinguisher mounting point.

END OF TASK

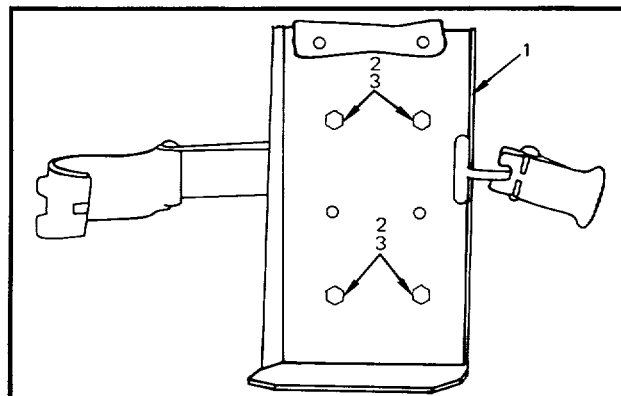

3-10. Water/Oil Separator Mounting - Inspect**3-10**

This task covers: Inspection of water/oil separator mounting

INITIAL SETUPTools:

Torque wrench, 0-600 inch-pound range

Tool Kit, Electrical Repairer, Army Aircraft, NSN 5180-00-323-4915

Personnel Required:

68F Aircraft Electrician

Reference Information:

TM 55-1500-204-25/1

INSPECTION

1. Check water/oil separator bracket (1) for looseness.

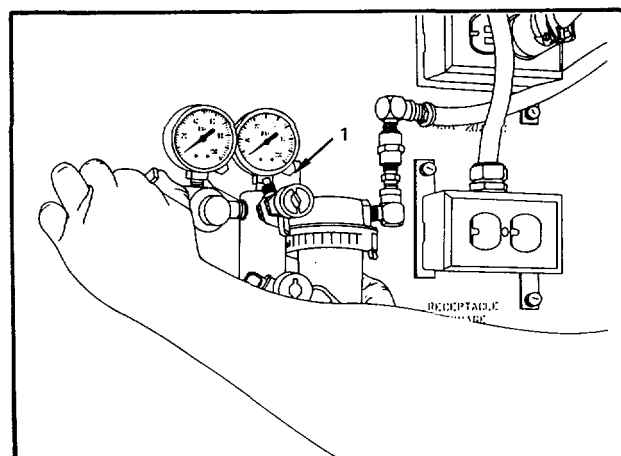

2. Check torque (App F) on mounting bolts (2) when loose.

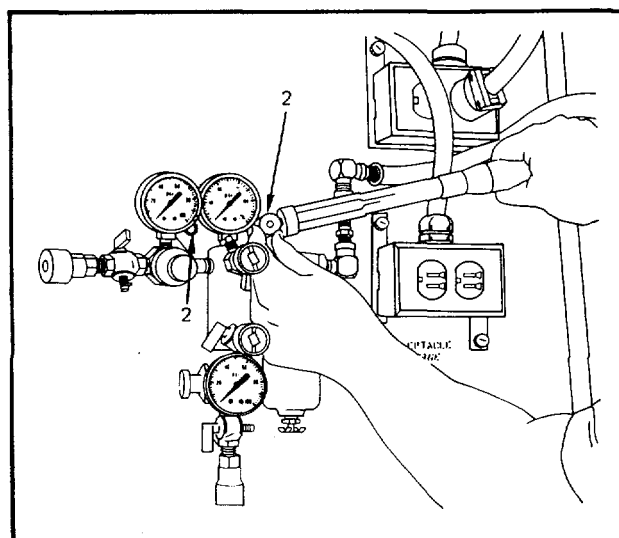

GO TO NEXT PAGE

3-10. Water/Oil Separator Mounting - Inspect (Cont)

3-10

3. Bolt(s) (2) will not tighten to specification, remove bolts (2) and water/oil separator (1). See TASK 3-6.

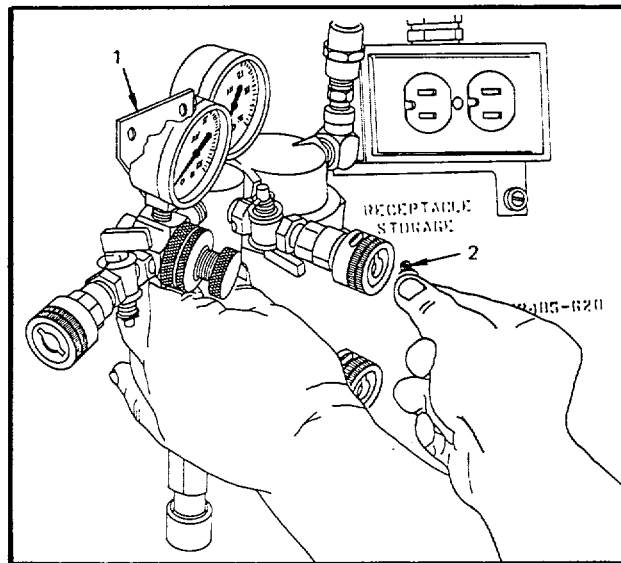

4. Position water/oil separator (1) over wall inserts and install bolts (2) with washers (3).

END OF TASK

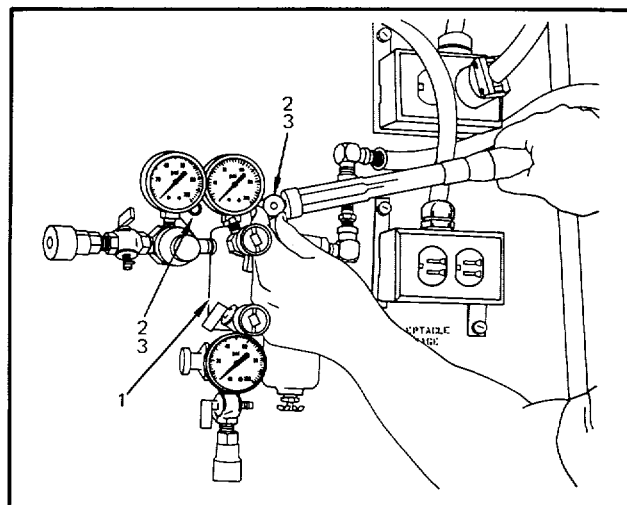

3-11. Water/Oil Separator Air Hose and Fittings - Inspect

3-11

This task covers: Inspection of air hose and fittings

INITIAL SETUP

Tools:

Tool Kit, Electrical Repairer, Army Aircraft, NSN 5180-00-323-4915

Personnel Required:

68F Aircraft Electrician

INSPECTION

WARNING

Make sure compressed air supply is disconnected before attempting any work on the water/oil separator. Do not direct compressed air near eyes or directly against skin. Wear goggles; high pressure air against eye can cause blindness.

1. Check air hose (1); replace if checking or cracks are visible. See TASK 3-12.

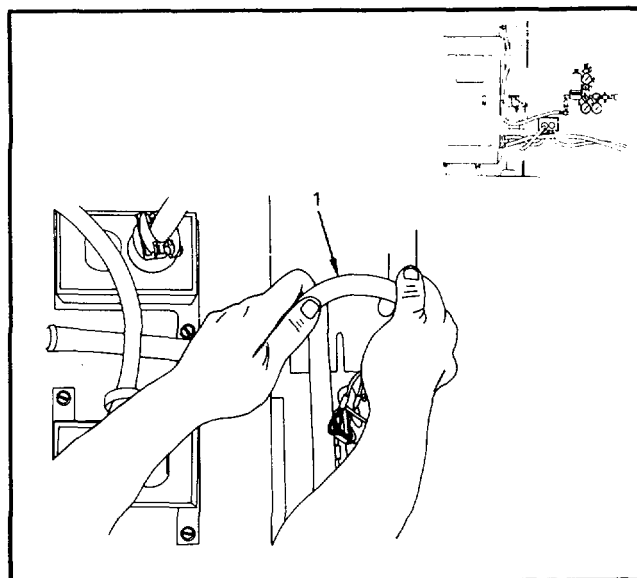

GO TO NEXT PAGE

3-11. Water/Oil Separator Air Hose and Fittings - Inspect (Cont)

3-11

2. Check threads on nipple (2) outside shelter.

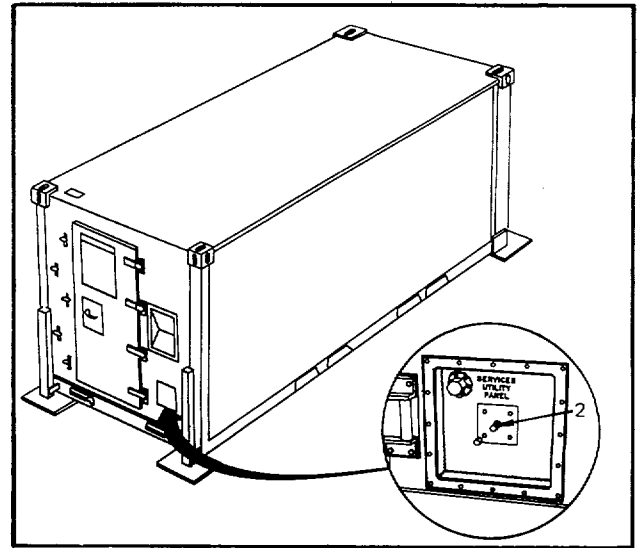

3. Ensure dust cover (3) is available and used as required.

END OF TASK

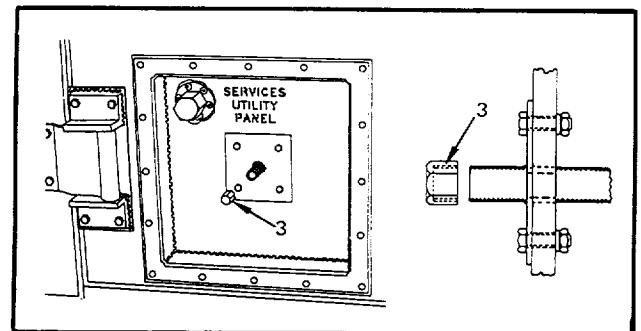

3-12. Fixtures - Water/Oil Separator Air Hose - Replace**3-12**

This task covers: Replacement of hose assembly

INITIAL SETUP

Tools:

Tool Kit, Electrical Repairer, Army Aircraft, NSN 5180-00-323-4915

Materiel:

Hose, Non-metallic

Personnel Required:

68F Aircraft Electrician

REPLACEMENT

WARNING

Make sure compressed air supply is disconnected before attempting any work on the water/oil separator. Do not direct compressed air near eyes or directly against skin. Wear goggles; high pressure air against eyes can cause blindness.

1. Remove both loop clamps (1) from defective hose (2).

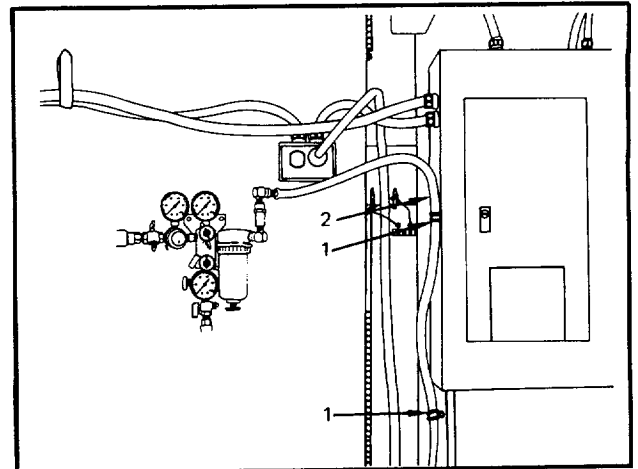

GO TO NEXT PAGE

3-12. Fixtures - Water/Oil Separator Air Hose - Replace (Cont)**3-12**

2. With knife (3) slit hose lengthwise from protective cap (4) to end of fitting (5). (Approx 1 1/2 inches).

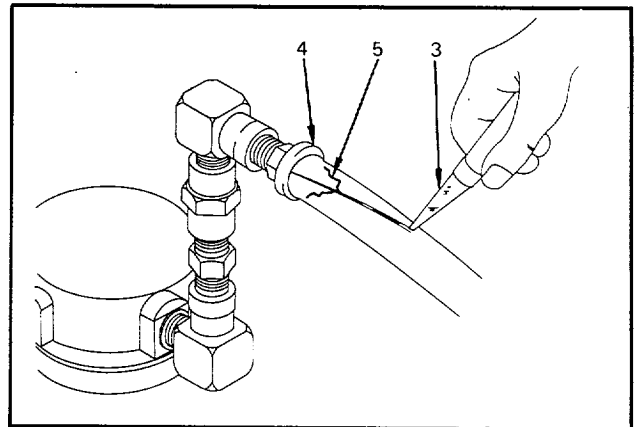

3. Bend hose (2) back over fitting (5) and snap off with quick tug.

4. Repeat steps 2 and 3 at other end of hose.

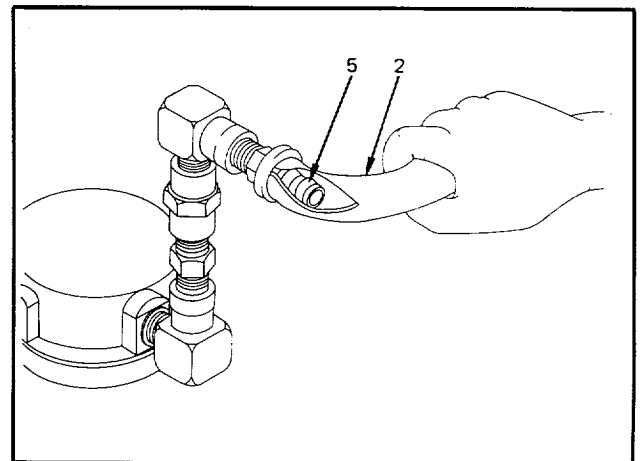

5. Slide loop clamps (1) over new hose assembly (2).

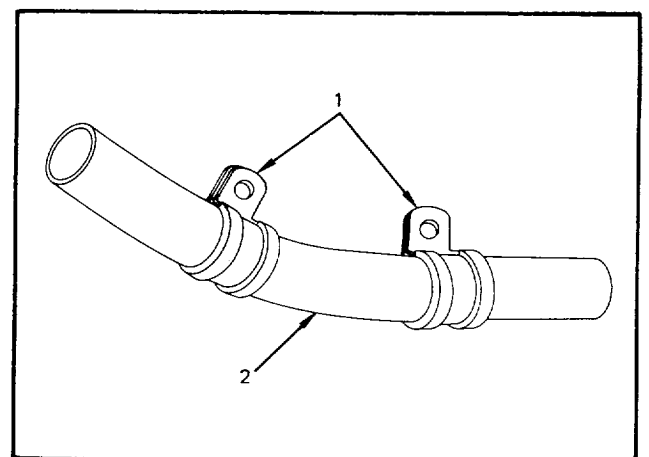

GO TO NEXT PAGE

3-13

3-12. Fixtures - Water/Oil Separator Air Hose - Replace (Cont)**3-12**

6. Push hose (2) on fitting (5) until end bottoms underneath protective cap (4).

Repeat at other end of hose.

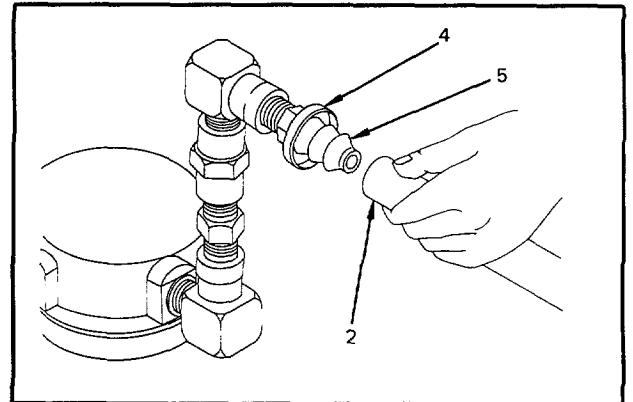

7. Install loop clamps (1) in original position and secure.

END OF TASK

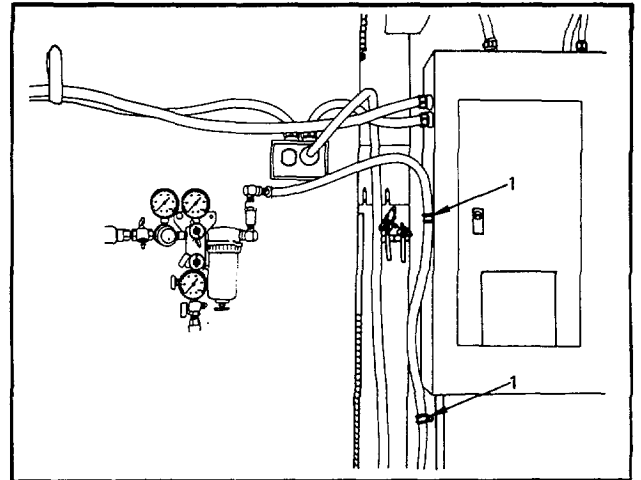

3-13. Fixtures - Water Feed Thru Connector - Inspect

3-13

This task covers: Inspection of connector

INITIAL SETUP

Personnel Required:
68F Aircraft Electrician

INSPECTION

1. Check condition of threads on both ends of water feed thru connector (1).
2. See that dust caps (2) are available and used as required.

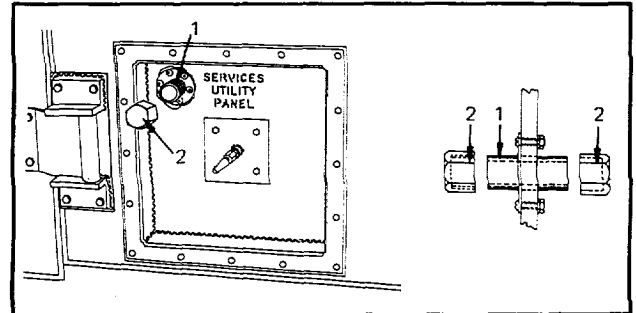

3. Ensure that weld (3) on connector (1) is not cracked or broken. If defective, see TASK 3-14.

END OF TASK

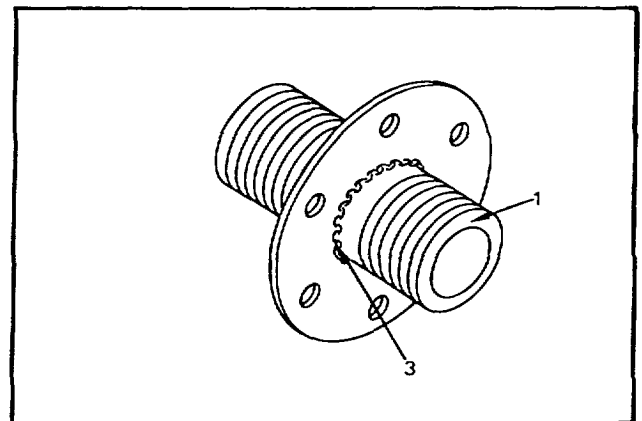

3-14. Fixtures - Water Feed Thru Connector - Replace

3-14

This task covers: Replacement of connector

INITIAL SETUP

Tools:

Tool Kit, Electrical Repairer, Army Aircraft, NSN 5180-00-323-4915

Materiel:

New feed thru connector - App E

Adhesive, Sealant NSN 8040-00-877-9872

Personnel Required:

68F Aircraft Electrician and Helper

REPLACEMENT

1. Have helper hold nut (1) inside shelter.
2. Remove six screws (2), securing connector (3) in place.
3. Remove connector (3) from wall and scrape off old sealant (4).
4. Details for fabrication of new connector are in App E.

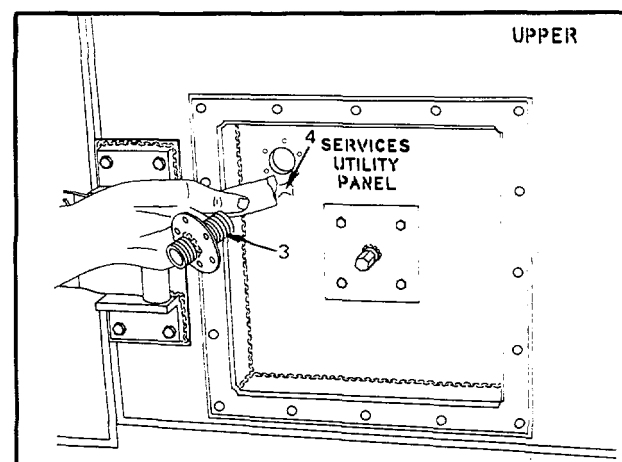
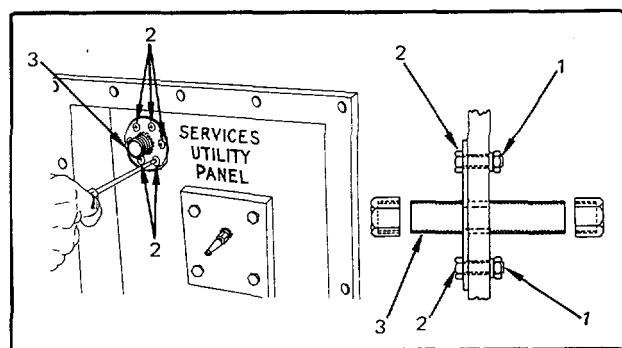

GO TO NEXT PAGE

3-14. Fixtures - Water Feed Thru Connector - Replace (Cont)

3-14

5. Apply adhesive on side of collar (5) toward long end of connector (3).
(Use adhesive, item 1, App D).

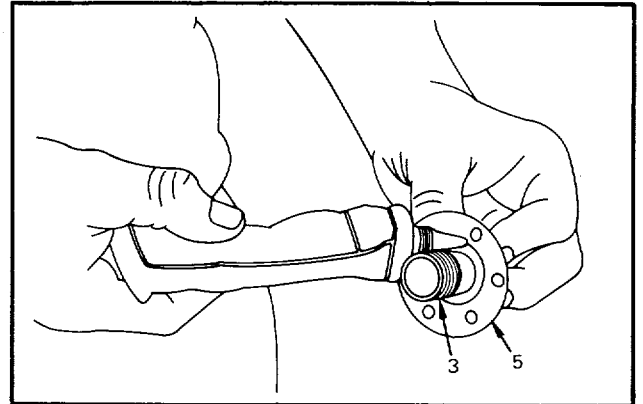

6. Install new connector (3) from outside of shelter; long end of nipple thru hole.

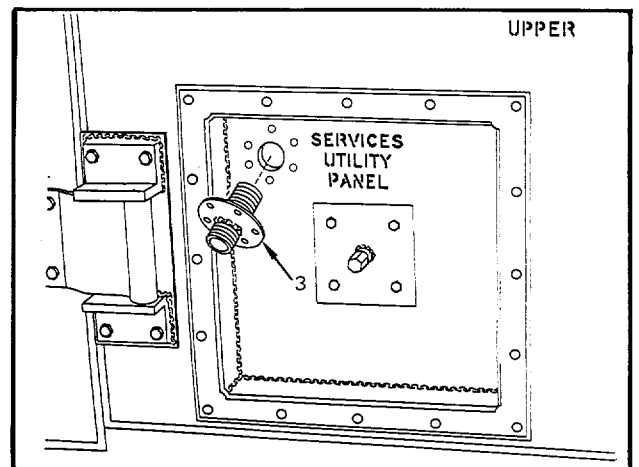

7. Replace six screws (2), have helper install washers and nuts (1), inside shelter, tighten securely.

END OF TASK

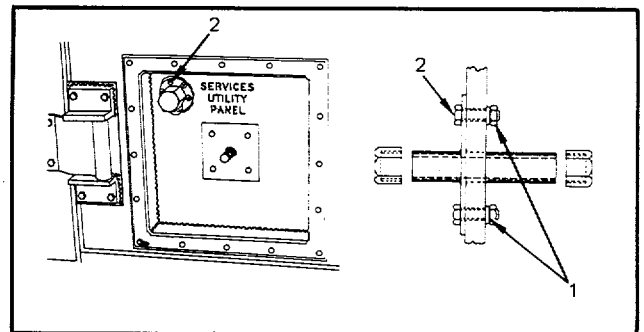

3-15. Ground Rod/Strap - Inspect**3-15**

This task covers: Inspection of ground rod and strap

INITIAL SETUPTools:

Tool Kit, Electrical Repairer, Army Aircraft, NSN 5180-00-323-4915
Multimeter

Personnel Required:

68F Aircraft Electrician

Reference Information:

TM 55-1500-04-25/1
TC 11-6

INSPECTION**WARNING**

HIGH VOLTAGE exists in the electrical system of this shop. All electrical inspections, repairs or replacements shall be performed with the power OFF and only by qualified electricians. Serious shock hazards exist which could result in serious injury or death to personnel.

1. Check ground rod.
 - a. Ensure ground rod (1) is firmly driven into ground.
 - b. Ensure that clamp (2) and screw (3) are securely fastened.
 - c. Ensure there is no sign of oxidation around clamp (2) or screw (3).
 - d. Check that ground strap (4) is not frayed or broken.

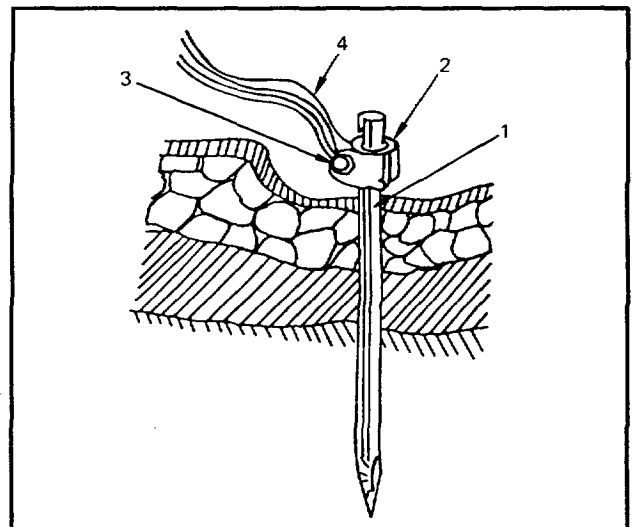

GO TO NEXT PAGE

3-15. Ground Rod/Strap - Inspect (Cont)

3-15

2. Check ground strap (4) connection at terminal lug (5) on shelter power entry panel (6).

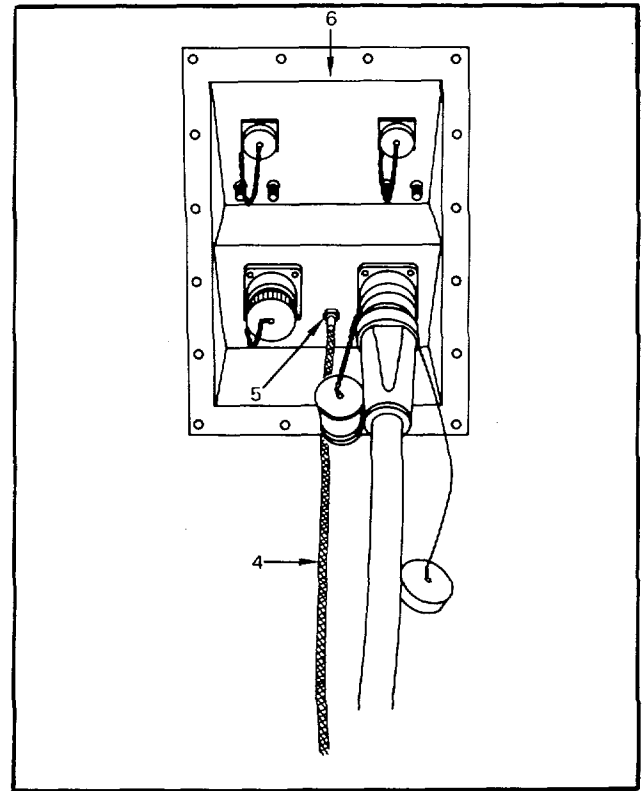

3. Use multimeter (7), check condition of ground.
(Use TC 11-6)

- a. Set for AC voltage
- b. Red lead on shelter
- c. Black lead on ground strap
- d. 0-5 volts - adequate ground
- e. Over 5 volts - poor ground

END OF TASK

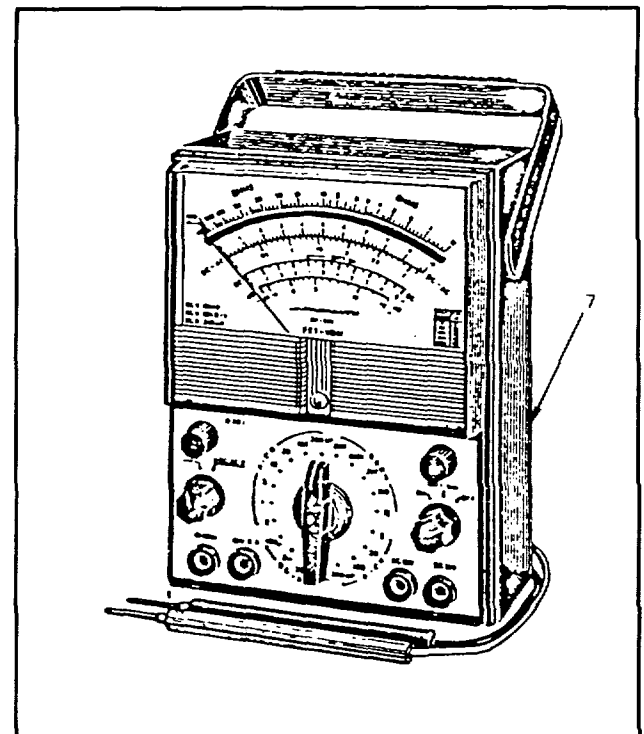

NOTE

The following special brackets and fabricated components were fabricated for use in the Electric/Instrument Shop. Detailed drawings of the brackets/components are in Appendix E.

Bracket - Cabinet, Bin Storage

Bracket - Storage Chest

Bracket - Exhaust Gas Tester

Tool Box Rack Mounting

Support Frame, ECU

Security Bars, ECU

Book Rack Mounting

The TASK of INSPECTION, REPAIR and REPLACEMENT for all brackets and components is typical. The book rack is used to show the required maintenance procedures. All other brackets/components will be treated the same.

3-16. Special Brackets and Fabricated Components, Book Rack - Inspect**3-16**

This task covers: Inspection of book rack

INITIAL SETUPTools:

Torque wrench, 0-600 inch-pound range

Tool Kit, Electrical Repairer, Army Aircraft, NSN 5180-00-323-4915

Personnel Required:

68F Aircraft Electrician

Reference Information:

TM 55-1500-204-25/1

INSPECTION

1. Check book rack (1) for looseness.

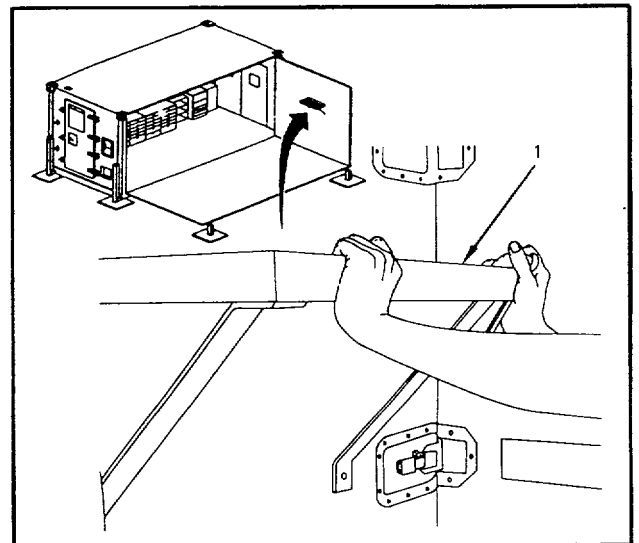

2. Check torque (App F) on mounting bolts (2) when loose.

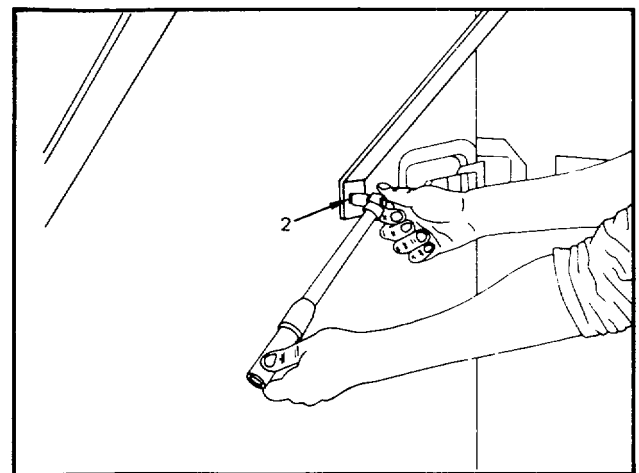

GO TO NEXT PAGE

3-18. Special Brackets and Fabricated Components, Book Rack - Inspect (Cont)

3-16

3. Bolt(s) (2) will not tighten to specification, remove bolts (2) and book rack (1). See TASK 3-6.

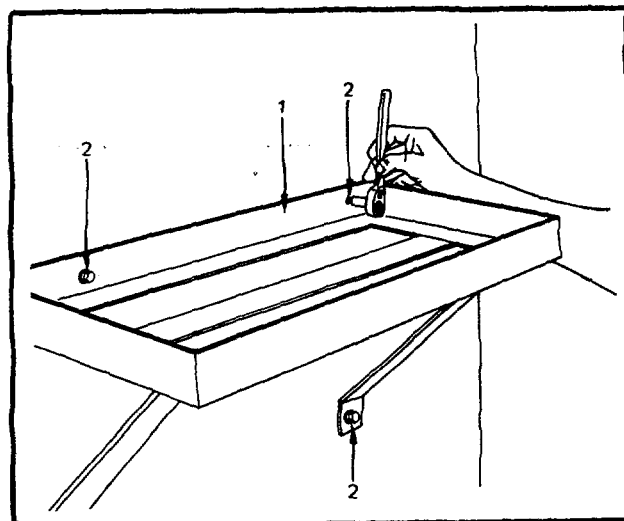

4. Check rack (1) for bends, cracks, or breaks in welds.

5. Any damage to book rack (1) requires repair. See TASK 3-17.

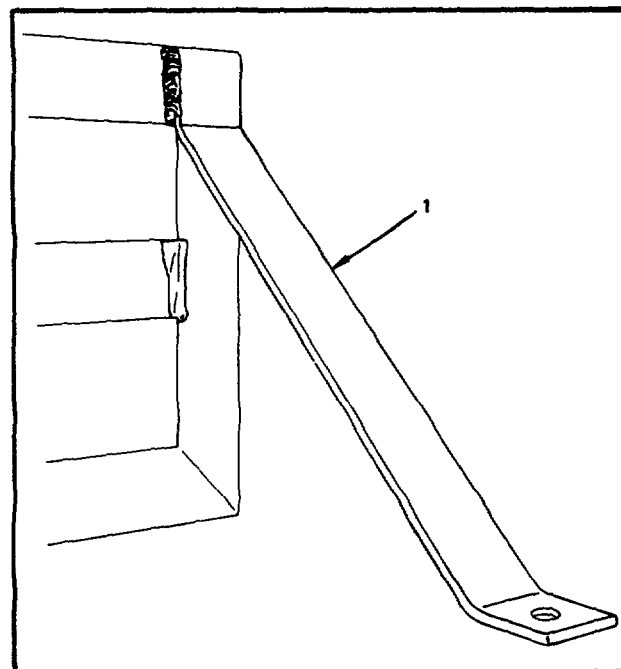

GO TO NEXT PAGE

3-16. Special Brackets and Fabricated Components, Book Rack - Inspect (Cont)

3-16

6. After Repair.

a. Position rack (1) and align holes (3) in rack (1) with wall inserts.

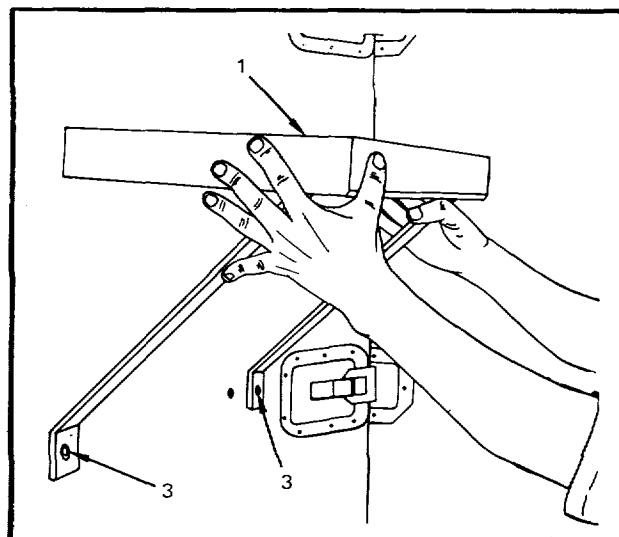

b. Install bolts (2) with washers (4).

END OF TASK

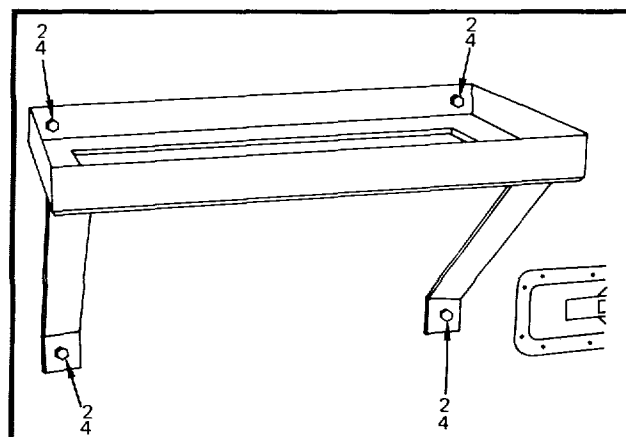

3-17. Special Brackets and Fabricated Components, Book Rack - Repair**3-17**

This task covers: Repair of the book rack

INITIAL SETUPTools:Tool Kit, Electrical Repairer, Army Aircraft,
NSN 5180-00-323-4915

Welder, elect arc

Torque wrench, 0-600 inch-pound range

Material:

Rod, welding

Primer coating NSN 8010-00-297-0593

Enamel, white NSN 8010-00-159-4520

Personnel Required:

44E Machinist

68F Aircraft Electrician

Reference Information:

TM 55-1500-204-25/1

MIL-W-8604A

TM 43-0139

REPAIR**WARNING**

Extreme care must be taken when performing all types of welding operations. Serious health and fire hazards exist. Harmful light rays can cause eye injury or even blindness. Protective face masks and goggles must be used as well as other special clothing to reduce risks. Poisonous fumes, burns, electric shock, fire and explosion hazards are some of the additional possibilities of injury associated with welding operations. It is essential that all safe practices be strictly observed.

1. Remove four bolts (2) holding book rack (1) to wall, remove rack.

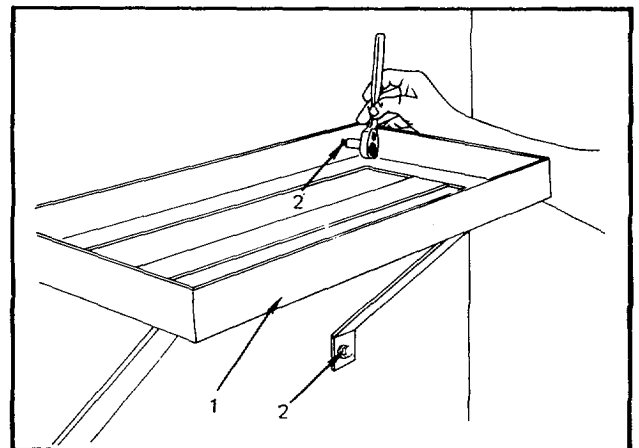

GO TO NEXT PAGE

3-17. Special Brackets and Fabricated Component, Book Rack - Repair (Cont)

3-17

2. Repair cracks or breaks in rack (1) by welding; IAW TM 55-1500-20425/1 and MIL-W-8604A. (Use welding rod, item 6; App D or equivalent).

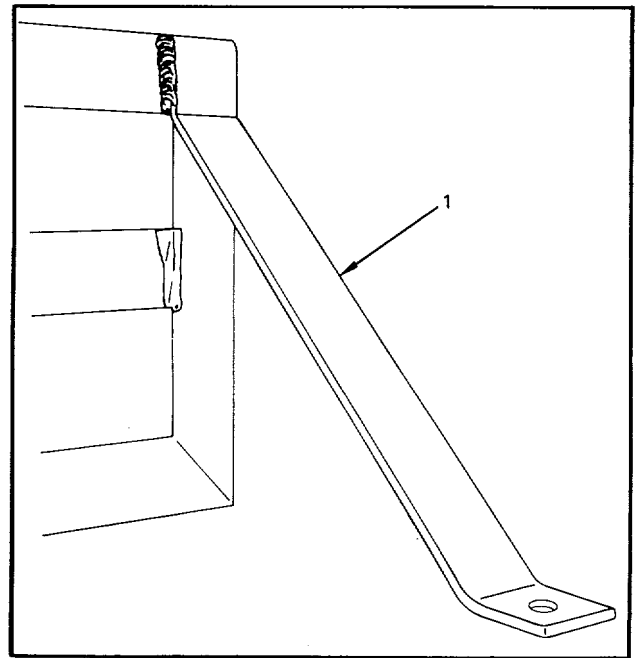

NOTE

Replacement of book rack is required when any repair results in a change to the original design or dimensions of the book rack. See TASK 3-18.

3. After repair.

- a. Touch up paint, as required. (Use primer, item 5, and enamel, item 4, App D.)
- b. Position book rack (1) on wall and align wall inserts with holes in rack (3).

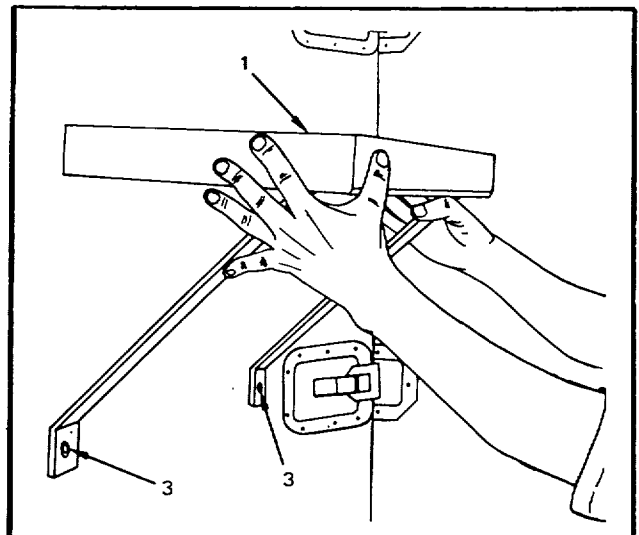

GO TO NEXT PAGE

3-17. Special Brackets and Fabricated Component, Book Rack - Repair (Cont)

3-17

4. Install four bolts (2) in book rack (1) with washers (4).

END OF TASK

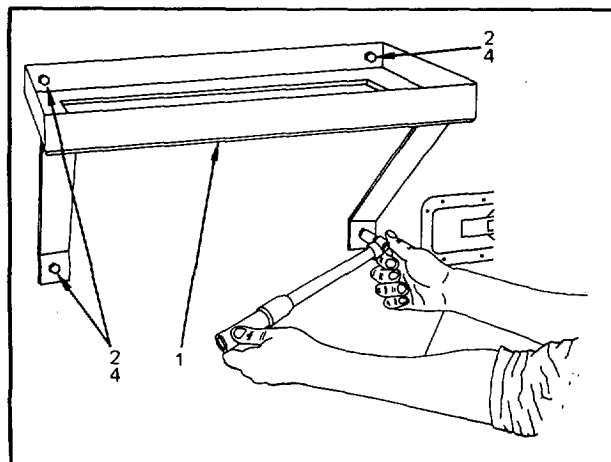

3-18. Special Brackets and Fabricated Components, Book Rack - Replace**3-18**

This task covers: Replacement of the book rack

INITIAL SETUPTools:

Tool Kit, Electrical Repairer, Army Aircraft,
NSN 5180-00-323-4915
Torque wrench 0-600 inch-pound range

Materiel:

Primer, coating NSN 8010-00-297-0593
Enamel, white NSN 8010-00-159-4520

Personnel Required:

68F Aircraft Electrician

Reference Information:

TM 55-1500-204-25/1
TM 43-0139

REPLACEMENT

1. Remove four bolts (2) from book rack (1) and remove rack.
2. Details for fabrication of new book rack are in App E.

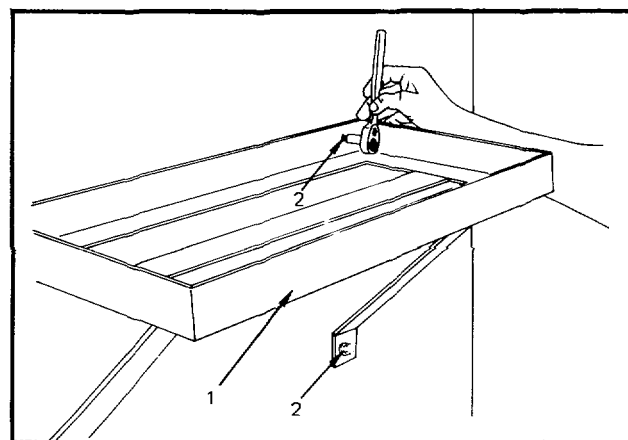

3. Install new book rack (1), and perform the following.
 - a. Paint; one coat primer and two coats enamel before installing.
(Use primer, item 5, and enamel, item 4, App D.)
 - b. Position rack (1), align holes in rack (3) with wall inserts.

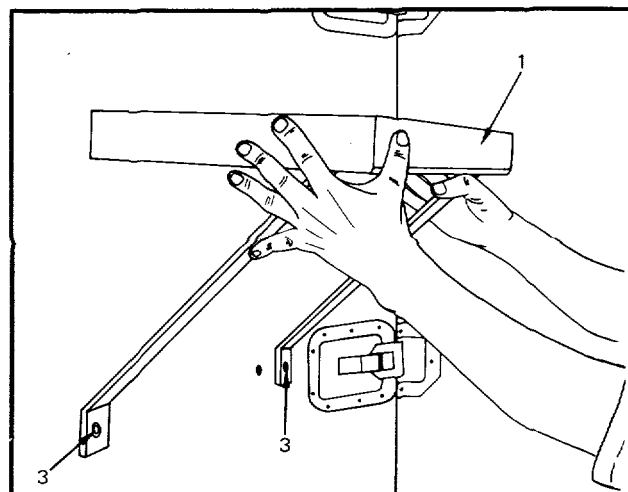

GO TO NEXT PAGE

3-18. Special Brackets and Fabricated Components Book Rack - Replace (Cont)

3-18

4. Install bolts (2) in book rack (1) with washers (4).

END OF TASK

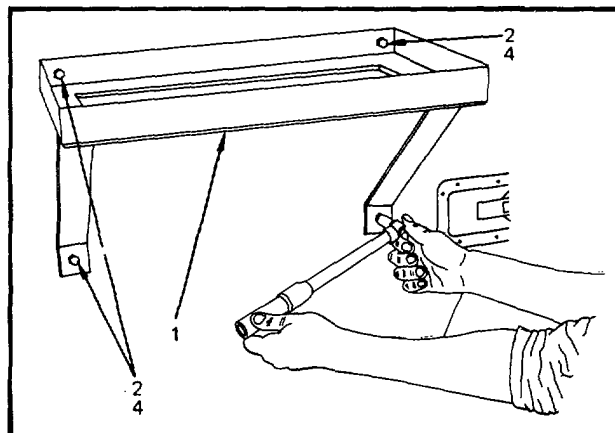

3-19. Floor Insert Fasteners and Plugs - Inspect

3-19

This task covers: Inspection of floor insert plugs

INITIAL SETUP

Tools:

Tool Kit, Electrical Repairer, Army Aircraft,
NSN 5180-00-323-4915

Personnel Required:

68F Aircraft Electrician

INSPECTION

NOTE

Go to step 2 if plugs are serviceable.

1. Inspect floor plugs.

a. Remove any floor plug (1) that will not screw into floor insert (2).

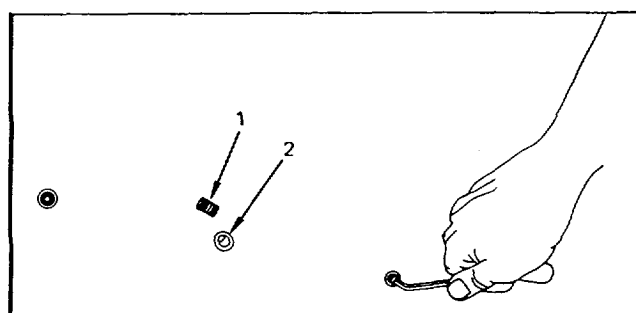

b. Inspect plug (1) for damaged threads.

c. Install new plug (1) as required.

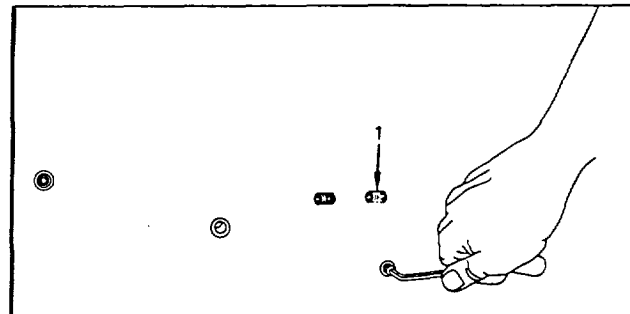

2. Inspect floor inserts when plugs are not damaged.

a. Visually inspect floor inserts (2) with flashlight (3).

b. If insert threads are damaged or insert has broken loose in adhesive potting, replace. See TASK 3-7.

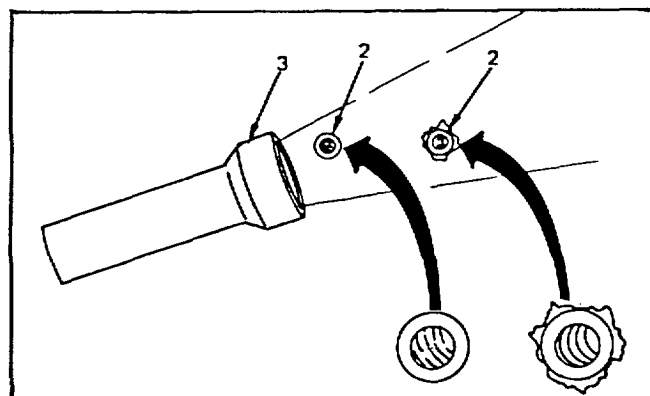

END OF TASK

3-20. Fixed Equipment/Components - Removal/Installation**3-20**

This task covers: Removal/installation of fixed, equipment/components

INITIAL SETUPTools:

Tool Kit, Electrical Repairer, Army Aircraft, NSN 5180-00-323-4915

Personnel Required:

68F Aircraft Electrician

REMOVAL/INSTALLATION**NOTE**

Permanently installed equipment or components should not be removed, however, in the event it becomes necessary to remove, reinstall or replace fixed equipment or shop components within the shelter care must be taken to remove all bolts, nuts and other fasteners. All cabinets and racks are bolted to the floor and unless isolated, are normally bolted to adjacent cabinets and/or to the wall and ceilings.

1. Remove bolts (1) nuts and washers (2).
2. During reinstallation of fixed equipment or components the same hardware should be used so as to maintain the original integrity of the shop sets. This is especially critical in regard to items bolted to walls or ceilings.

END OF TASK

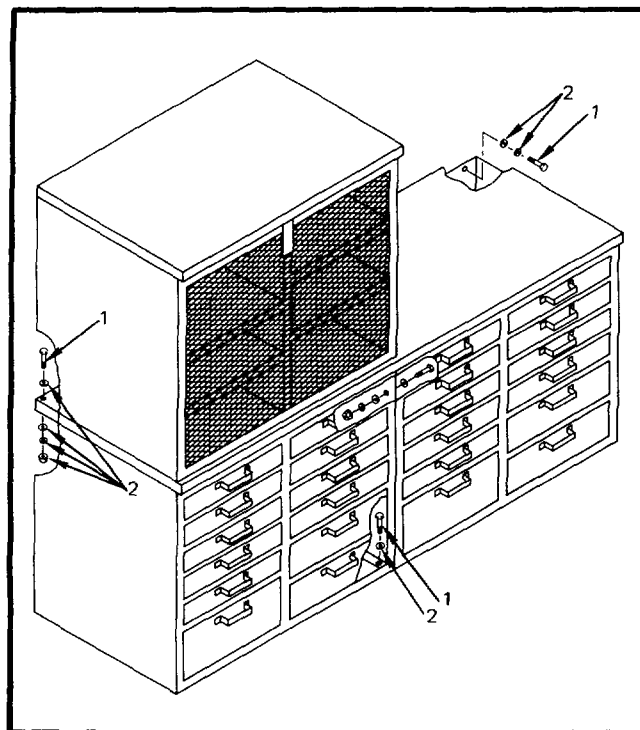

**APPENDIX A
REFERENCES**

A-1. Dictionaries of Terms and Abbreviations.

AR 310-25.....Dictionary of United States Army Terms
AR 310-50.....Authorized Abbreviations and Brevity Codes

A-2. Publication Indexes.

DA PAM 25-30.....Consolidated Index of Army Publications and Blank Forms

A-3. Logistics and Storage.

TM 743-200-1.....Storage and Materiel Handling

A-4. Maintenance of Supplies and Equipment.

AR 750-1.....Army Materiel Maintenance Concepts and Policies
TM 5-4120-369-14Air Conditioner, Horizontal, Compact, 18,000 BTU
TM 10-5411-201-14Shelter, Tactical, Expandable, One Side NSN 5411-01-124-1377

TM 43-0139.....Painting Operations Instructions for Field Use
TM 55-1500-204-25/1.....General Aircraft Maintenance Manual

A-5. Other Publications.

AR 420-90.....Fire Prevention and Protection
AR 55-38.....Reporting of Transportation Discrepancies in Shipments
AR 700-58.....Packaging Improvement Report
DA PAM 310-13.....Military Publications Posing and Filing
DA PAM 738-751.....Functional Users Manual for the Army Maintenance Management System (TAMMS-A)
FM 21-11.....First Aid for Soldiers
MIL-W-8604AWelding, Fusion, Aluminum Alloy Process and Performance
TC 11-6.....Grounding Techniques
TB 43-180Calibration Requirements for the Maintenance Army Materiel
TM 750-244-1-4.....Procedures for the Destruction of Aviation Ground Support Equipment (FSC 4920) to Prevent Enemy Use

**APPENDIX B
MAINTENANCE ALLOCATION CHART**

SECTION I. INTRODUCTION

B-1. General.

- a. This section provides a general explanation of all maintenance and repair functions authorized AVIM personnel.
- b. The Maintenance Allocation Chart (MAC) in Section II designates overall authority and responsibility for the performance of maintenance functions on the Electric/Instrument Shop. The application of the maintenance function to the end item or component will be consistent with the capacities and capabilities of the designated maintenance categories.
- c. Section III lists the tools and test equipment required for each maintenance function as referenced from Section II.
- d. Section IV contains supplemental instructions and explanatory notes for a particular maintenance function.

B-2. Maintenance Functions. Maintenance Functions will be limited to and defined as follows:

- a. Inspect. To determine the serviceability of an item by comparing its physical and mechanical characteristics with established standards through examination (e.g., by sight, sound, or feel).
- b. Removal/Install. To remove and install the same item when required to perform service or other maintenance functions. Install may be the act of emplacing, seating, or fixing into position a spare, repair part, or module (component or assembly) in a manner to allow the proper functioning of an equipment or system.
- c. Replace. To remove an unserviceable item and install a serviceable counterpart in its place. "Replace" is authorized by the MAC and is shown as the 3d position code of the SMR code.
- d. Repair. The application of maintenance services, including fault location/troubleshooting, removal/installation, and disassembly/assembly procedures, and maintenance actions to identify troubles and restore serviceability to an item by correcting specific damage, fault, malfunction, or failure in a part, subassembly, or end item.

B-3. Explanation of Columns in the MAC, Section II.

- a. Column 1, Group Number. Column 1 lists functional group code numbers, the purpose of which is to identify maintenance of significant components, assemblies, and subassemblies, with the next higher assembly. End item group number is "00".
- b. Column 2, Component/Assembly. Column 2 contains the names of components, assemblies, and subassemblies for which maintenance is authorized.
- c. Column 3, Maintenance Function. Column 3 lists functions to be performed on the item listed in Column 2. (For detailed explanation of these functions, see paragraph B-2.)

d. Column 4, Maintenance Category. Column 4 specifies, by the listing of a work time figure (hours) in the appropriate subcolumn(s), the category of maintenance authorized to perform the function listed in Column 3. This figure represents the active time required to perform that maintenance function at the indicated category of maintenance. The work time figure represents the average time required to restore an item (assembly, subassembly, component, or end item) to a serviceable condition under typical field operating conditions.

e. Column 5, Tools and Equipment. Column 5 specifies, by code, those common tool sets (not individual tools) and special tools, TMDE, and support equipment required to perform the designated function.

f. Column 6, Remarks. This column, when applicable, contains a letter code, in alphabetic order, which is keyed to the remarks contained in Section IV.

B-4. Explanation of Columns in Tools and Test Equipment Requirements, Section III.

a. Column 1, Reference Code. The tool and test equipment reference code correlates with a code used in the MAC, Section II, Column 5.

b. Column 2, Maintenance Category. The lowest category of maintenance authorized to use the tool.

c. Column 3, Nomenclature. Name or identification of the tool.

d. Column 4, National Stock Number. The National Stock Number of the tool.

B-5. Explanation of Columns in Remarks, Section IV.

a. Column 1, Reference Code. The code recorded in Column 6, Section II.

b. Column 2, Remarks. This column lists information pertinent to the maintenance function being performed as indicated in the MAC, Section II.

**SECTION II. MAINTENANCE ALLOCATION CHART
FOR ELECTRIC/INSTRUMENT SHOP**

(1) GROUP NUMBER	(2) COMPONENT/ ASSEMBLY	(3) MAINTENANCE FUNCTION	(4) MAINTENANCE CATEGORY			(5) TOOLS AND EQPT	(6) REMARKS
			AVUM	AVIM	DEPOT		
01	Insert Fasteners and Bolts	INSPECT REPLACE		.2 1.5		101 103	A, B & C D
02	Fixtures						
0201	Fire Extinguisher	REMOVE INSTALL		.1 .1			
020101	Fire Extinguisher Mounting	INSPECT		.1		101	A
0202	Water/Oil Separator Mounting	INSPECT		.1		101	B
020201	Water/Oil Separator Air Hose and Fittings	INSPECT REPLACE		.1 1.0		103 103	
0203	Water Feed Thru Connector	INSPECT REPLACE		.2 1.0		103	
03	Electrical						
0301	Ground Rod/Strap	INSPECT		.2		103	
04	Special Brackets and Fabricated Components						
0401	Book Rack Mounting	INSPECT REPAIR REPLACE		.1 1.0 .5		101 102 & 103 101 & 103	
0402	Tool Box Mounting (6 unit)	INSPECT REPAIR REPLACE		.6 3.0 1.0		101 102 & 103 101 & 103	

**SECTION II. MAINTENANCE ALLOCATION CHART
FOR ELECTRIC/INSTRUMENT SHOP (Cont)**

(1) GROUP NUMBER	(2) COMPONENT/ ASSEMBLY	(3) MAINTENANCE FUNCTION	(4) MAINTENANCE CATEGORY			(5) TOOLS AND EQPT	(6) REMARKS
			AVUM	AVIM	DEPOT		
0403	Support Frame ECU	INSPECT		.2		101	
		REPAIR		1.0		102 & 103	
		REPLACE		.2		101 & 103	
0404	Security Bars ECU	INSPECT		.2		101	
		REPAIR		1.5		102 & 103	
		REPLACE		.2		101 & 103	
0405	Bracket, Cabinet Bin Storage	INSPECT		.1		101	
		REPAIR		.5		102 & 103	
		REPLACE		.3		101 & 103	
0406	Bracket, Storage Chest	INSPECT		.2		101	
		REPAIR		1.2		102 & 103	
		REPLACE		.3		101 & 103	
0407	Bracket, Exhaust Gas Tester	INSPECT		.2		101	
		REPAIR		.7		102 & 103	
		REPLACE		.3		101 & 103	
05	Floor Inserts Plugs	INSPECT		.1		103	

SECTION III. TOOL AND TEST EQUIPMENT

(1) TOOL OR TEST EQPT REF CODE	(2) MAINTENANCE CATEGORY	(3) NOMENCLATURE	(4) NATIONAL STOCK NUMBER
101	Intermediate Level	Tool Crib Shop Set	4920-01-139-4548
102	Intermediate Level	Machine Welding Shop	4920-01-139-4533
103	Intermediate Level	Tool Kit, Electrical Repairer, Army Aircraft	5180-00-323-4915

SECTION IV. REMARKS

(1) REFERENCE CODE	(2) REMARKS
A.	Torque value on 5/16" inserts not to exceed 100-140 inch pounds.
B.	Torque value on 1/4" inserts not to exceed 50-70 inch pounds.
C.	Torque value on 3/8" inserts not to exceed 160-190 inch pounds.
D.	Follow procedures in TM 10-5411-201-14.

APPENDIX C
REPAIR PARTS AND SPECIAL TOOL LIST
(CURRENT AS OF 17 JUL 84)

SECTION I. INTRODUCTION

C-1. Scope.

This manual lists and authorizes spares and repair parts; special tools; special test, measurement, and diagnostic equipment (TMDE); and other special support equipment required for performance of Aviation Intermediate Maintenance of the Electric/Instrument Shop. It authorizes the requisitioning, issue, and disposition of spares, repair parts and special tools as indicated by the Source, Maintenance and Recoverability (SMR) codes.

C-2. General.

This Repair Parts and Special Tools List is divided into the following sections:

a. Section II. Repair Parts List. A list of spares and repair parts authorized by this RPSTL for use in the performance of maintenance. The list also includes parts which must be removed for replacement of the authorized parts. Parts lists are composed of functional groups in ascending numerical sequence, with the parts in each group listed in ascending figure and item number sequence. Bulk materials are listed in NSN sequence.

b. Section III. Special Tools List. A list of special tools, special TMDE, and other special support equipment authorized by this RPSTL for the performance of maintenance.

c. Section IV. National Stock Number and Part Number Index. A list, in National item identification number (NIIN) sequence, of all National stock numbers (NSN) appearing in the listings, followed by a list in alphanumeric sequence of all part numbers appearing in the listings. National stock numbers and part numbers are cross-referenced to each illustration figure and item number appearance.

C-3. Explanation of Columns.

a. Column 1, ILLUSTRATION. Column 1 is divided as follows:

- (1) ((a) FIG NO.) Figure Number. Indicates the figure number illustrating an exploded view of a functional group.
- (2) ((b) ITEM NO.) Indicates the number used to identify items called out in the illustration.

b. Column 2, SMR CODE. Column 2, the Source, Maintenance, and Recoverability (SMR) code is a 5-position code containing supply/requisitioning information, maintenance category authorization criteria, and disposition instructions, as shown in the following breakout:

Source Code	Maintenance Code	Recoverability Code
1st XX two positions	XX	5th position X
How you get an item	3d position Who can install, replace or use the item	4th position Who can do complete repair* on the item
		Who determines disposition action on an unserviceable item

*Complete Repair: Maintenance capacity, capability, and authority to perform all the corrective maintenance tasks of the "Repair" function in a use/user environment in order to restore serviceability to a failed item.

(1) Source Code. The source code tells you how you get an item needed for maintenance, repair, or overhaul of an end item/equipment. Source codes are always the first two positions of the SMR code. Explanations of source codes follow:

Code	Explanation
PA PB PC PD PE PF PG	Stocked items; use the applicable NSN to request/requisition items with these source codes. They are authorized to the category indicated by the code entered in the 3d position of the SMR code.

KD KF KB	Items with these codes are not to be requested/requisitioned individually. They are part of a kit which is authorized to the maintenance category indicated in the 3d position of the SMR code. The complete kit must be requisitioned and applied.

MO - (Made at org/ AVUM Category) MF - (Made at DS/ AVIM Category) MH - (Made at GS Category) MD - (Made at Depot)	Items with these codes are not to be requested/requisitioned individually. They must be made from bulk material which is identified by NSN in the Description column and listed in the Bulk Materiel group in the repair parts list in this manual. If the item is authorized to you by the 3d position code of the SMR code, but the source code indicates it is made at a higher category, order the item from the higher category of maintenance.

Code	Explanation
AO - (Assembled by org/AVUM Category)	Items with these codes are not to be requested/requisitioned individually. The parts that make up the assembled item must be requisitioned or fabricated and assembled at the category of maintenance indicated by the source code. If the 3d position code of the SMR code authorizes you to replace the item, but the source code indicates the item is assembled at a higher category, order the item from the higher category of maintenance.
AF - (Assembled by (DS/AVIM Category)	
AH - (Assembled by GS Category)	
AD - (Assembled by Depot)	
XA -	Do not requisition an "XA"-coded item. Order its next higher assembly. (Also, refer to the NOTE below.)
XB -	If an "XB" item is not available from salvage, order it using the FSCM and part number given.
XC -	Installation drawing, diagram, instruction sheet, field service drawing, that is identified by manufacturer's part number.
XD -	Item is not stocked. Order an "XD"-coded item through normal supply channels using the FSCM and part number given, if no NSN is available.

NOTE

Cannibalization or controlled exchange, when authorized, may be used as a source of supply for items with the above source codes, except for those source coded "XA" or those aircraft support items restricted by requirements of AR 700-42.

(2) Maintenance Code. Maintenance codes tell you the category(s) of maintenance authorized to USE and REPAIR support items. The maintenance codes are entered in the third and fourth positions of the SMR Code as follows:

(a) The maintenance code entered in the third position tells you the lowest maintenance category authorized to remove, replace, and use an item. The maintenance code entered in the third position will indicate authorization to one of the following categories of maintenance.

Code	Application/Explanation
C	- Crew or operator maintenance done within organizational or aviation unit maintenance.
O	- Organizational or aviation unit category can remove, replace, and use the item.
F	- Direct support or aviation intermediate category can remove, replace, and use the item.
H	- General support category can remove, replace, and use the item.

Code	Application/Explanation
L	- Specialized repair activity can remove, replace, and use the item.
D	- Depot category can remove, replace, and use the item.

(b) The maintenance code entered in the fourth position tells you whether or not the item is to be repaired and identifies the lowest maintenance category with the capability to do complete repair (i.e., perform all authorized repair functions). **(NOTE: Some limited repair may be done on the item at a lower category of maintenance, if authorized by the Maintenance Allocation Chart (MAC) and SMR codes.)** This position will contain one of the following maintenance codes.

Code	Application/Explanation
O	- Organizational or aviation unit is the lowest category that can do complete repair of the item.
F	- Direct support or aviation intermediate is the lowest category that can do complete repair of the item.
H	- General support is the lowest category that can do complete repair of the item.
L	- Specialized repair activity (designate the specialized repair activity) is the lowest category that can do complete repair of the item.
D	- Depot is the lowest category that can do complete repair of the item.
Z	- Nonreparable. No repair is authorized.
B	- No repair is authorized. (No parts or special tools are authorized for the maintenance of a "B" coded item.) However, the item may be reconditioned by adjusting, lubricating, etc., at the user level.

(3) Recoverability Code. Recoverability codes are assigned to items to indicate the disposition action on unserviceable items. The recoverability code is entered in the fifth position of the SMR Code as follows:

Recoverability Codes	Definition
Z	- Nonreparable item. When unserviceable, condemn and dispose of the item at the category of maintenance shown in 3d position of SMR Code.
O	- Repairable item. When uneconomically repairable, condemn and dispose of the item at organizational or aviation unit category.

Recoverability Codes	Definition
F	- Reparable item. When uneconomically reparable, condemn and dispose of the item at the direct support or aviation intermediate category.
H	- Reparable item. When uneconomically reparable, condemn and dispose of the item at the general support category.
D	- Reparable item. When beyond lower category repair capability, return to depot. Condemnation and disposal of item not authorized below depot category.
L	- Reparable item. Condemnation and disposal not authorized below specialized repair activity.
A	- Item requires special handling or condemnation procedures because of specific reasons (i.e., precious metal content, high dollar value, critical materiel, or hazardous materiel). Refer to appropriate manuals/directives for specific instructions.

c. Column 3, NATIONAL STOCK NUMBER. Column 3 lists the National stock number (NSN) assigned to the item. Use the NSN for requests/requisitions.

d. Column 4, FSCM, Column 4, the Federal Supply Code for Manufacturer (FSCM) is a 5-digit numeric code which is used to identify the manufacturer, distributor, or Government agency, etc., that supplies the item.

e. Column 5, PART NUMBER. Column 5 indicates the primary number used by the manufacturer (individual, company, firm, corporation, or Government activity), which controls the design and characteristics of the item by means of its engineering drawings, specifications standards, and inspection requirements to identify an item or range of items.

NOTE

When you use an NSN to requisition an item, the item you receive may have a different part number from the part ordered, but go ahead and use or furnish it as the replacement part.

f. Column 6, DESCRIPTION. Column 6 includes the following information:

(1) The Federal item name and, when required, a minimum description to identify the item.

(2) The physical security classification of the item is indicated by the parenthetical entry (insert applicable physical security classification abbreviation, e.g., Phy Sec C1 (C) - Confidential, Phy Sec C1 Secret, Phy Sec C1 (T) - Top Secret).

(3) Items are included in kits and sets are listed below the name of the kit or set.

(4) Spare/repair parts that make up an assembled item are listed immediately following the assembled item line entry.

(5) NSN's for bulk materials are referenced in the description column in the line item entry for the item to be manufactured/fabricated.

(6) When the part to be used differs between serial numbers of the same model, the effective serial numbers are shown as the last line of the description.

(7) The USABLE ON CODE, when applicable (see paragraph 4, Special Information).

(8) In the Special Tools List section, the basis of issue (BOI) appears as the last line(s) in the entry for each special tool, special TMDE, and other special support equipment. When density of equipments supported exceeds density spread indicated in the basis of issue, the total authorization is increased proportionately.

g. Column 7, U/M. Column 7, Unit of Measure (U/M) indicates the measure (e.g., foot, gallon, pound) or count (e.g., each, dozen, gross) of a listed item. A two-character alpha code (e.g., FT, GL, LB, EA, DZ, GR) appears in this column to indicate the measure or count. If the U/M code appearing in this column differs from the Unit of Issue (U/I) code listed in the Army Master Data File (AMDF), request the lowest U/I that will satisfy your needs.

h. Column 8, QTY INC IN UNIT. Column 8, Quantity Incorporated in Unit (QTY INC IN UNIT) indicates the quantity of the item used in the breakout shown on the illustration figure, which is prepared for a functional group, subfunctional group, or an assembly. A "V" appearing in this column in lieu of a quantity indicates that no specific quantity is applicable (e.g., shims, spacers).

C-4. How to Locate Repair Parts.

a. When National Stock Number or Part Number is Not Known:

(1) First. Using the table of contents, determine the functional group or subfunctional group to which the item belongs. This is necessary since figures are prepared for functional groups and subfunctional groups, and listings are divided into the same groups.

(2) Second. Find the figure covering the functional group or subfunctional group to which the item belongs.

(3) Third. Identify the item on the figure and note the item number of the item.

(4) Fourth. Refer to the Repair Parts List for the figure to find the line item entry for the item number noted on the figure.

b. When National Stock Number or Part Number is Known:

(1) First. Using the Index of National Stock Numbers and Part Numbers, find the pertinent National stock number or part number. The NSN index is in National Item Identification Number (NIIN)* sequence. The part numbers in the Part Number index are listed in ascending alphanumeric sequence. Both indexes cross-reference you to the illustration figure and item number of the item you are looking for.

NSN

*The NIIN consists of the last 9 digits of the NSN (i.e., 5305-01-674-1467).

NIIN

(2) Second. After finding the figure and item number, verify that the item is the one you're looking for, then locate the item number in the repair parts list for the figure.

C-5. Abbreviations. Not Applicable.

SECTION II. REPAIR PARTS LIST

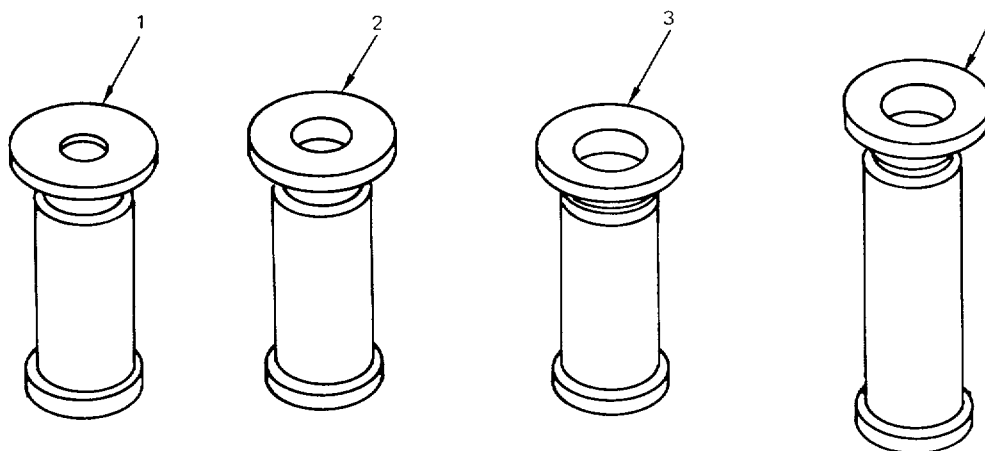

Figure C-1. Insert Fasteners

(1) ILLUSTRATION		(2) SMR CODE	(3) NATIONAL STOCK NUMBER	(4) FSCM	(5) PART NUMBER	(6) DESCRIPTION	(7) U/M	(8) QTY INC IN UNIT
(a) FIG NO.	(b) ITEM NO.							
C-1	1	PAFZZ		97393	SL601-4-8C	GROUP 01 INSERT FASTENERS INSERT, FASTENER TYPE 1/4".....	EA	V
C-1	2	PAFZZ		97393	SL601-5-10C	INSERT, FASTENER TYPE 5/18".....	EA	V
C-1	3	PAFZZ		97393	SL601-6-8C	INSERT, FASTENER TYPE 3/8 x 1.....	EA	V
C-1	4	PAFZZ	5340-00-044-5270	97393	SL601-6-12C	INSERT, FASTENER TYPE 3/8 x 1 1/2.....	EA	V

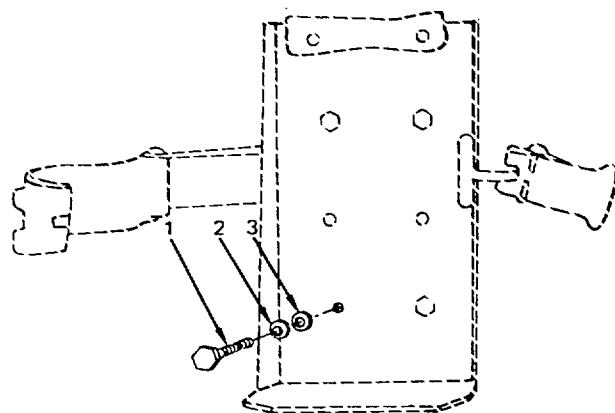

Figure C-2. Fire Extinguisher Mounting

(1) ILLUSTRATION		(2)	(3)	(4)	(5)	(6)	(7)	(8)
(a) FIG NO.	(b) ITEM NO.	SMR CODE	NATIONAL STOCK NUMBER	FSCM	PART NUMBER	DESCRIPTION	U/M	QTY INC IN UNIT
						GROUP 02 FIXTURES SUBGROUP 020101 FIRE EXTINGUISHER MOUNTING		
C-2	1	PAFZZ	5306-00-150-9104	88044	AN5-5A	BOLT, MACHINE.....	EA	4
C-2	2	PAFZZ	5310-00-407-9566	88044	AN935-516	WASHER, LOCK	EA	4
C-2	3	PAFZZ	5310-00-187-2399	88044	AN960-PD-516	WASHER, FLAT.....	EA	4

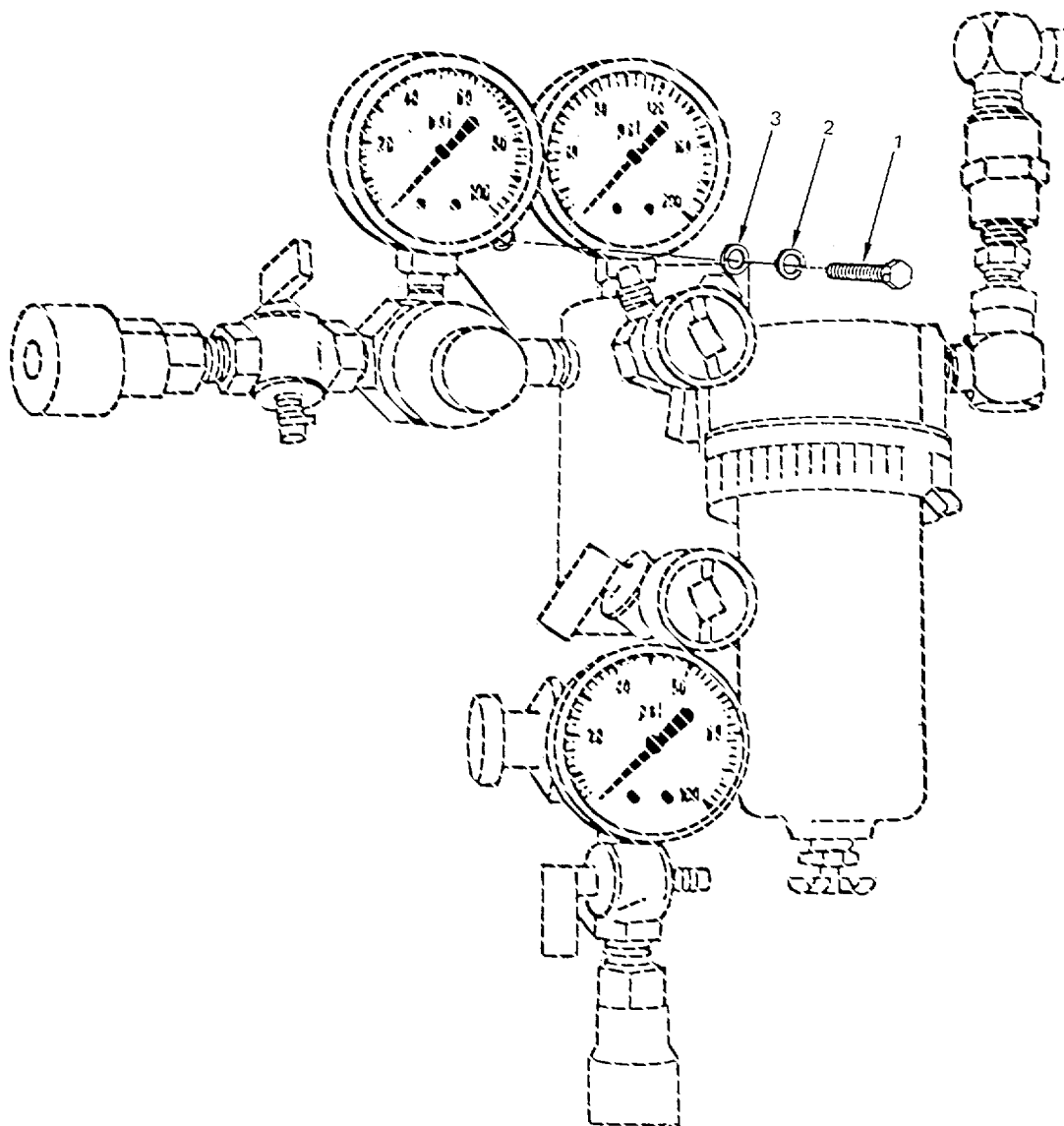

Figure C-3. Water/Oil Separator Mounting

(1) ILLUSTRATION		(2)	(3)	(4)	(5)	(6)	(7)	(8)
(a) FIG NO.	(b) ITEM NO.	SMR CODE	NATIONAL STOCK NUMBER	FSCM	PART NUMBER	DESCRIPTION	U/M	QTY INC IN UNIT
C-3	1	PAFZZ	5306-00-151-1427	88044	AN4-5A	GROUP 02 FIXTURES SUBGROUP 0202 WATER/OIL SEPARATOR MOUNTING	EA	2
C-3	2	PAFZZ	5310-00-582-5965	88044	AN935-416	BOLT, MACHINE.....	EA	2
C-3	3	PAFZZ	5310-00-187-2354	88044	AN960-PD-416	WASHER, LOCK..... WASHER, FLAT.....	EA	2

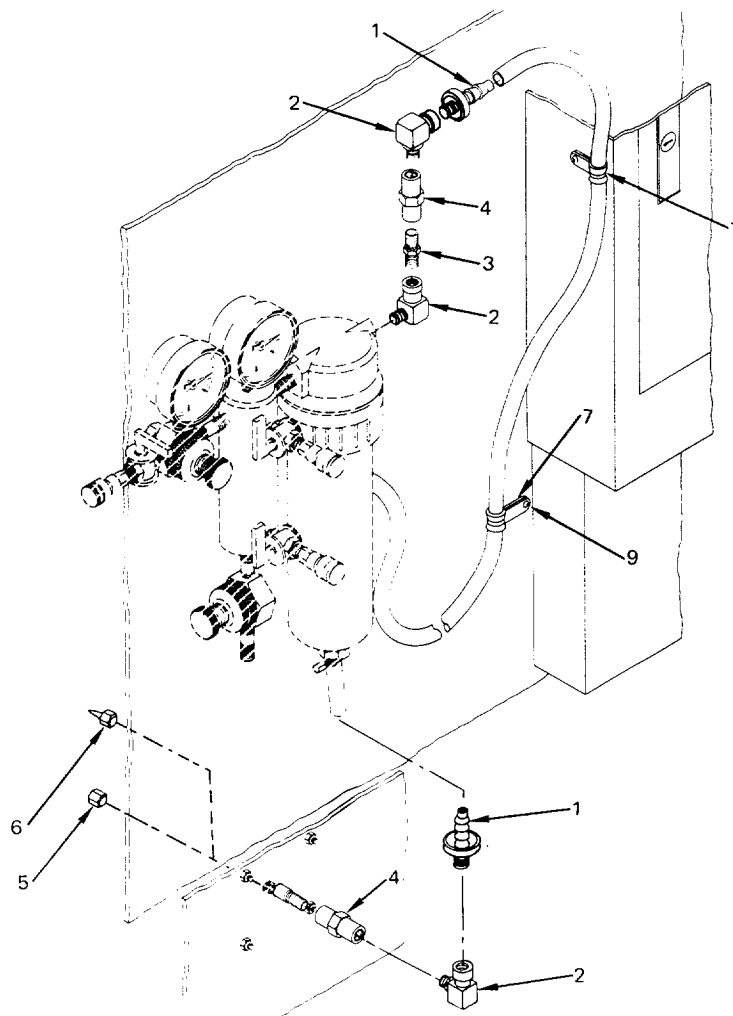

Figure C-4. Water/Oil Separator Air Hose and Fittings

(1) ILLUSTRATION		(2)	(3)	(4)	(5)	(6)	(7)	(8)
(a) FIG NO.	(b) ITEM NO.	SMR CODE	NATIONAL STOCK NUMBER	FSCM	PART NUMBER	DESCRIPTION	U/M	QTY INC IN UNIT
						GROUP 02 FIXTURES SUBGROUP 020201 WATER/OIL SEPARATOR AIR HOSE ASSY AND FITTINGS		
C-4	1	PAFZZ	4730-00-932-7511	00624	4738-4-6	FITTING, HOSE.....	EA	2
C-4	2	PAFZZ	4730-00-595-0385	79470	C3409X4	ELBOW, PIPE.....	EA	3
C-4	3	PAFZZ	4730-00-288-6997	03958	896WM	NIPPLE, PIPE.....	EA	1
C-4	4	PAFZZ	4730-00-541-8286	88044	AN9102C	COUPLING, PIPE.....	EA	2
C-4	5	PAFZZ	4730-00-203-3168	81348	WW-P-521	CAP, PIPE.....	EA	1
C-4	6	PAFZZ	4730-00-142-1960	14127	SHD11	COUPLING, HALF QUICK	EA	1
C-4	7	PAFZZ	5340-00-565-0004	88044	AN742-12CB	CLAMP, LOOP.....	EA	2
C-4	8	PAFZZ				HOSE, NON-METALLIC (SEE GROUP 99).....		
C-4	9	PAFZZ				USE EXISTING SCREW AND WASHERS.....		

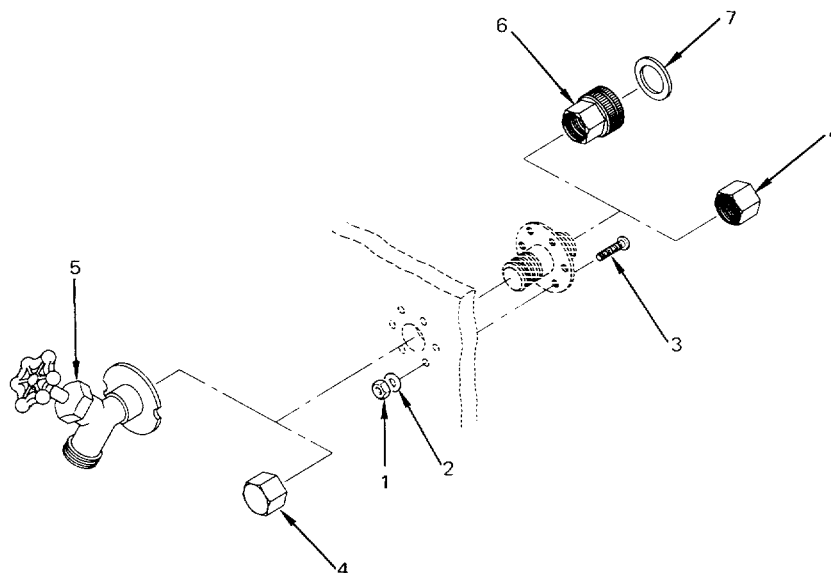

Figure C-5. Water Feed Thru Connector

(1) ILLUSTRATION		(2)	(3)	(4)	(5)	(6)	(7)	(8)
(a) FIG NO.	(b) ITEM NO.	SMR CODE	NATIONAL STOCK NUMBER	FSCM	PART NUMBER	DESCRIPTION	U/M	QTY INC IN UNIT
						GROUP 02 FIXTURES SUBGROUP 0203 WATER FEED THRU CONNECTOR SEE APPENDIX E, ILLUSTRATED LIST OF MANUFACTURED ITEMS, FOR DETAILED DRAWING		
C-5	1	PAFZZ	5310-00-934-9751	19422	BM12297-08	NUT PLAIN, HEX.....	EA	6
C-5	2	PAFZZ	5310-00-167-0834	59875	TX90790-34	WASHER, FLAT.....	EA	6
C-5	3	PAFZZ	5305-00-082-6780	28977	AA52525-24	SCREW, MACHINE.....	EA	6
C-5	4	PAFZZ	4730-00-724-1998	81348	WW-P-460	CAP, PIPE.....	EA	2
C-5	5	PAFZZ	4510-00-142-1619	58536	A-A-232	FAUCET, SINGLE.....	EA	1
C-5	6	PAFZZ	4730-00-547-0941	30938	FIG. 1620-1	ADAPTER, STRAIGHT.....	EA	1
C-5	7	PAFZZ	5310-00-599-0776		NO REF	WASHER, FLAT.....	EA	1

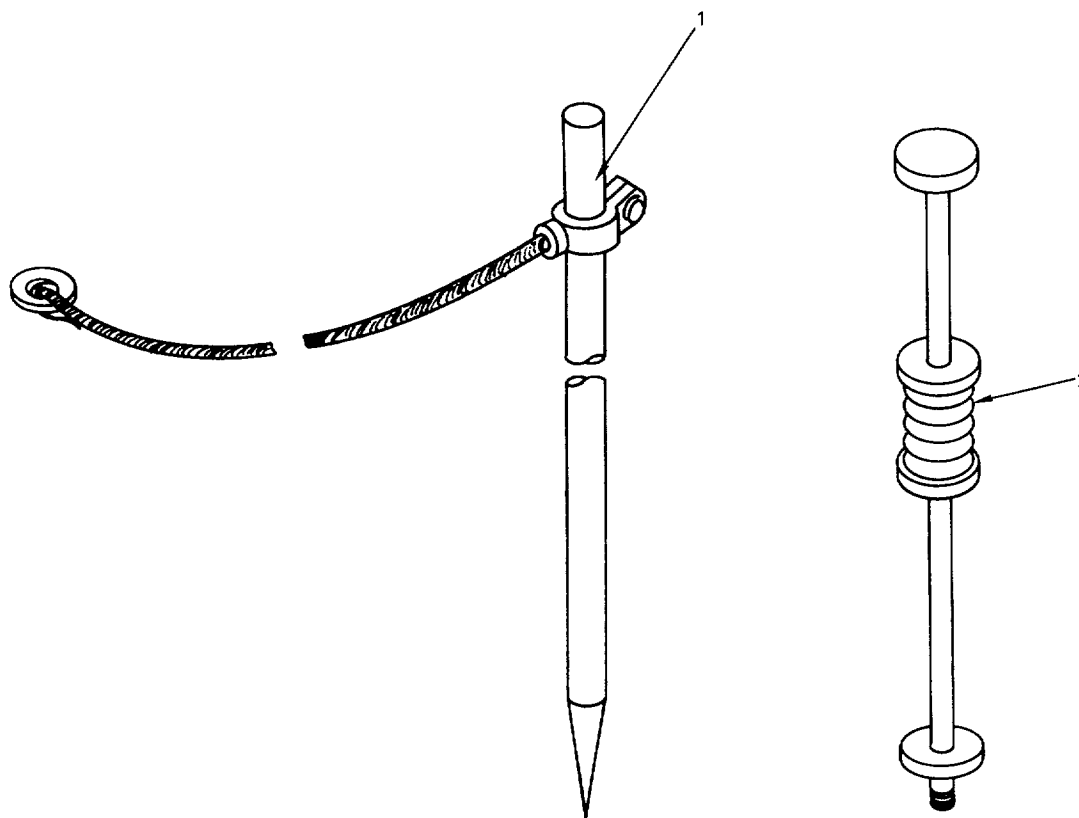

Figure C-6. Ground Rod Kit

(1) ILLUSTRATION		(2)	(3)	(4)	(5)	(6)	(7)	(8)
(a) FIG NO.	(b) ITEM NO.	SMR CODE	NATIONAL STOCK NUMBER	FSCM	PART NUMBER	DESCRIPTION	U/M	QTY INC IN UNIT
C-6	1	PAFZZ	5975-00-878-3791	81349	MIL-R-11461	GROUP 03 ELECTRICAL SUBGROUP 0301 GROUND ROD KIT		
C-6	2	PAFZZ	5120-00-013-1676	45225	P74-144	GROUND ROD/STRAP..... SLIDE HAMMER, GROUND.....	EA EA	1 1

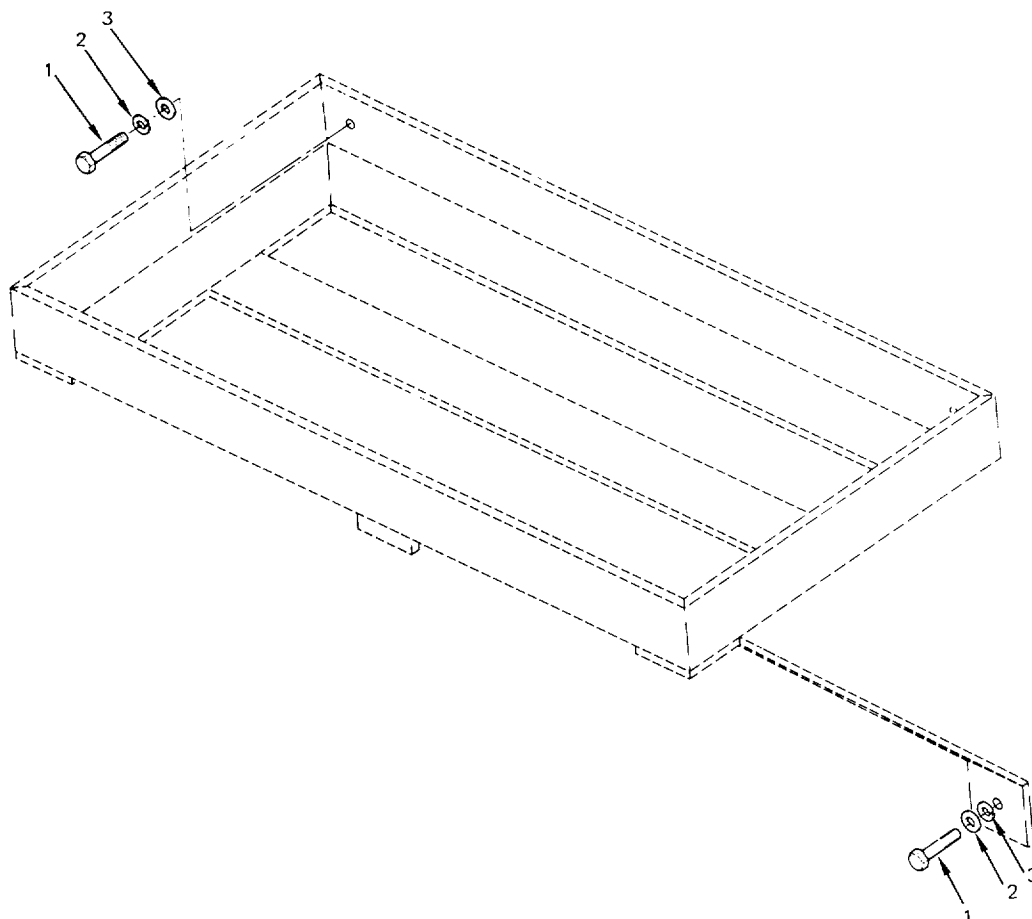

Figure C-7. Book Rack Mounting

(1) ILLUSTRATION		(2)	(3)	(4)	(5)	(6)	(7)	(8)
(a) FIG NO.	(b) ITEM NO.	SMR CODE	NATIONAL STOCK NUMBER	FSCM	PART NUMBER	DESCRIPTION	U/M	QTY INC IN UNIT
						GROUP 04 MACHINE TOOL EQUIP. SPECIAL BRACKETS AND FABRICATED COMPONENTS SUBGROUP 0401 BOOK RACK MOUNTING SEE APPENDIX E, ILLUSTRATED LIST OF MANUFACTURED ITEMS, FOR DETAILED DRAWING		
C-7	1	PAFZZ	5306-00-150-9101	88044	AN5-6A	BOLT, MACHINE.....	EA	4
C-7	2	PAFZZ	5310-00-407-9566	88044	AN935-516	WASHER, LOCK	EA	4
C-7	3	PAFZZ	5310-00-187-2399	88044	AN960-PD-516	WASHER, FLAT	EA	4

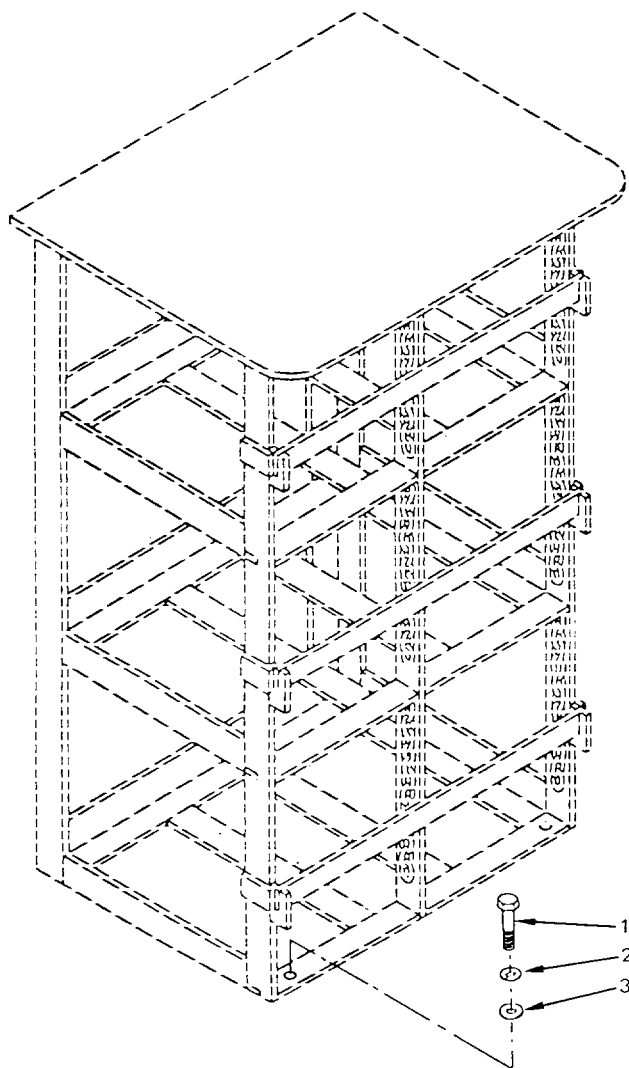

Figure C-8. Tool Box Rack Mounting (6 unit)

(1) ILLUSTRATION		(2)	(3)	(4)	(5)	(6)	(7)	(8)
(a) FIG NO.	(b) ITEM NO.	SMR CODE	NATIONAL STOCK NUMBER	FSCM	PART NUMBER	DESCRIPTION	U/M	QTY INC IN UNIT
						GROUP 04 MACHINE TOOL EQUIP. SPECIAL BRACKETS AND FABRICATED COMPONENTS SUBGROUP 0402 TOOL BOX RACK MOUNTING SEE APPENDIX E, ILLUSTRATED LIST OF MANUFACTURED ITEMS, FOR DETAILED DRAWING		
C-8	1	PAFZZ	5306-00-616-1224	88044	AN6-6A	BOLT, MACHINE.....	EA	6
C-8	2	PAFZZ	5310-00-637-9541	96906	MS35338-46	WASHER, LOCK.....	EA	6
C-8	3	PAFZZ	5310-00-187-2400	88044	AN960-PD-616	WASHER, FLAT.....	EA	6

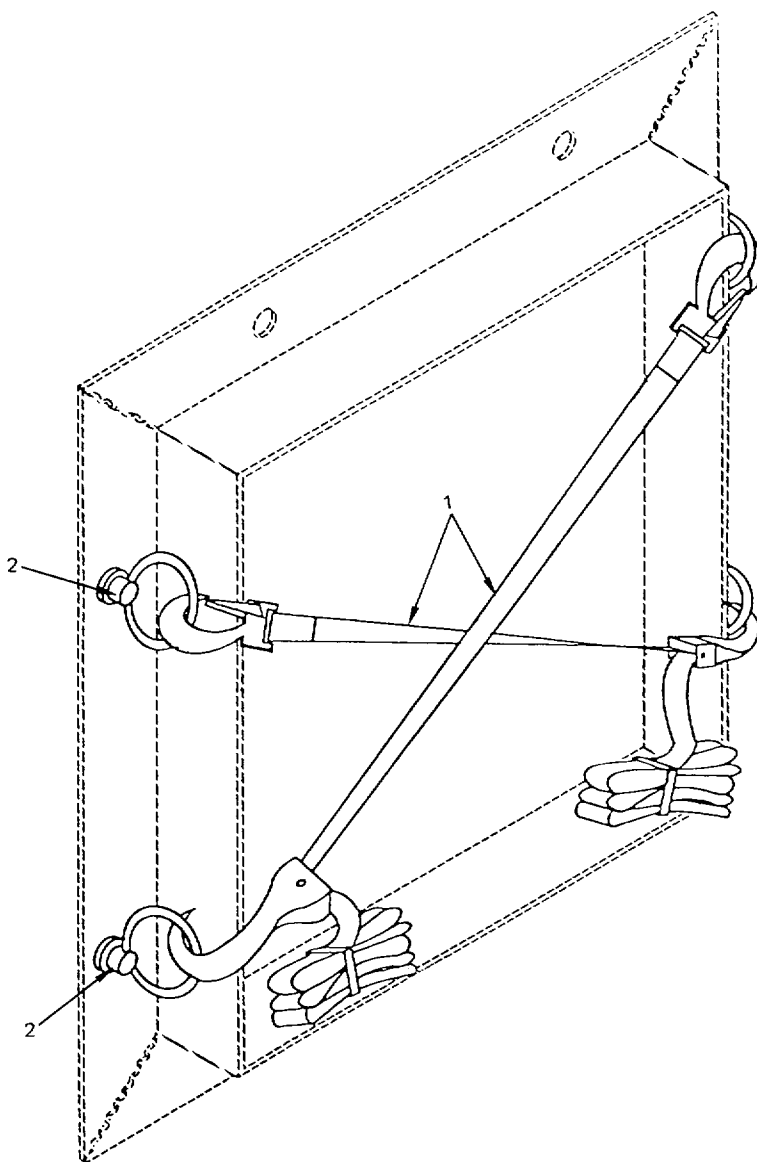

Figure C-9. Support Frame, ECU

(1) ILLUSTRATION		(2)	(3)	(4)	(5)	(6)	(7)	(8)
(a) FIG NO.	(b) ITEM NO.	SMR CODE	NATIONAL STOCK NUMBER	FSCM	PART NUMBER	DESCRIPTION	U/M	QTY INC IN UNIT
C-9	1	PAFZZ	1670-00-360-0551	81349	MIL-T-7181 TYPE A1A	GROUP 04 MACHINE TOOL EQUIP. SPECIAL BRACKETS AND FABRICATED COMPONENTS SUBGROUP 0403 SUPPORT FRAME, ECU SEE APPENDIX E, ILLUSTRATED LIST OF MANUFACTURED ITEMS, FOR DETAILED DRAWING TIE DOWN, CARGO.....	EA	4
C-9	2	PAFZZ	5306-00-624-9713	98313	FDA 1658-3	BOLT, RING.....	EA	8

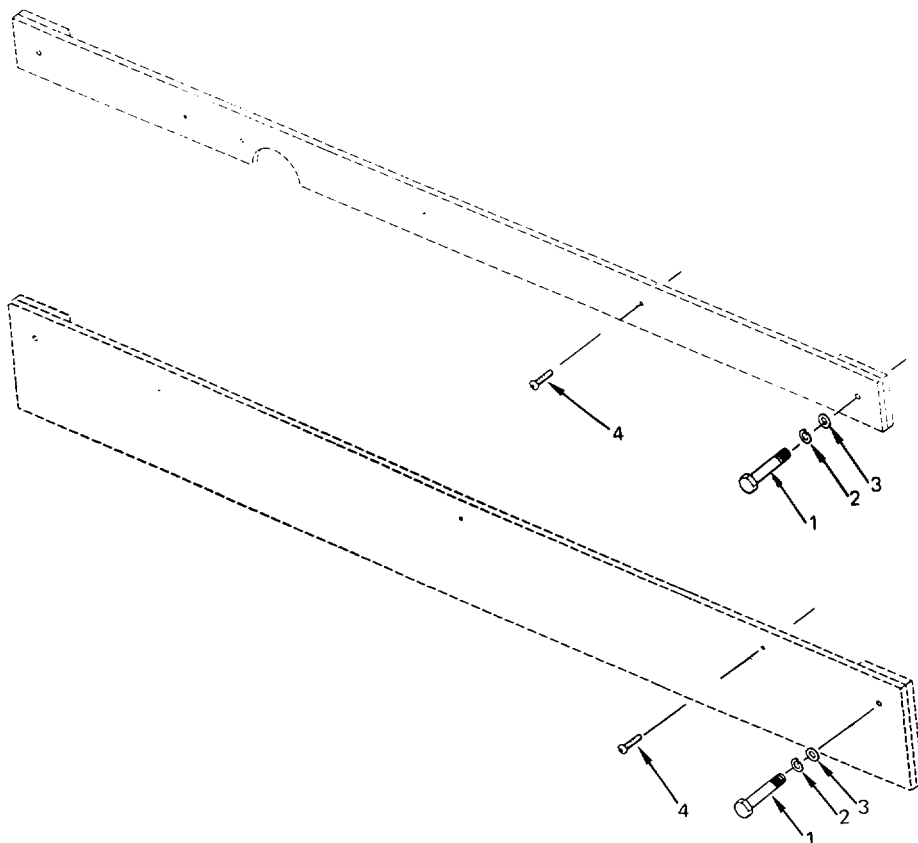

Figure C-10. Security Bars, ECU

(1) ILLUSTRATION		(2)	(3)	(4)	(5)	(6)	(7)	(8)
(a) FIG NO.	(b) ITEM NO.	SMR CODE	NATIONAL STOCK NUMBER	FSCM	PART NUMBER	DESCRIPTION	U/M	QTY INC IN UNIT
						GROUP 04 MACHINE TOOL EQUIP. SPECIAL BRACKETS AND FABRICATED COMPONENTS SUBGROUP 0404 ECU SECURITY BARS SEE APPENDIX E, ILLUSTRATED LIST OF MANUFACTURED ITEMS, FOR DETAILED DRAWINGS		
C-10	1	PAFZZ	5306-00-151-1423	88044	AN4-11A	BOLT, MACHINE.....	EA	8
C-10	2	PAFZZ	5310-00-582-5965	88044	AN935-416	WASHER, LOCK.....	EA	8
C-10	3	PAFZZ	5310-00-187-2354	88044	AN960-PD-416	WASHER, FLAT.....	EA	8
C-10	4	PAFZZ	5305-00-840-5895	96906	MS27039-0813	SCREW, MACHINE.....	EA	14

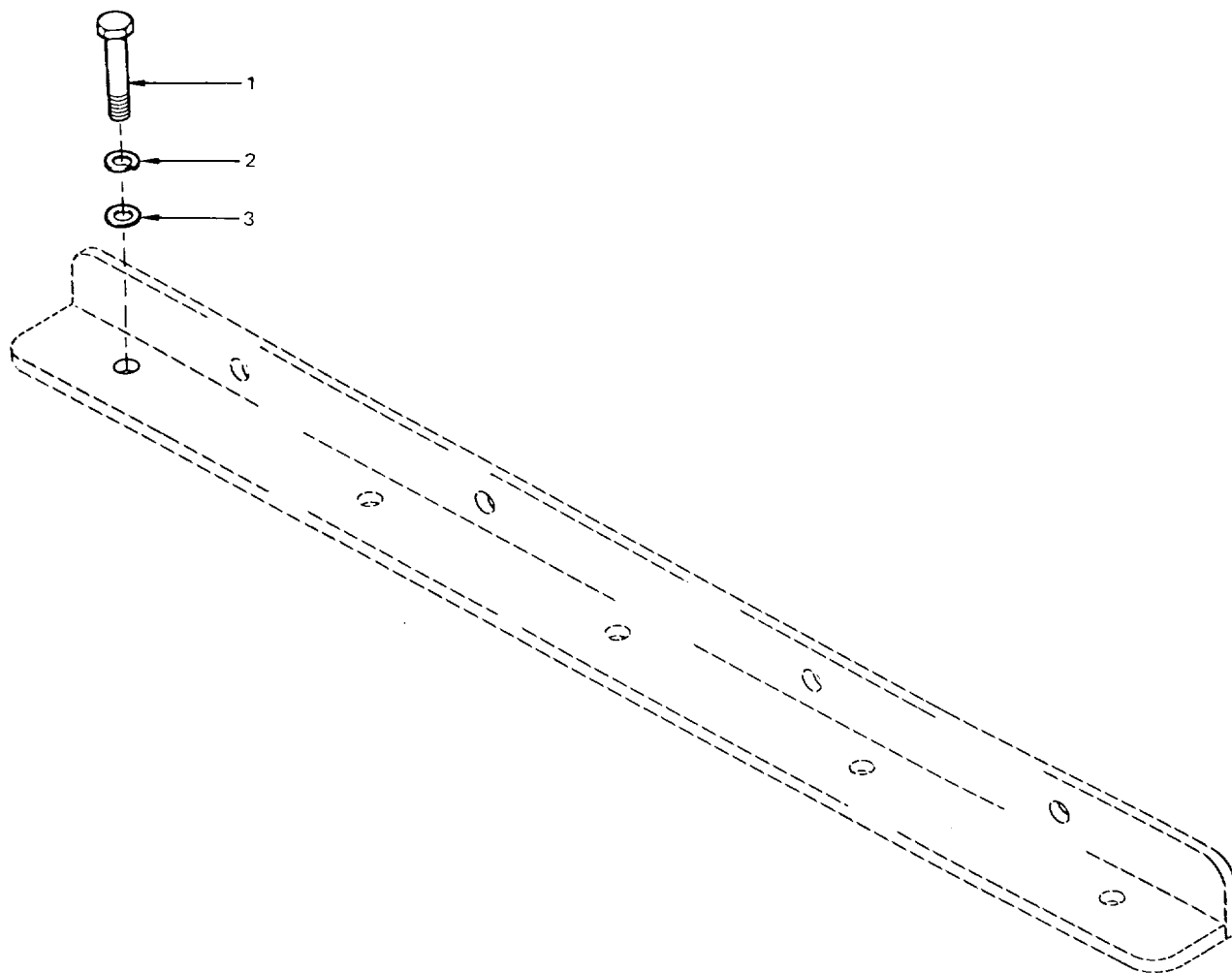

Figure C-11. Bracket, Cabinet, Bin Storage

(1) ILLUSTRATION		(2)	(3)	(4)	(5)	(6)	(7)	(8)
(a) FIG NO.	(b) ITEM NO.	SMR CODE	NATIONAL STOCK NUMBER	FSCM	PART NUMBER	DESCRIPTION	U/M	QTY INC IN UNIT
C-11	1	PAFZZ	5603-00-531-8979	88044	AN6-7A	GROUP 04 MACHINE TOOL EQUIP. SPECIAL BRACKETS AND FABRICATED COMPONENTS SUBGROUP 0405 BRACKET, CABINET, BIN STORAGE SEE APPENDIX E, ILLUSTRATED LIST OF MANUFACTURED ITEMS, FOR DETAILED DRAWING	EA	5
C-11	2	PAFZZ	5310-00-637-9541	96906	MS35338-46	BOLT, MACHINE.....	EA	5
C-11	3	PAFZZ	5310-00-187-2400	88044	AN960-PD-616	WASHER, LOCK..... WASHER, FLAT.....	EA	5

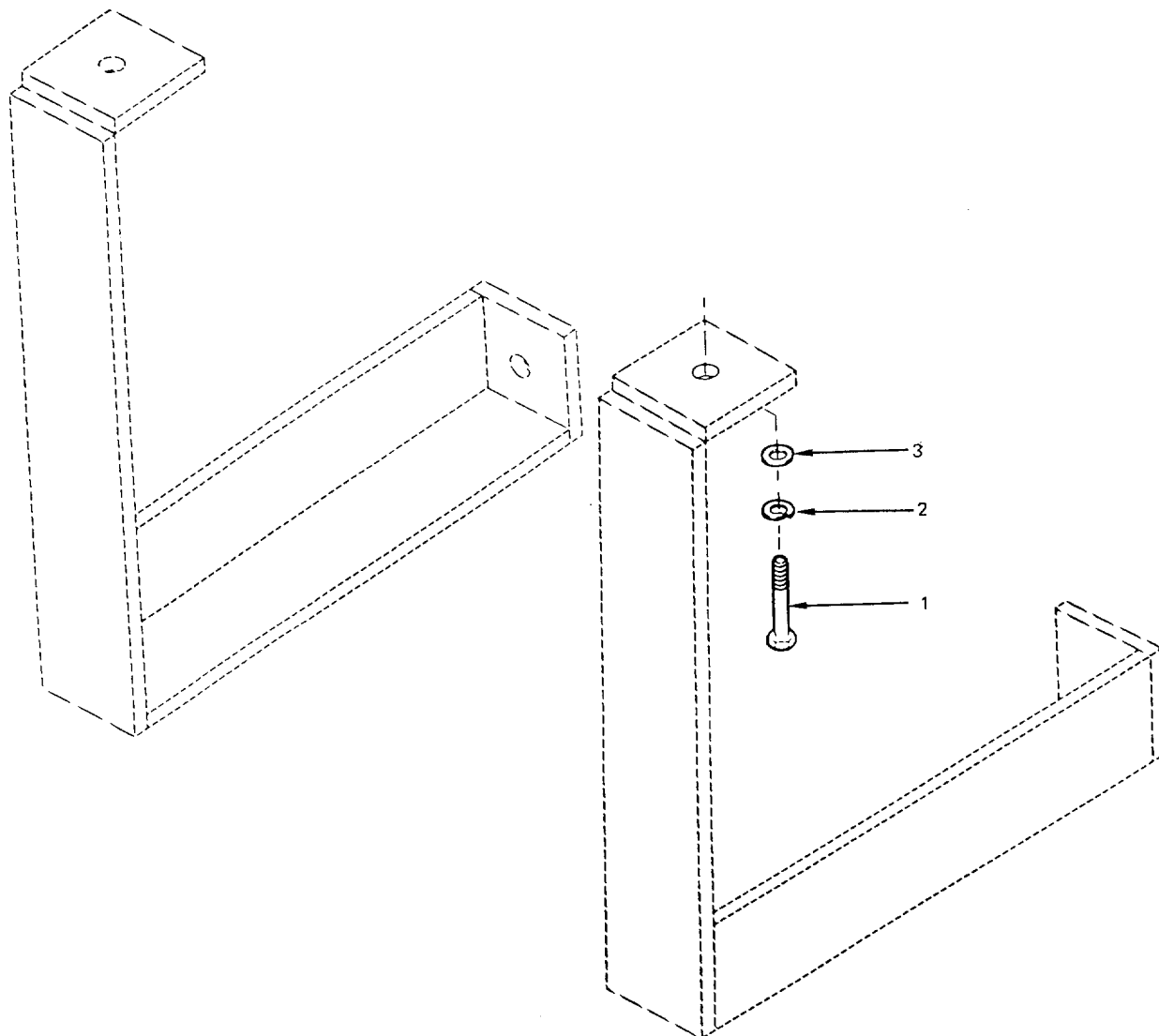

Figure C-12. Bracket, Storage Chest

(1) ILLUSTRATION		(2)	(3)	(4)	(5)	(6)	(7)	(8)
(a) FIG NO.	(b) ITEM NO.	SMR CODE	NATIONAL STOCK NUMBER	FSCM	PART NUMBER	DESCRIPTION	U/M	QTY INC IN UNIT
						GROUP 04 MACHINE TOOL EQUIP. SPECIAL BRACKETS AND FABRICATED COMPONENTS SUBGROUP 0406 BRACKET, STORAGE CHEST SEE APPENDIX E, ILLUSTRATED LIST OF MANUFACTURED ITEMS, FOR DETAILED DRAWING		
C-12	1	PAFZZ	5306-00-616-1224	88044	AN6-6A	BOLT, MACHINE.....	EA	4
C-12	2	PAFZZ	5310-00-637-9541	96906	MS35338-46	WASHER, LOCK	EA	4
C-12	3	PAFZZ	5310-00-187-2400	88044	AN960-PD-616	WASHER, FLAT.....	EA	4

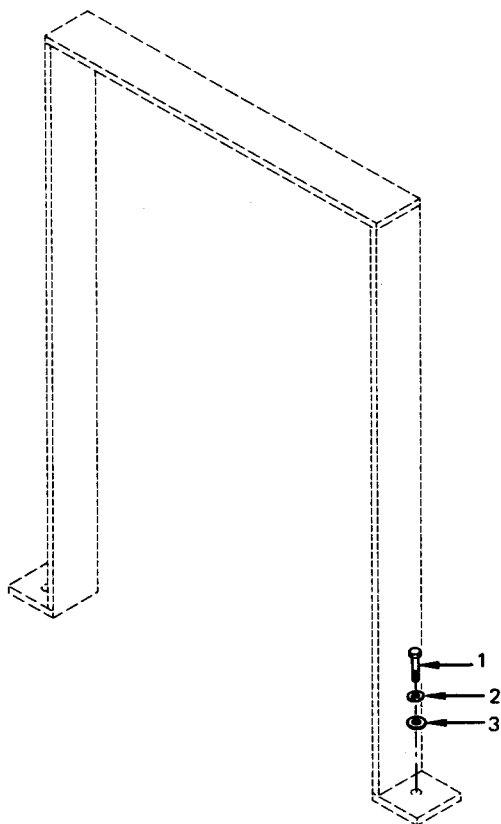

Figure C-13. Bracket, Exhaust Gas Tester

(1) ILLUSTRATION		(2)	(3)	(4)	(5)	(6)	(7)	(8)
(a) FIG NO.	(b) ITEM NO.	SMR CODE	NATIONAL STOCK NUMBER	FSCM	PART NUMBER	DESCRIPTION	U/M	QTY INC IN UNIT
						GROUP 04 MACHINE TOOL EQUIP. SPECIAL BRACKETS AND FABRICATED COMPONENTS SUBGROUP 0407 BRACKET, EXHAUST GAS TESTER SEE APPENDIX E, ILLUSTRATED LIST OF MANUFACTURED ITEMS, FOR DETAILED DRAWING		
C-13	1	PAFZZ	5306-00-616-1224	88044	AN6-6A	BOLT, MACHINE.....	EA	2
C-13	2	PAFZZ	5310-00-637-9541	96906	MS35338-46	WASHER, LOCK.....	EA	2
C-13	3	PAFZZ	5310-00-187-2400	88044	AN960-PD-616	WASHER, FLAT.....	EA	2

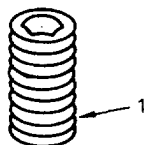

Figure C-14. Floor Insert Plugs

(1) ILLUSTRATION		(2)	(3)	(4)	(5)	(6)	(7)	(8)
(a) FIG NO.	(b) ITEM NO.	SMR CODE	NATIONAL STOCK NUMBER	FSCM	PART NUMBER	DESCRIPTION	U/M	QTY INC IN UNIT
C-14	1	PAFZZ	5305-00-728-6350	96906	MS51966-90	GROUP 05 MACHINE TOOL, EQUIP. SPECIAL BRACKETS AND STANDS SUBGROUP 0503 FLOOR INSERT PLUGS SCREW, SET 3/8".....	EA	30

(1) ILLUSTRATION		(2)	(3)	(4)	(5)	(6)	(7)	(8)
(a) FIG NO.	(b) ITEM NO.	SMR CODE	NATIONAL STOCK NUMBER	FSCM	PART NUMBER	DESCRIPTION	U/M	QTY INC IN UNIT
BULK		PAFZZ	4720-00-402-9511	05415	134MKC1	GROUP 99 BULK MATERIEL		
BULK		PAFZZ	9510-00-528-7518	81348	MIL-S-6758	HOSE ASSEMBLY	FT	V
BULK		PAFZZ	9515-00-141-8066	81346	ASTM A366	METAL BAR.....	FT	V
BULK		PAFZZ	9530-00-228-9315	81348	QQA200-8	METAL SHEET.....	SH	V
BULK		PAFZZ	9530-00-228-9316	81348	QQA250-8	METAL BAR.....	FT	V
BULK		PAFZZ	9535-00-231-8230	81348	QQA250-11	METAL BAR.....	FT	V
BULK		PAFZZ	9535-00-231-8230	81348	QQA250-11	METAL PLATE.....	SH	V
BULK		PAFZZ	9540-00-596-2776	81348	QQA200-8	STRUCTURAL ANGLE.....	FT	V
BULK		PAFZZ	9540-00-197-9846	99237	QQA200-8	STRUCTURAL ANGLE.....	FT	V
BULK		PAFZZ	9540-00-197-9850	01634	QQA200-8	STRUCTURAL ANGLE.....	FT	V

SECTION III. SPECIAL TOOLS LIST (NOT APPLICABLE)

SECTION IV. NATIONAL STOCK NUMBER AND PART NUMBER INDEX

NATIONAL STOCK NUMBER INDEX

STOCK NUMBER	FIG.	ITEM	STOCK NUMBER	FIG.	ITEM
5120-01-013-1676	C-6	2	4720-00-402-9511	BULK	
5340-00-044-5270	C-1	4	5310-00-407-9566	C-2	2
5305-00-082-6780	C-5	3	5310-00-407-9566	C-7	2
9515-00-141-8066	BULK		9510-00-528-7518	BULK	
4510-00-142-1619	C-5	5	5306-00-531-8979	C-11	1
4730-00-142-1960	C-4	6	4730-00-541-8286	C-4	4
5306-00-150-9101	C-7	1	4730-00-547-0941	C-5	6
5306-00-150-9104	C-2	1	5340-00-565-0004	C-4	7
5306-00-151-1423	C-10	1	5310-00-582-5965	C-3	2
5306-00-151-1427	C-3	1	5310-00-582-5965	C-10	2
5310-00-187-2354	C-3	3	4730-00-595-0385	C-4	2
5310-00-187-2354	C-10	3	9540-00-596-2776	BULK	
5310-00-187-2399	C-2	3	5310-00-599-0776	C-5	7
5310-00-187-2399	C-7	3	5306-00-616-1224	C-8	1
5310-00-187-2400	C-8	3	5306-00-616-1224	C-12	1
5310-00-187-2400	C-11	3	5306-00-616-1224	C-13	1
5310-00-187-2400	C-12	3	5306-00-624-9713	C-9	2
5310-00-187-2400	C-13	3	5310-00-637-9541	C-8	2
5310-00-167-0834	C-5	2	5310-00-637-9541	C-11	2
9540-00-197-9846	BULK		5310-00-637-9541	C-12	2
9540-00-197-9850	BULK		5310-00-637-9541	C-13	2
4730-00-203-3168	C-4	5	4730-00-724-1998	C-5	4
9530-00-228-9315	BULK		5305-00-728-6350	C-14	1
9530-00-228-9316	BULK		5305-00-840-5895	C-10	4
9535-00-231-8230	BULK		5975-00-878-3791	C-6	1
4730-00-288-6997	C-4	3	4730-00-932-7511	C-4	1
1670-00-360-0551	C-9	1	5310-00-934-9751	C-5	1

PART NUMBER INDEX

FSCM	PART NUMBER	FIGURE NO.	ITEM NO.	FSCM	PART NUMBER	FIGURE NO.	ITEM NO.
58536	A-A-232	C-5	5	98313	FDA 1658-3	C-9	2
28977	AA52525-24	C-5	3	32938	FIG 1620-1	C-5	6
99237	QQA200-8	BULK		81349	MIL-R-11461	C-6	1
88044	AN4-5A	C-3	1	81348	MIL-S-6758	BULK	
88044	AN4-11A	C-10	1	01349	MIL-T-7181	C-9	1
88044	AN5-5A	C-2	1		TYPE A1A		
88044	AN5-6A	C-7	1	96906	MS27039-0813	C-10	4
88044	AN6-6A	C-8	1	96906	MS35338-46	C-8	2
88044	AN6-6A	C-12	1	96906	MS35338-46	C-11	2
88044	AN6-6A	C-13	1	96906	MS35338-46	C-12	2
88044	AN6-7A	C-11	1	96906	MS35338-46	C-13	2
88044	AN742-12CB	C-4	7	96906	MS51966-90	C-14	1
88044	AN9102C	C-4	4	45225	P74-144	C-6	2
88044	AN935-416	C-3	2	81348	QQA200-8	BULK	
88044	AN935-416	C-10	2	81348	QQA250-8	BULK	
88044	AN935-516	C-2	2	81348	QQA250-11	BULK	
88044	AN935-516	C-7	2	14127	SHD 11	C-4	6
88044	AN960-PD-416	C-3	3	97393	SL601-4-8C	C-1	1
88044	AN960-PD-416	C-10	3	97393	SL601-5-10C	C-1	2
88044	AN960-PD-515	C-2	3	97393	SL601-6-8C	C-1	3
88044	AN960-PD-515	C-7	3	97393	SL601-6-12C	C-1	4
88044	AN960-PD-616	C-8	3	59875	TX90790-34	C-5	2
88044	AN960-PD-616	C-11	3	81348	WV-P-460	C-5	4
88044	AN960-PD-616	C-12	3	81348	WV-P-521	C-4	5
88044	AN960-PD-616	C-13	3	05415	134MKC1	BULK	
81348	ASTM A366	BULK		00624	4738-4-6	C-4	1
19422	BM12297-06	C-5	1	03958	896WM	C-4	3
79470	C3409X4	C-4	2				

**APPENDIX D
EXPENDABLE/DURABLE SUPPLIES AND MATERIELS LIST**

D-1. Scope.

This listing is for informational purposes only and is not the authority to requisition the listed items. These items are authorized to you by CTA 50-970, Expendable/Durable Items (Except Medical, Class V, Repair Parts, and Heraldic Items), or CTA 8-100, Army Medical Department Expendable/Durable Items.

D-2. Explanation of Columns.

a. Column 1, Item Number. Column 1 is the number is assigned to the entry in the listing and is referenced in the narrative instructions to identify the materiel (e.g., "Use cleaning solvent, Item 1, App D").

b. Column 2, Level. Column 2 identifies the lowest level of maintenance that requires the listed item.

c. Column 3, National Stock Number. Column 3 is the National Stock Number assigned to the item; use it to request or requisition the item.

d. Column 4, Description. Column 4 indicates the Federal item name, and if required, a description to identify the item. The last line for each item indicates the Federal Supply Code for Manufacturer (FSCM) in parentheses followed by the part number.

e. Column 5, Unit of Measure (U/M). Column 5 indicates the measure used in performing the actual maintenance function. This measure is expressed by a two-character alphabetical abbreviation (e.g., ea, in, pr). If the unit of measure differs from the unit of issue, requisition the lowest unit of issue that will satisfy your requirements.

(1)	(2)	(3)	(4)	(5)
ITEM NUMBER	LEVEL	NATIONAL STOCK NUMBER	DESCRIPTION	U/M
1	AVIM	8040-00-877-9872	ADHESIVE, SEALANT (81349)..... MIL-A-46106	TU
2	AVIM	8015-00-271-1511	BAG, COTTON, MAILING (81348)..... PPP-B-20	BD
3	AVIM	8010-00-852-9034	ENAMEL, GRAY (81348) 16187	PT
4	AVIM	8010-00-159-4520	ENAMEL, WHITE (81348) 17773.....	PT
5	AVIM	8010-00-297-0593	PRIMER, COATING (81348) TT-P-1757.....	PT
6	AVIM	3439-00-063-5200	ROD, WELDING (81348) 5356.....	LB

APPENDIX E
ILLUSTRATED LIST OF MANUFACTURED ITEMS

E-1. Scope.

This Appendix includes simplified line drawing illustrations for all specially manufactured connectors, braces, brackets and stands used in the Electric/Instrument Shop. The special tie down brackets are designed to prevent damage to equipment or to the shelter during transport.

E-2. General.

- a. Supporting text, consisting of instructional data and a list of bulk materiel is included on each illustration.
- b. Dimensions are given in U.S. Standard measures.
- c. Part numbers have been assigned to each special connector, brace, bracket and stand for ease of recognition and a basis of uniformity between other AVIM manuals.

E-3. Reference Index.

PART NUMBER	NOMENCLATURE	FIG NO.
20083250	Water Feed thru Connector	1
20083251	Book Rack	2
20083253	ECU Support Frame	3
20083254	ECU Security Bar, Upper	4
20083255	ECU Security Bar, Lower	5
20083256	Storage Chest Bracket, RH	6
20083257	Storage Chest Bracket, LH	7
20083258	Cabinet Bracket	8
20083267-1	Tool Box Rack (6 Unit)	9
20083274	Exhaust Gas Tester Bracket	10

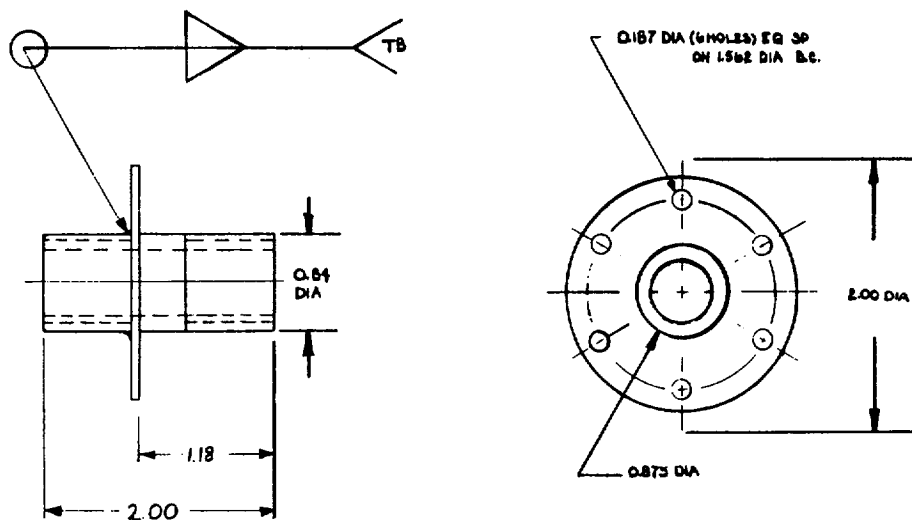

NOTES:
 1. FABRICATE FROM:
 A. SHEET STEEL, 18 GAUGE
 NSN 9515-00-141-8066.
 B. NIPPLE, PIPE, 1/2" X 2"
 NSN 4730-00-196-1493.
 2. ALL DIMENSIONS ARE IN INCHES.

Figure 1. Water Feed thru Connector Part No. 20083250

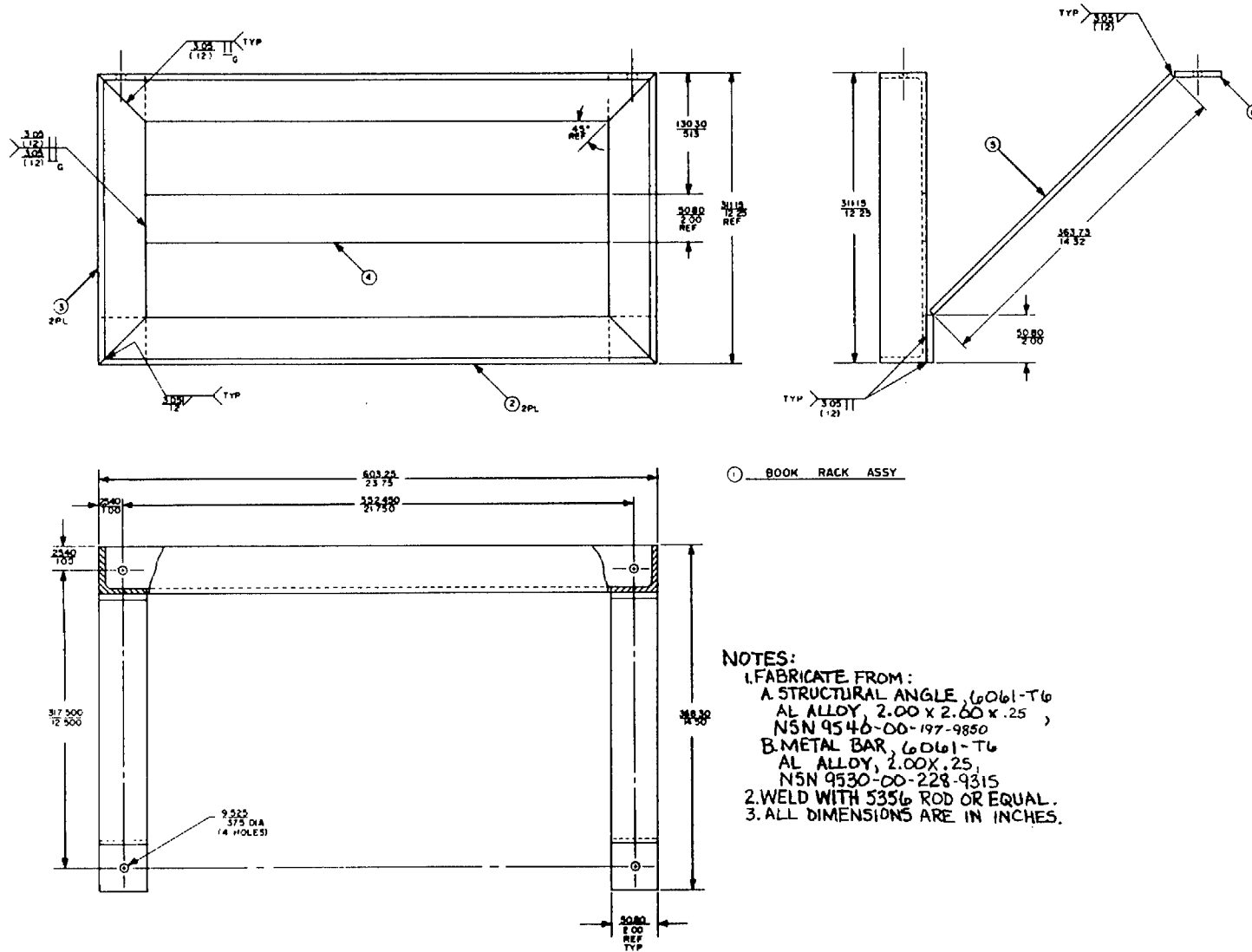

Figure 2. Book Rack Part No. 20083251

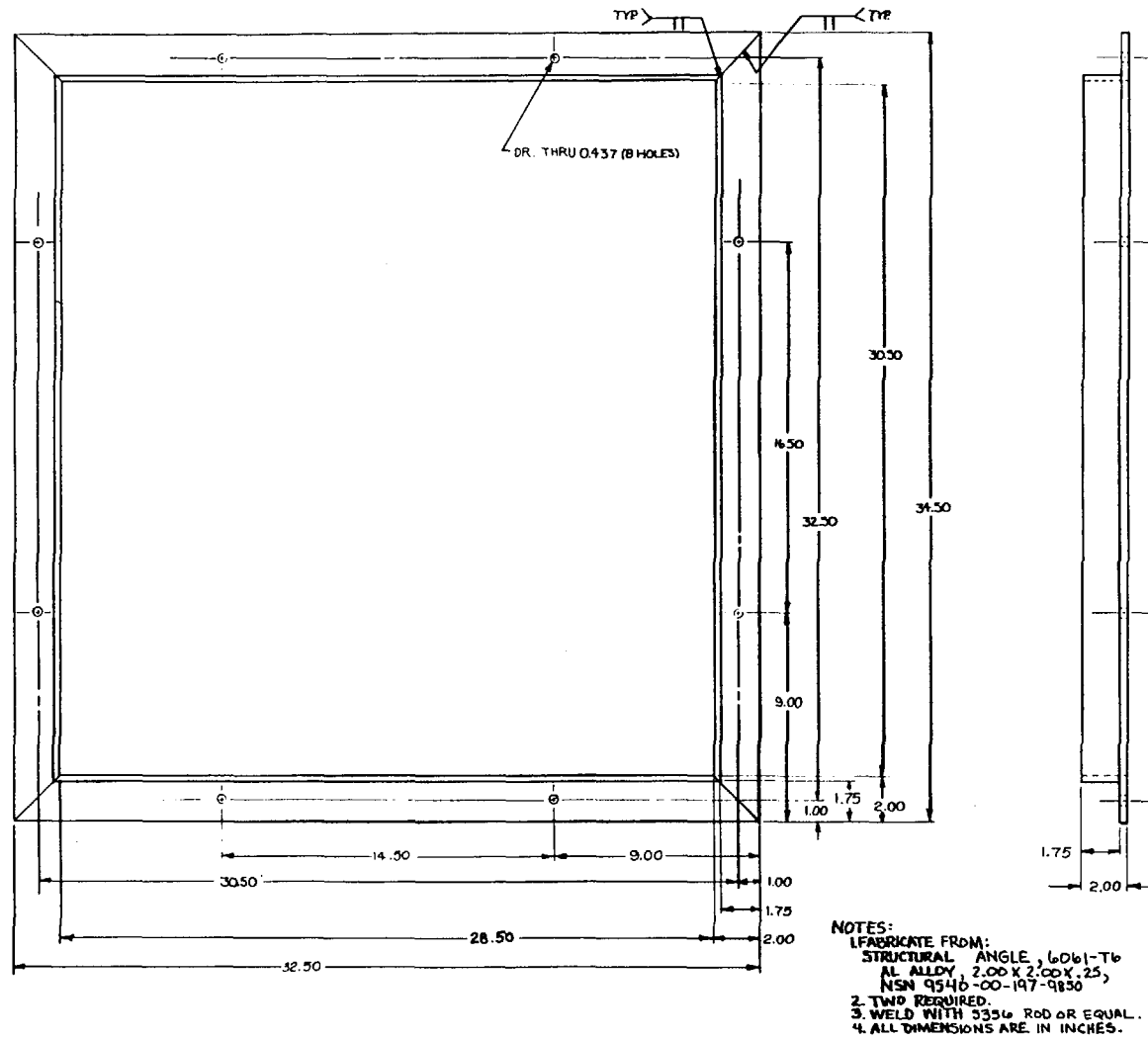
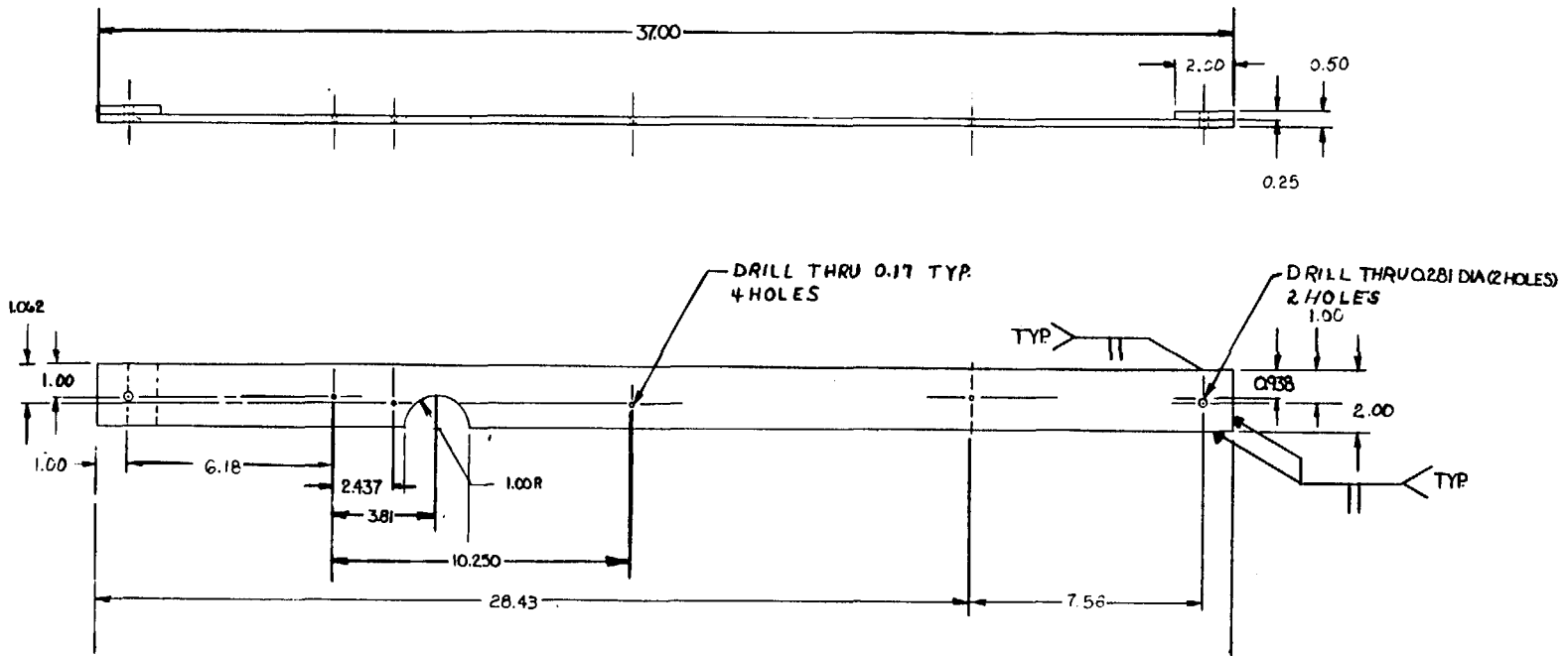
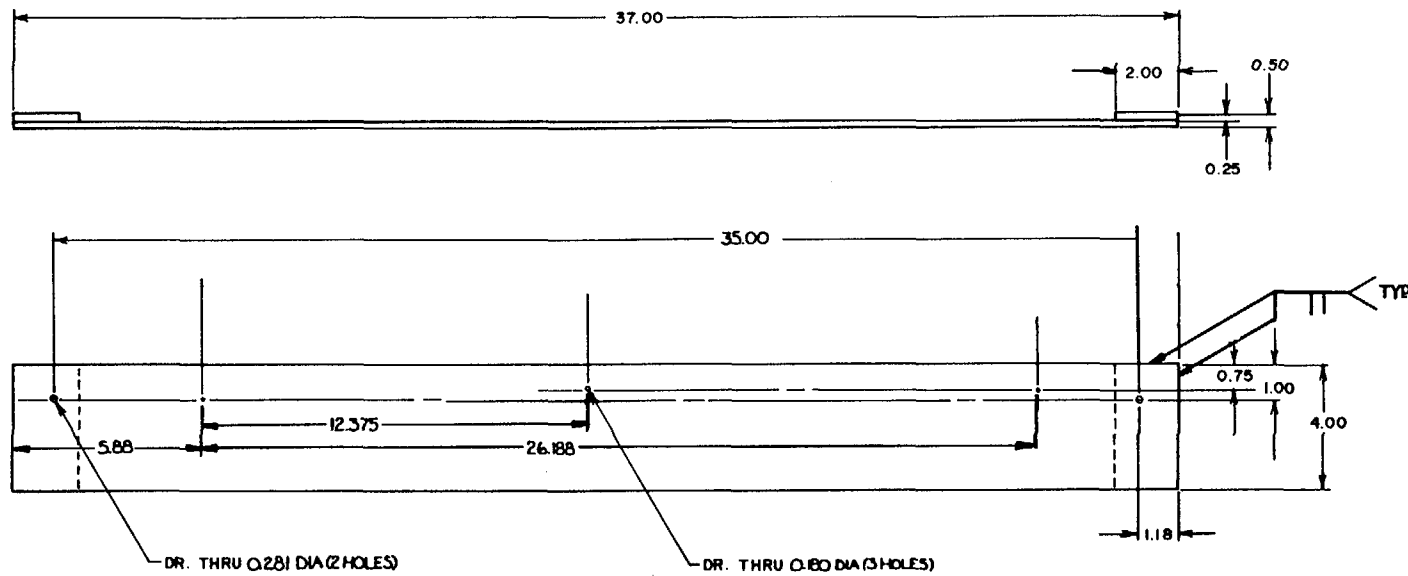

Figure 3. ECU Support Frame Part No. 20083253



- NOTES:
1. FABRICATE FROM:
METAL BAR, 6061-T6
AL ALLOY, 2.00 X .25,
NSN 9530-00-228-9315
 2. TWO REQUIRED.
 3. WELD WITH 5356 ROD OR EQUAL.
 4. ALL DIMENSIONS ARE IN INCHES.

Figure 4. ECU Security Bar, Upper Part No. 20083254



- NOTES:
1. FABRICATE FROM:
METAL BAR, 6061-T6
AL ALLOY, 4.00 X .25,
NSN 9530-00-228-9316
 2. TWO REQUIRED
 3. WELD WITH 5356 ROD OR EQUAL.
 4. ALL DIMENSIONS ARE IN INCHES.

Figure 5. ECU Security Bar, Lower Part No. 20083255

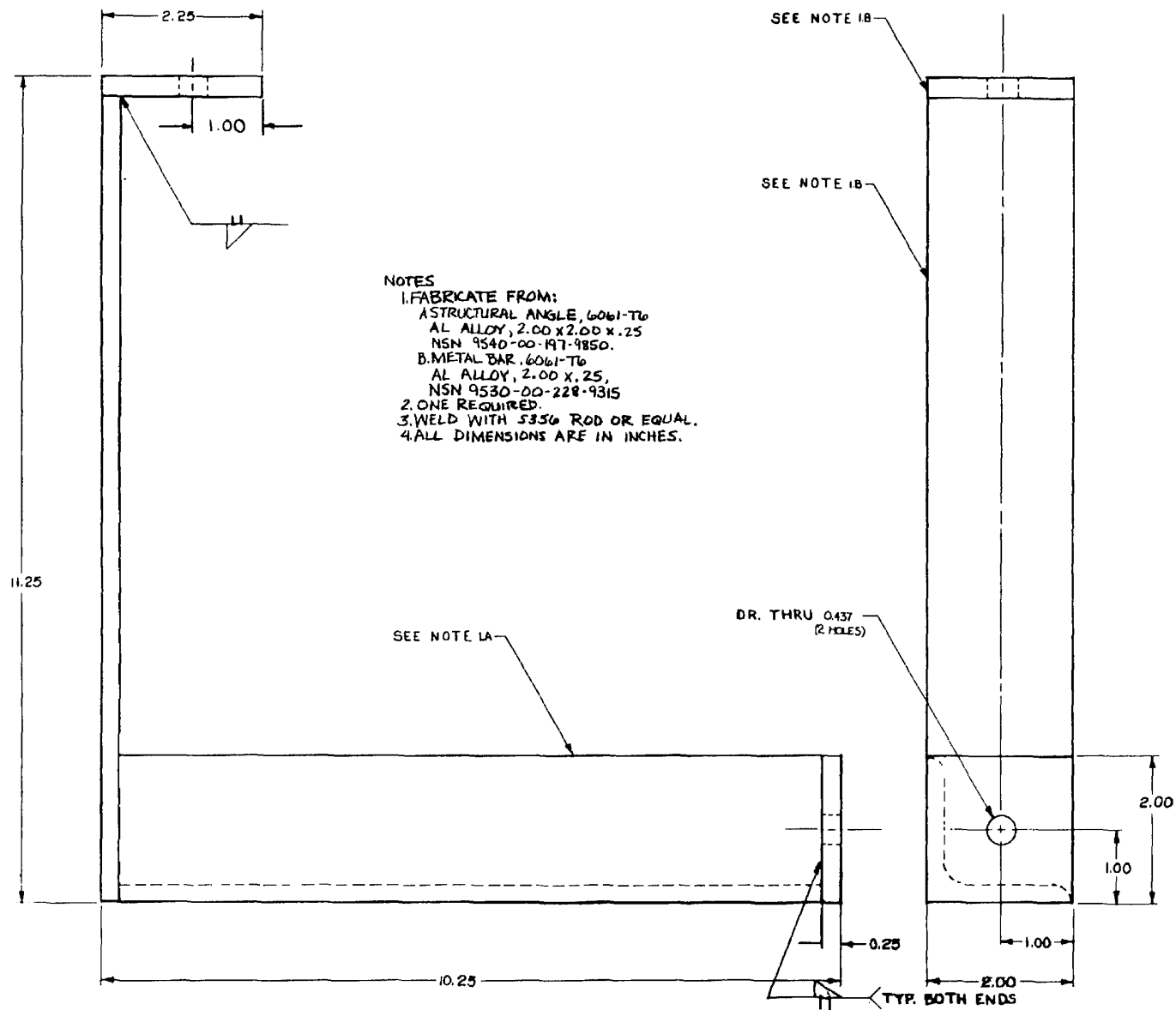

Figure 6. Storage Chest Bracket, RH Part No. 20083256

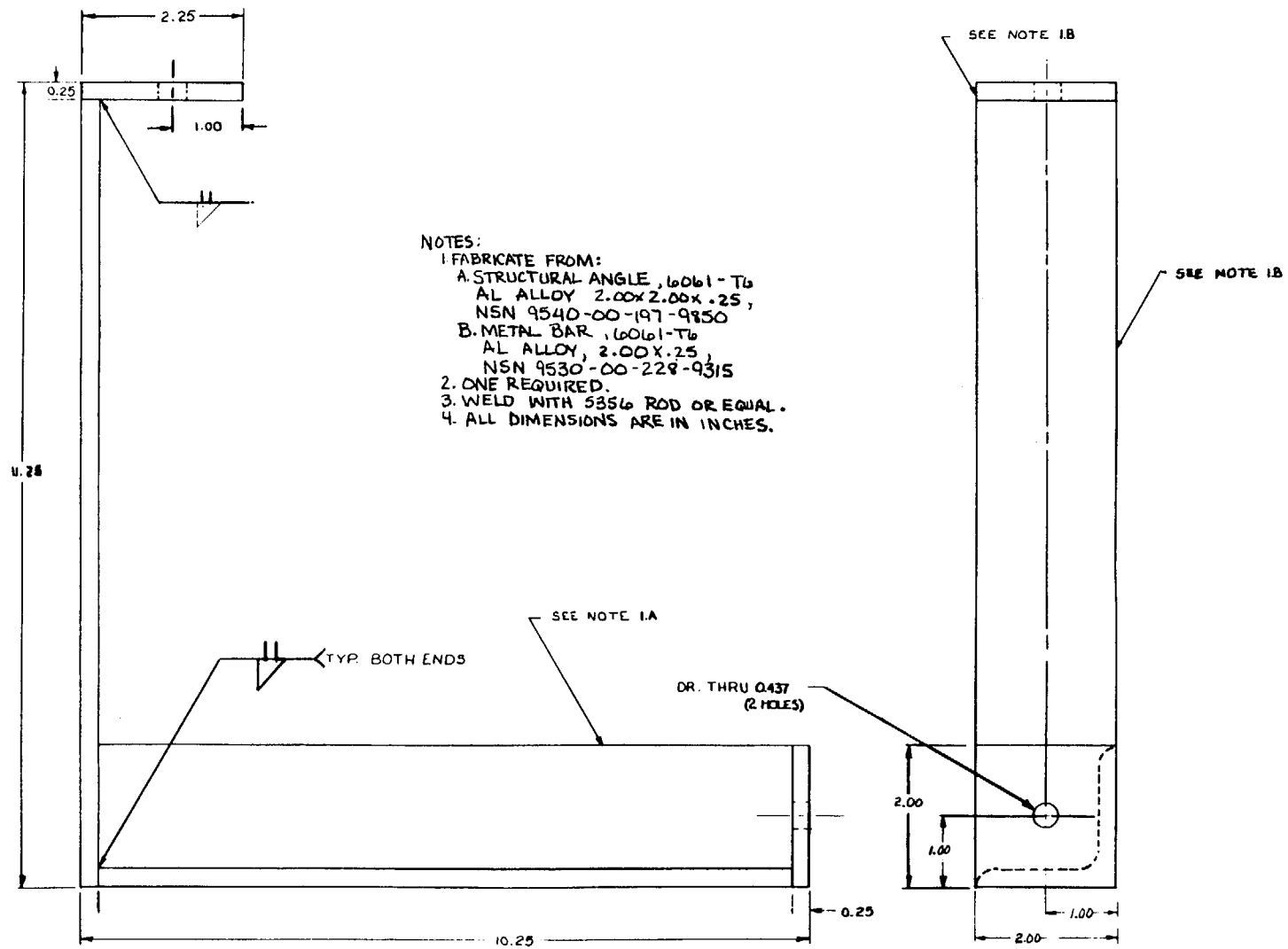
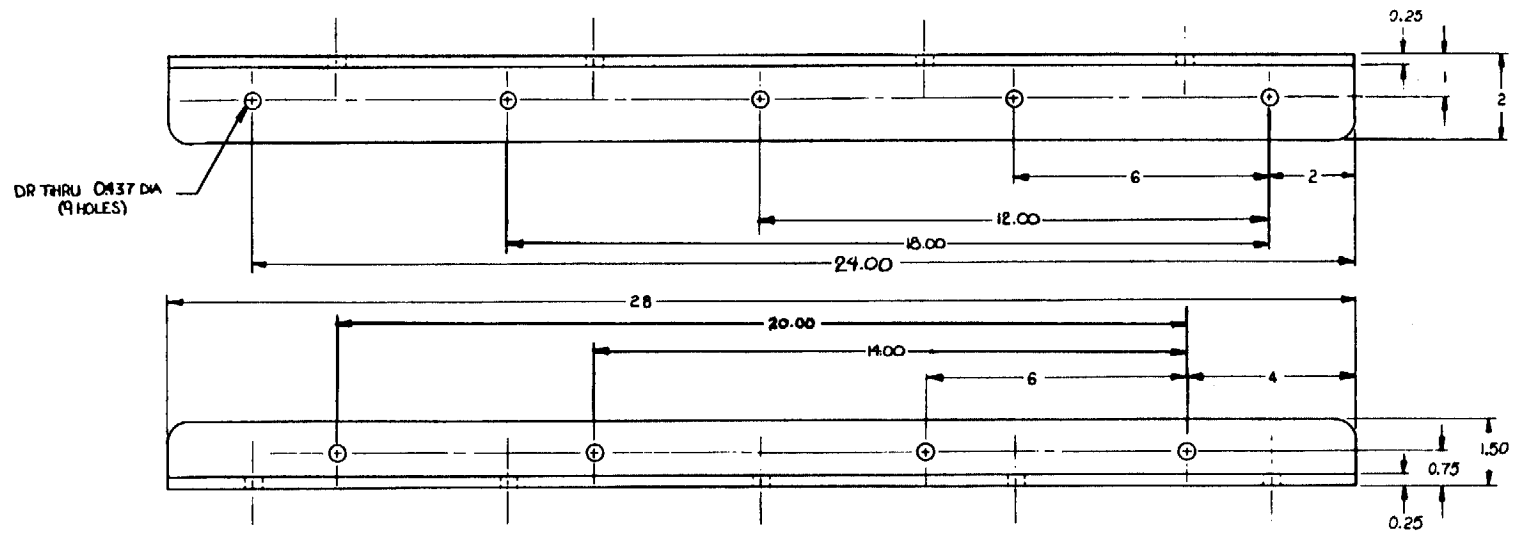

Figure 7. Storage Chest Bracket, LH Part No. 20083257



- NOTES:
1. FABRICATE FROM:
STRUCTURAL ANGLE, 6061-T6
AL ALLOY, 2.00 X 1.50 X .25,
NSN 9540-00-197-9846.
 2. TWO REQUIRED
 3. WELD WITH 5356 ROD OR EQUAL.
 4. ALL DIMENSIONS ARE IN INCHES.

Figure 8. Cabinet Bracket Part No. 20083258

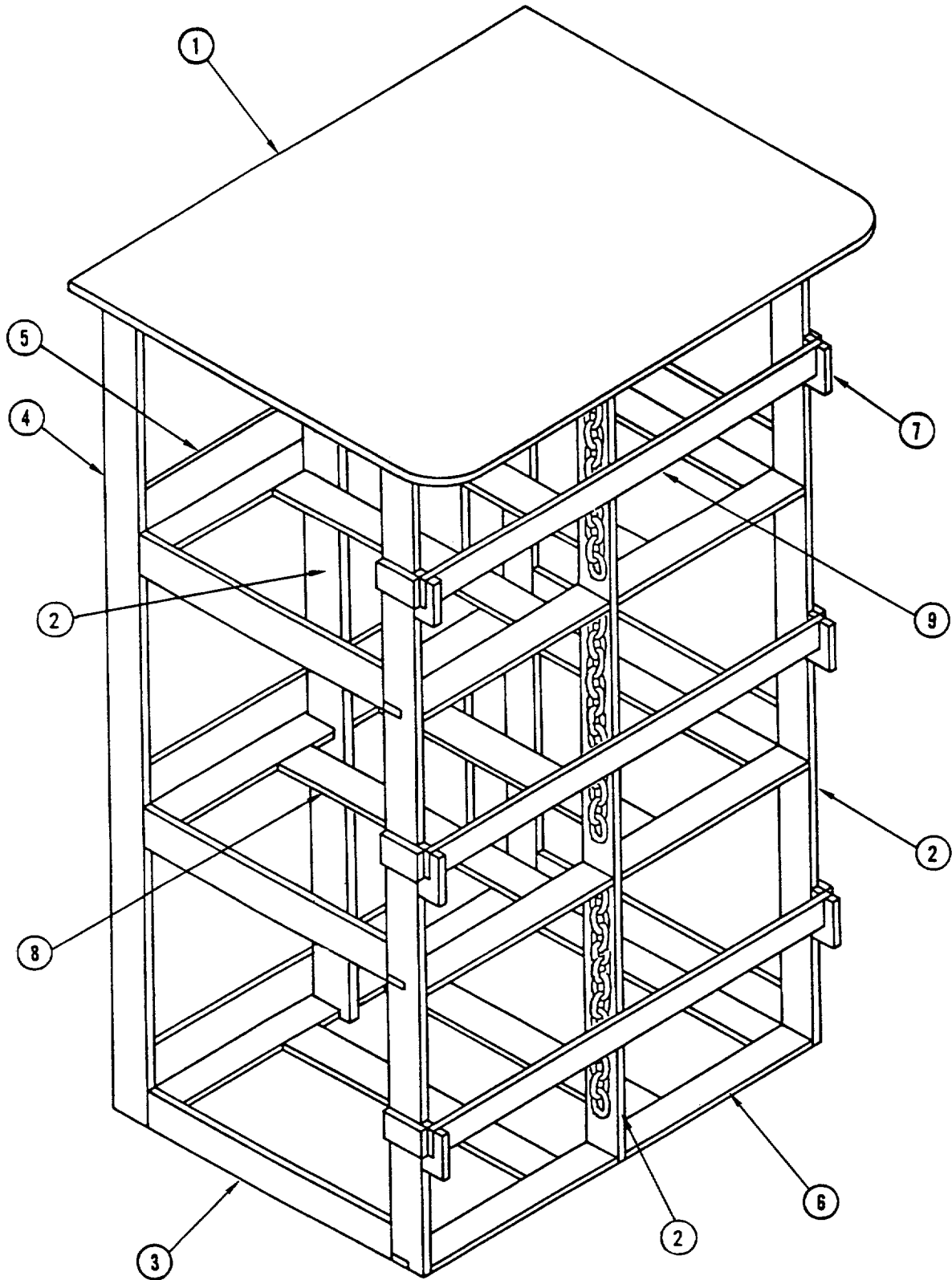
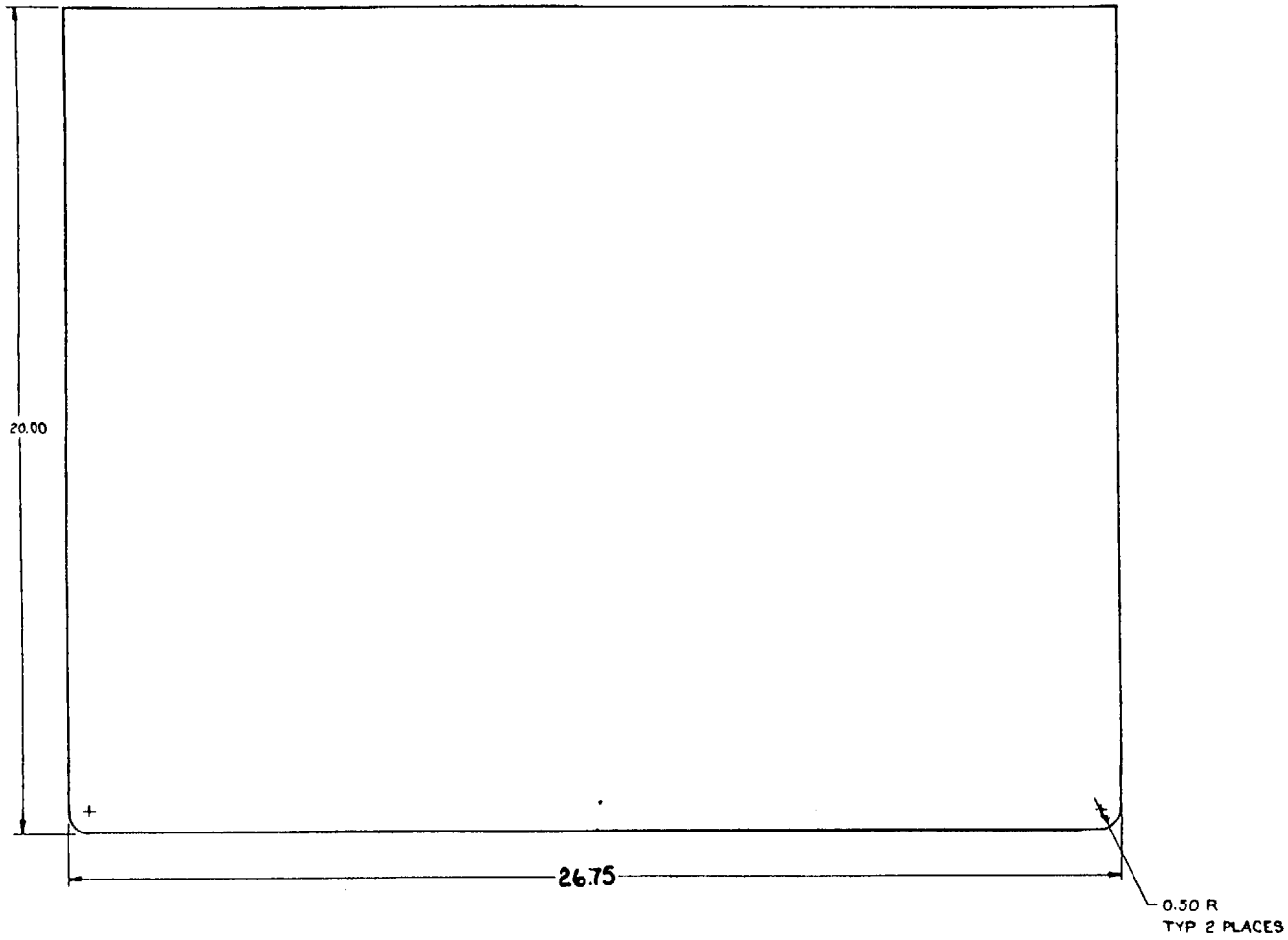
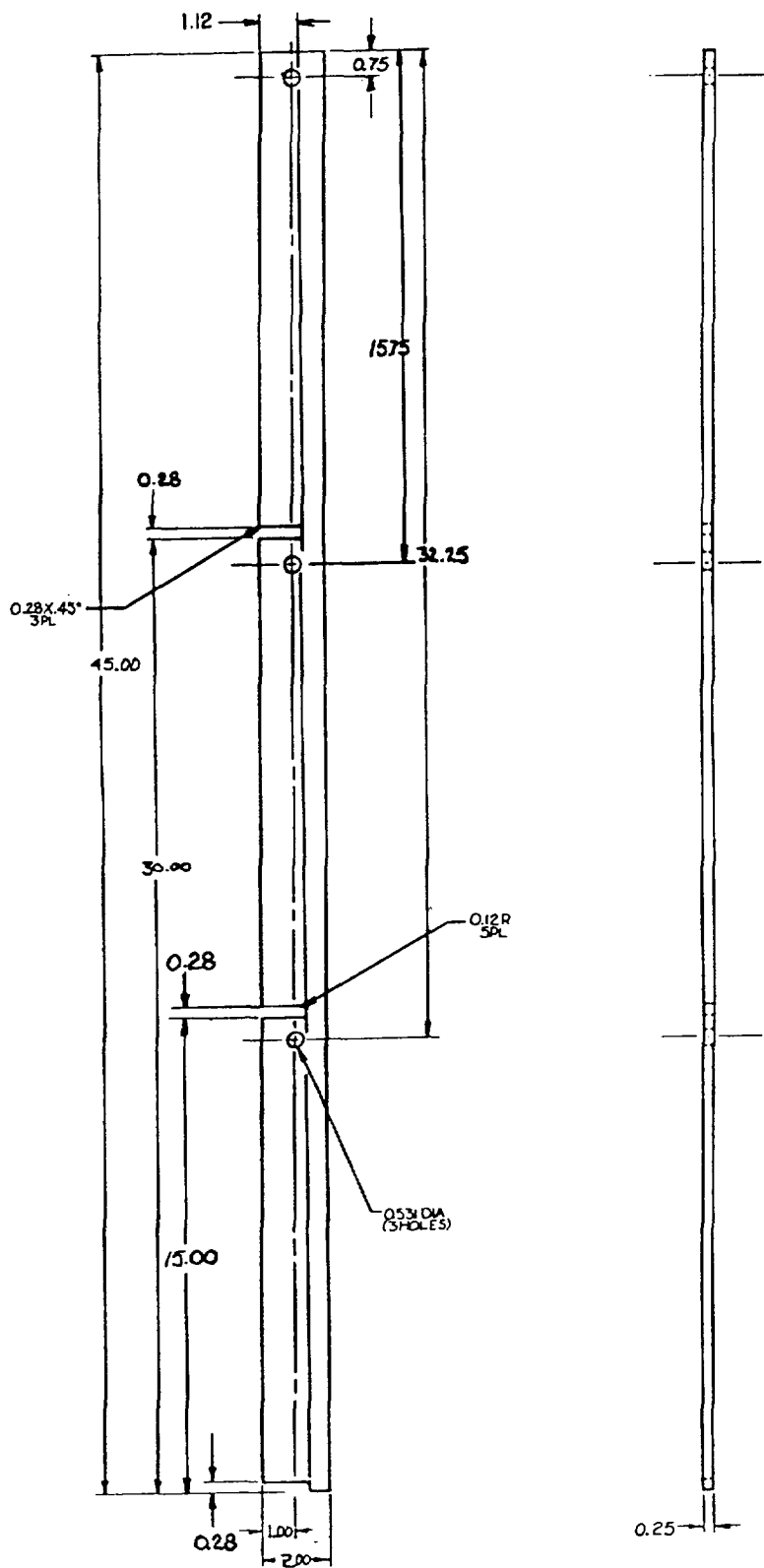

Figure 9. Tool Box Rack (6 Unit) Part No. 20083267-1 (Sheet 1 of 10)



- NOTES:
1. FABRICATE FROM:
METAL PLATE, 6061-T6
AL ALLOY,
NSN 9535-00-231-8230
2. WELD WITH 5356 ROD OR EQUAL
3. ALL DIMENSIONS ARE IN INCHES.

Figure 9. Tool Box Rack (6 Unit) Part No. 20083267-1 (Sheet 2 of 10)



- NOTES:
1. FABRICATE FROM:
METAL BAR 6061-T6
AL ALLOY, 2.00 X .25
NSN 9530-00-228-9315
 2. FOUR REQUIRED; TWO
WITH HOLES AS SHOWN,
TWO W/O HOLES.
 3. WELD WITH 5356 ROD OR EQUAL.
 4. ALL DIMENSIONS ARE IN INCHES.

Figure 9. Tool Box Rack (6 Unit) Part No. 20083267-1 (Sheet 3 of 10)

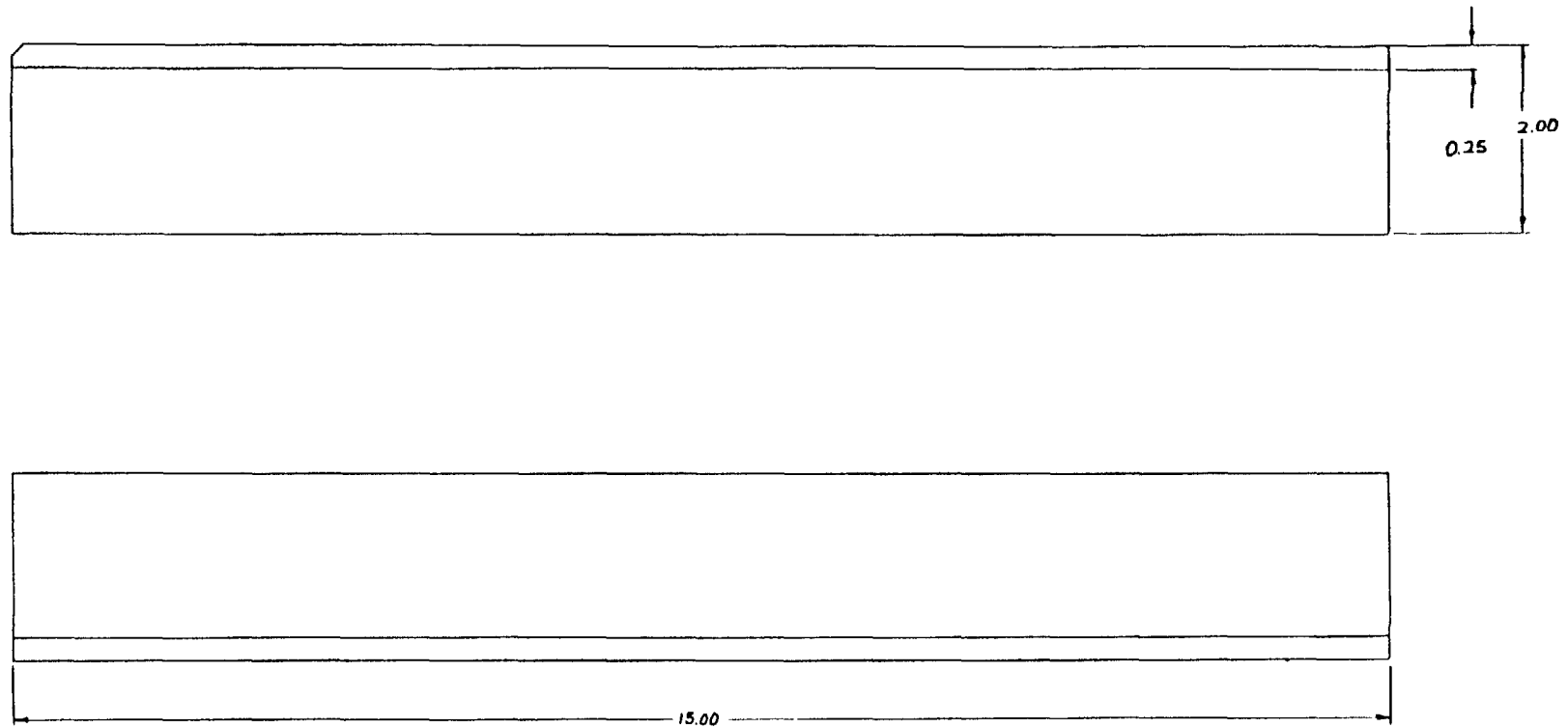

- NOTES:
1. FABRICATE FROM:
STRUCTURAL ANGLE 6061-T6
AL ALLOY 2.00X 2.00X .25
NSN 9540-00-197-9850
2. SIX REQUIRED.
3. WELD WITH 3356 ROD OR EQUAL.
4. ALL DIMENSIONS ARE IN INCHES.

Figure 9. Tool Box Rack (6 Unit) Part No. 200832670-1 (Sheet 4 of 10)

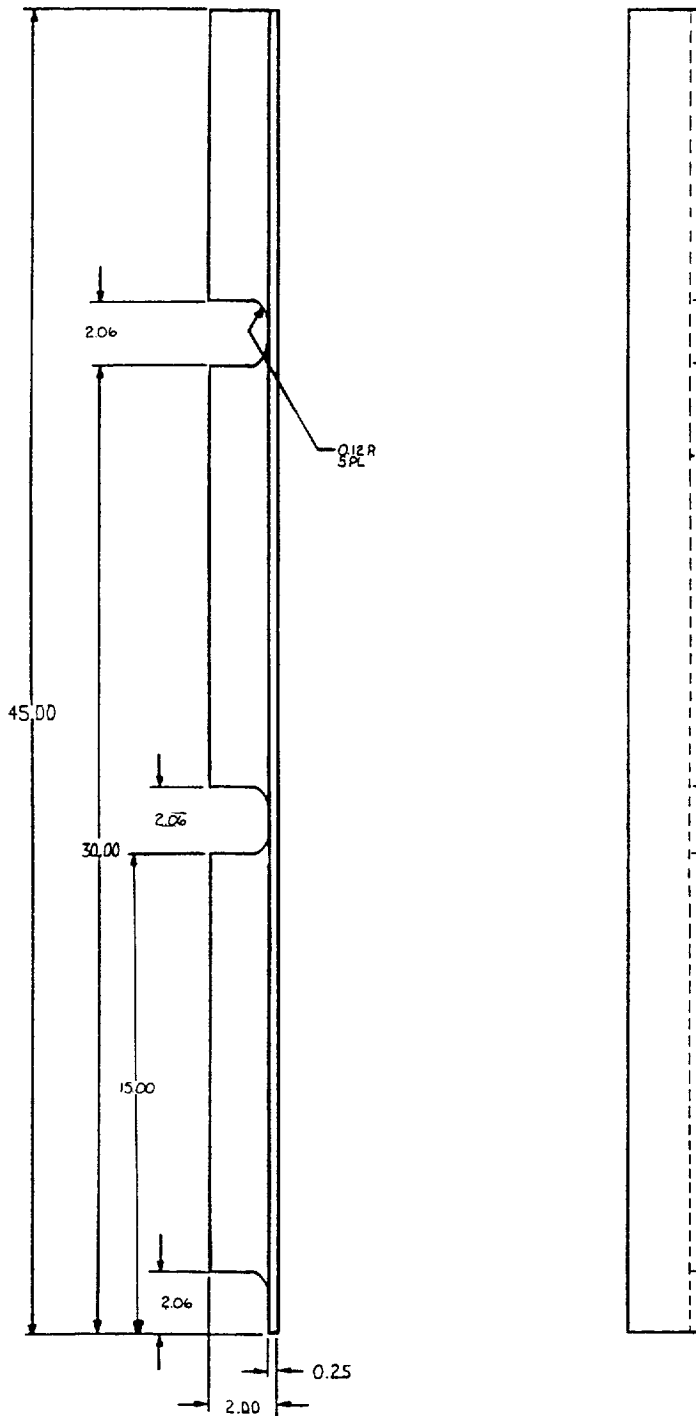

- NOTES:
1. FABRICATE FROM:
STRUCTURAL ANGLE, 6061-T6
AL ALLOY, 2.00 X 2.00 X .25
NSN 9540-00-197-9850
 2. TWO REQUIRED; ONE AS SHOWN
ONE OPPOSITE
 3. WELD WITH 5356 ROD OR EQUAL
 4. ALL DIMENSIONS ARE IN INCHES

Figure 9. Tool Box Rack (6 Unit) Part No. 20083267-1 (Sheet 5 of 10)

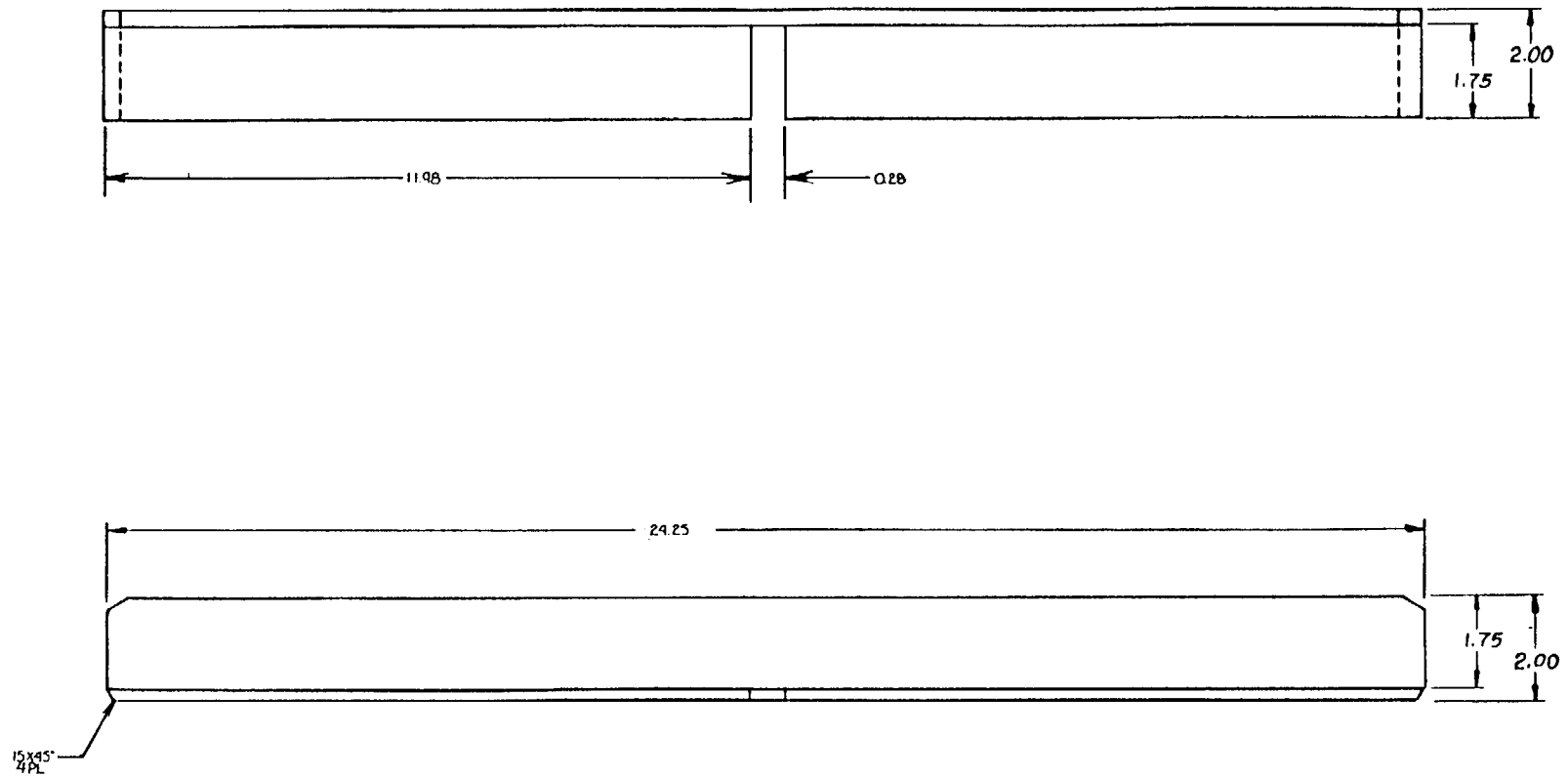

- NOTES:
1. FABRICATE FROM:
STRUCTURAL ANGLE, 6061-T6
AL ALLOY, 2.00 x 2.00 x .25,
NSN 9540-00-197-9850
 2. THREE REQUIRED.
 3. WELD WITH 5356 ROD OR EQUAL.
 4. ALL DIMENSIONS ARE IN INCHES.

Figure 9. Tool Box Rack (6 Unit) Part No. 20083267-1 (Sheet 6 of 10)

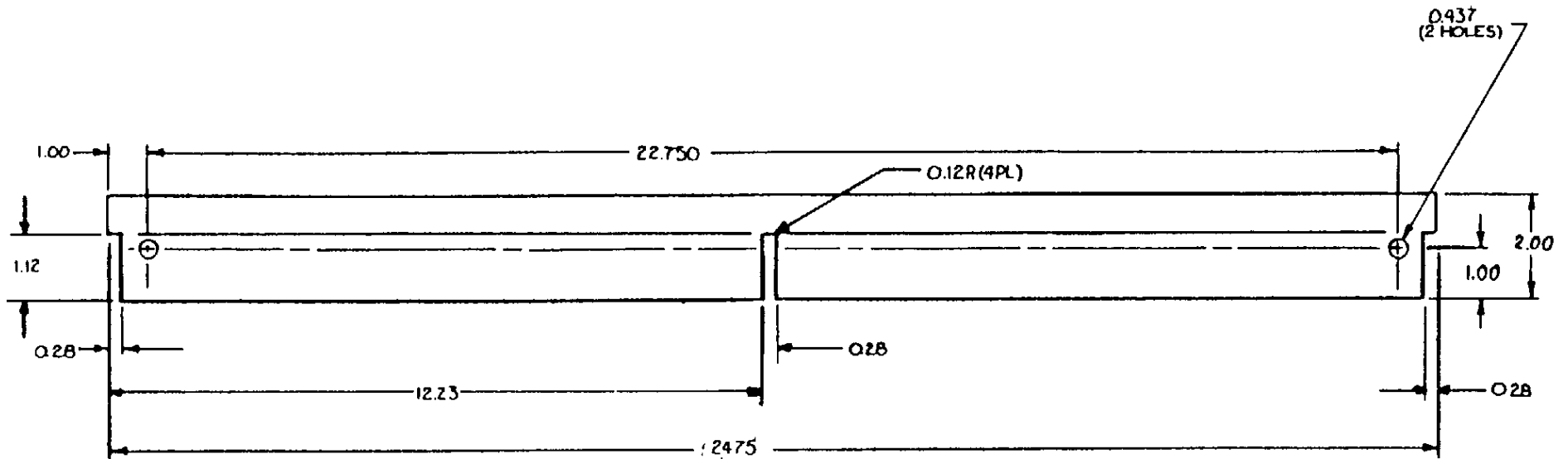

NOTES:

1. FABRICATE FROM:
METAL BAR, 6061-T6
AL ALLOY, 2.00 x .25,
NSN 9530-00-228-9315
2. THREE REQUIRED; ONE
WITH HOLES AS SHOWN,
TWO W/O HOLES.
3. WELD WITH S356 ROD OR EQUAL
4. ALL DIMENSIONS ARE IN INCHES.

Figure 9. Tool Box Rack (6 Unit) Part No. 20083267-1 (Sheet 7 of 10)

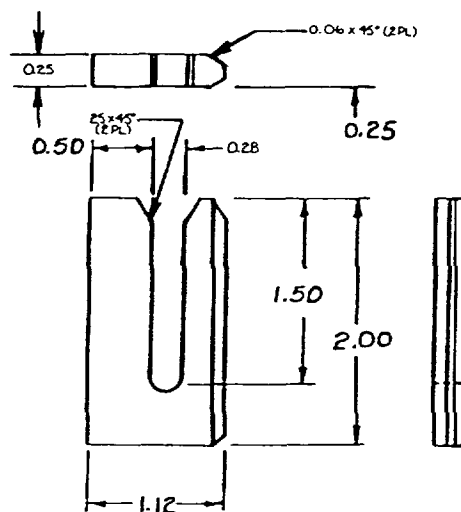

- NOTES:
1. FABRICATED FROM:
METAL BAR, 6061-T6
AL ALLOY, 2.00 X .25,
NSN 9530-00-228-9315
 2. 51X REQUIRED
 3. WELD WITH 5356 ROD OR EQUAL
 4. ALL DIMENSIONS ARE IN INCHES.

Figure 9. Tool Box Rack (6 Unit) Part No. 20083267-1 (Sheet 8 of 10)

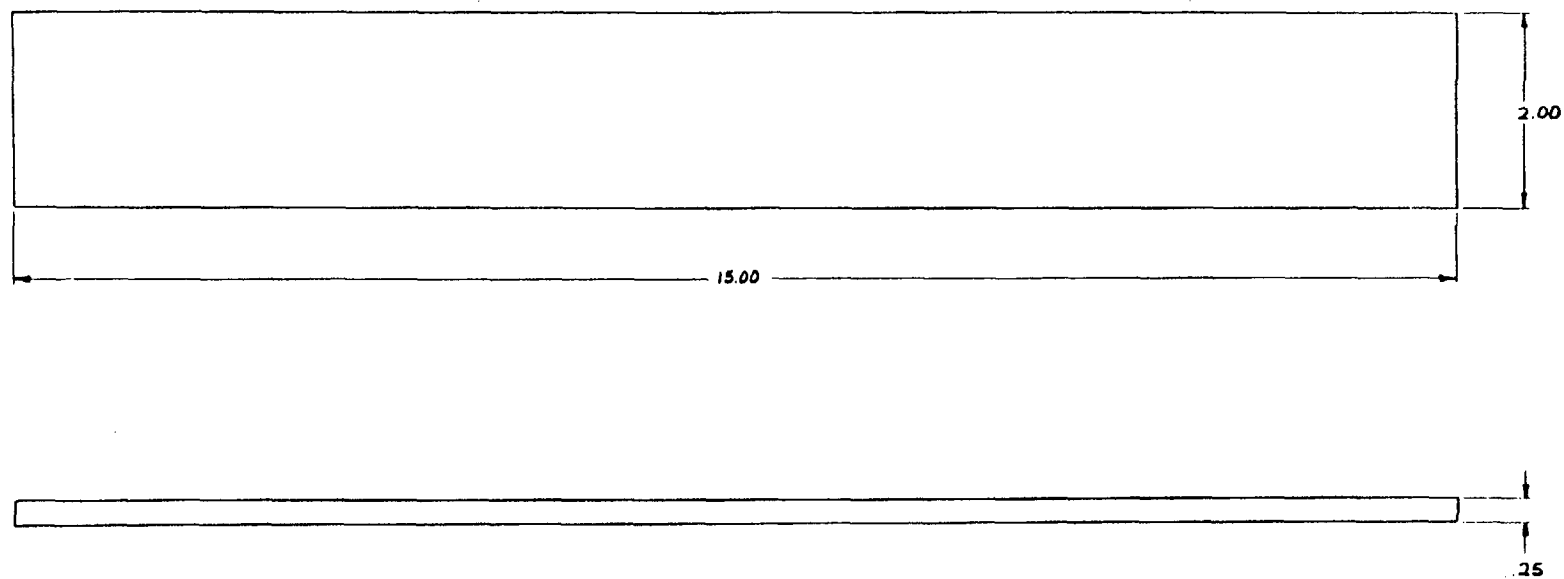

- NOTES:
- 1. FABRICATED FROM:
METAL BAR, 6061-T6
AL ALLOY, 2.00x.25,
NSN 9530-00-228-9315
 - 2. SIX REQUIRED;
 - 3. WELD WITH 5356 ROD OR EQUAL.
 - 4. ALL DIMENSIONS ARE IN INCHES.

Figure 9. Tool Box Rack (6 Unit) Part No. 20083267-1 (Sheet 9 of 10)

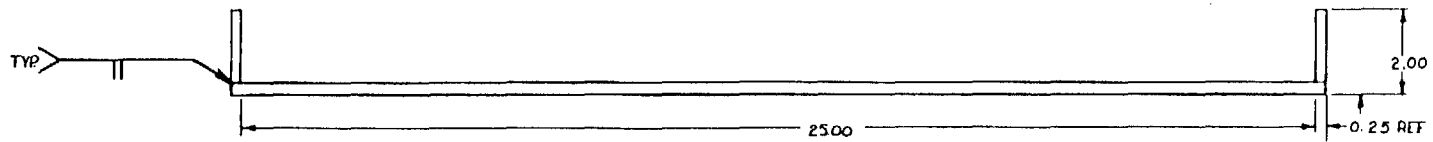

- NOTES:
1. FABRICATE FROM:
METAL BAR 6061-T6,
AL ALLOY, 2.00x.25
NSN 9530-00-229-9315
 2. THREE REQUIRED
 3. WELD WITH 5356 OR EQUAL.
 4. ALL DIMENSIONS ARE IN INCHES.

Figure 9. Tool Box Rack (6 Unit) Part No. 20083267-1 (Sheet 10 of 10)

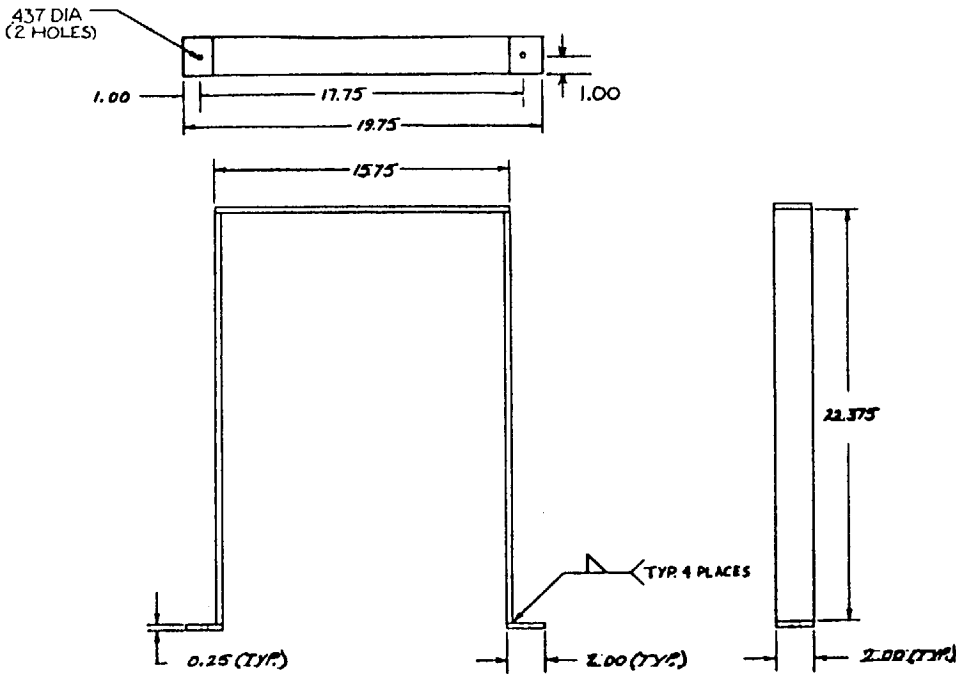

- NOTES:
1. FABRICATE FROM:
METAL BAR, 6061-T6
AL. ALLOY, 2.00 X .25,
NSN 9530-00-228-9315
2. WELD WITH 5356 ROD OR EQUAL
3. ALL DIMENSIONS ARE IN INCHES.

Figure 10. Exhaust Gas Tester Bracket Part No. 20083274

**APPENDIX F
TORQUE LIMITS**

Bolt Size	Tension Loading
1/4-28	50-70 inch pounds
5/16-24	100-140 inch pounds
3/8-24	160-190 inch pounds

The above torque loads may be used on all cadmium-plated fine thread steel bolts which have approximately equal number of threads and equal face bearing areas. Size refers to bolt shank diameter or inside diameter of nut and thread indicates number of threads per inch.

ALPHABETICAL INDEX

Subject	Paragraph No.	Subject	Paragraph No.
A			
Allocation Chart, Maintenance (MAC)		Compressed Air	
Column Explanation		Connection	2-6.a
MAC, Section II.....	B-3	Disconnecting.....	2-8.b
Remarks, Section IV	B-5	Counterbalance Cable Removal.....	2-1.d
Tools and Test Equipment		D	
Requirements, Section III	B-4	Destruction of Army Materiel to	
Functions, Maintenance	B-2	Prevent Enemy Use.....	1-4
B			
Bin Storage Cabinet		E	
Positioning for Operation.....	2-3.a	ECU Shelves	
Repositioning for Transport.....	2-11.e	Closing.....	2-11.d
Bolts and Washers		Lowering Procedures	2-2
For Equipment Tie Down.....	2-10	ECUs	
Safeguarding	2-4	Connecting Power.....	2-5.b
Book Rack		Disconnecting.....	2-9.c
Inspect.....	3-16	Positioning for Operation.....	2-3.c
Repair	3-17	Repositioning for Transport.....	2-11.a
Replace.....	3-18	Electric/Instrument Shop Characteristics	1-6
C			
Cabinet, Bin Storage		Electric/Instrument Shop, Setup of	
Positioning for Operation.....	2-3.a	Upon Initial Receipt.....	2-1
Repositioning for Transport.....	2-11.e	Counterbalance Cable Removal.....	2-1.d
Cable Removal, Counterbalance.....	2-1.d	Leveling, Initial.....	2-1.b
Cable, Main Power		Safety Instructions, Supplemental	2-1.c
Connecting	2-5	Electric Power.....	2-5
Disconnecting.....	2-9.d	Connecting to ECU	2-5.b
Characteristics	1-6	Main Power Cable Connection.....	2-5.a
Chart, Maintenance Allocation (MAC)		Power On to Shop.....	2-5.c
Column Explanation		Equipment Improvement Recommendations	
MAC, Section II.....	B-3	(EIRs), Reporting	1-3
Remarks, Section IV	B-5	Equipment, Checking	3-5
Tools and Test Equipment		Equipment, Shop Positioning for Operation.....	2-3
Requirements, Section III	B-4	Bin Storage Cabinet.....	2-3.a
Functions, Maintenance	B-2	ECUs	2-3.c
Checking Equipment	3-5	Exhaust Gas Tester	2-3.b
Circuit Breaker Panel	2-9.b	Security Bars, ECU, Attaching	2-3.e
Components, Location and Description		Support Frames, Storing ECU.....	2-3.d
of Major Ones	1-7	Equipment, Shop, Repositioning for Transport	2-11
		Bin Storage Cabinet	2-11.f
		Closing ECU Shelves	2-11.d
		ECUs	2-11.b

ALPHABETICAL INDEX (Cont)

Subject	Paragraph No.	Subject	Paragraph No.
Exhaust Gas Tester	2-11.e	Floor Insert Fasteners Plugs - Inspect	3-19
Repositioning ECUs in Support		Ground Rod/Strap - Inspect.....	3-15
Frames	2-11.c	Insert Fasteners and Bolts - Inspect	3-6
Support Frames, ECU Installation.....	2-11.a	Insert Fasteners - Replace.....	3-7
Exhaust Gas Tester		Water Feed Thru Connector - Inspect	3-13
Positioning for Operation.....	2-3.b	Water Feed Thru Connector - Replace.....	3-14
Repositioning for Transport.....	2-11.e	Water/Oil Separator Air Hose and	
Expendable/Durable Supplies and		Fittings - Inspect	3-11
Materials List		Water/Oil Separator Air Hose -	
Column Explanation	D-2	Replace.....	3-12
External Ground Rod		Water/Oil Separator Mounting -	
Installation.....	2-5.d	Inspect.....	3-10
Removal.....	2-9.e		
		L	
F		Leveling	
Fire Extinguisher Mounting - Inspect	3-9	Checking.....	2-7
Fire Extinguisher - Removal/Installation.....	3-8	Initial Shop Setup.....	2-1.b
Fixed Equipment/Components -		Location and Description of Major	
Removal/Installation.....	3-20	Components.....	1-7
Floor Insert Fasteners and Plugs - Inspect.....	3-19	Lowering Procedures, ECU Shelves.....	2-2
Forms, Maintenance	1-2		
		M	
G		Maintenance Allocation Chart (MAC)	
Ground Rod/Strap - Inspect.....	3-15	Column Explanation	
		MAC, Section II.....	B-3
I		Remarks, Section IV	B-5
Insert Fasteners and Bolts - Inspect	3-6	Tools and Test Equipment	
Insert Fasteners - Replace.....	3-7	Requirements, Section III	B-4
Instructions, Maintenance		Functions, Maintenance	B-2
Book Rack - Inspect.....	3-16	Maintenance Instructions	
Book Rack - Repair.....	3-17	Book Rack - Inspect.....	3-16
Book Rack - Replace.....	3-18	Book Rack - Repair.....	3-17
Brackets, Special - Inspect	3-16	Book Rack - Replace.....	3-18
Brackets, Special - Repair	3-17	Fire Extinguisher Mounting - Inspect	3-9
Brackets, Special - Replace.....	3-18	Fire Extinguisher - Removal/	
Fire Extinguisher Mounting - Inspect	3-9	Installation.....	3-8
Fire Extinguisher - Removal/		Fixed Equipment/Components -	
Installation.....	3-8	Removal/Installation.....	3-20
Fixed Equipment/Components -		Floor Insert Fasteners Plugs - Inspect	3-19
Removal/Installation.....	3-20	Ground Rod/Strap - Inspect.....	3-15
		Insert Fasteners and Bolts - Inspect	3-6

ALPHABETICAL INDEX (Cont)

Subject	Paragraph No.	Subject	Paragraph No.
Insert Fasteners - Replace.....	3-7		
Water Feed Thru Connector - Inspect	3-13		
Water Feed Thru Connector - Replace.....	3-14		
Water/Oil Separator Air Hose and Fittings - Inspect	3-11		
Water/Oil Separator Air Hose - Replace.....	3-12		
Water/Oil Separator Mounting - Inspect.....	3-10		
Manufactured Items, Illustrated List Reference Index	E-3		
	N		
National Stock Number Index	Appendix C		
	P		
Part Number Index	Appendix C		
Power On to Shop.....	2-5.c		
Power, Electric	2-5		
Connecting to ECU	2-5.b		
Main Power Cable Connection.....	2-5.a		
Power On to Shop.....	2-5.c		
Power Shutdown.....	2-9		
Circuit Breaker Panel	2-9.b		
ECU.....	2-9.c		
Main Power Cable.....	2-9.d		
Preparation for Storage and Shipment.....	1-5		
	R		
Records, Maintenance.....	1-2		
References			
Dictionaries	A-1		
Logistics and Storage.....	A-3		
Maintenance.....	A-4		
Other Publications.....	A-5		
Publication Indexes.....	A-2		
Repair Parts	3-4		
Repair Parts and Special Tools List			
Column Explanation	C-3		
Locating Repair Parts.....	C-4		
National Stock Number and Part Number List.....	Appendix C		
Reports, Maintenance.....	1-2		
	S		
Safety Instructions, Supplemental	2-1.c		
Security Bars, ECU Attaching for Operation.....	2-3.e		
Setup of Instrument/Electric Shop Upon Initial Receipt	2-1		
Counterbalance Cable Removal.....	2-1.d		
Leveling, Initial.....	2-1.b		
Safety Instructions, Supplemental	2-1.c		
Shelves, ECU Closing.....	2-11.d		
Lowering Procedures	2-2		
Shipment/Storage, Preparation	1-5		
Shop Equipment, Positioning for Operation.....	2-3		
Bin Storage Cabinet	2-3.a		
ECUs	2-3.c		
Exhaust Gas Tester	2-3.b		
Security Bars, ECU, Attaching	2-3.e		
Support Frames, Storing ECU.....	2-3.d		
Shop Equipment, Repositioning for Transport	2-11		
Bin Storage Cabinet	2-11.f		
Closing ECU Shelves	2-11.d		
ECUs	2-11.b		
Exhaust Gas Tester	2-11.e		
Repositioning ECUs in Support Frames	2-11.c		
Support Frames, ECU Installation.....	2-11.a		
Special Brackets and Fabricated Components - Book Rack Mounting			
Inspect.....	3-16		
Repair	3-17		
Replace.....	3-18		
Storage Procedures	2-12		
Striking Shelter Shop Utilities (Other Than Electrical).....	2-8		
Disconnecting Compressed Air	2-8.b		
Disconnecting Water Supply	2-8.a		
Striking the Shelter.....	2-13		
Supplies and Materials List, Expendable			
Durable			
Column Explanation	D-2		
Scope	D-1		
Support Frames - Installation.....	2-11.a		
Storing	2-3.c		

ALPHABETICAL INDEX (Cont)

Subject	Paragraph No.	Subject	Paragraph No.
T		W	
Tools and Equipment, Common.....	3-1	Water Feed Thru Connector	
Tools and Equipment, Special.....	3-3	Inspect.....	3-13
Torque Limits.....	Appendix F	Replace.....	3-14
Torque Values	3-2	Water/Oil Separator	
U		Air Hose and Fittings - Inspect	3-11
Utilities, Other Shop.....	2-6	Air Hose - Replace.....	3-12
Compressed Air Connection	2-6.a	Mounting - Inspect	3-10
Water Supply Connection	2-6.b	Water Supply	
		Connection	2-6.b
		Disconnection.....	2-8.a

By Order of the Secretary of the Army:

Official:

JOHN A. WICKHAM, JR.
General, United States Army
Chief of Staff

DONALD J. DELANDRO
Brigadier General, United States Army
The Adjutant General

DISTRIBUTION:

To be distributed in accordance with DA Form 12-31, Operator, Organizational, Direct Support and General Support Maintenance requirements for all Fixed and Rotor Wing Aircraft.

RECOMMENDED CHANGES TO EQUIPMENT TECHNICAL PUBLICATIONS



THEN... JOT DOWN THE DOPE ABOUT IT ON THIS FORM. CAREFULLY TEAR IT OUT, FOLD IT AND DROP IT IN THE MAIL!

SOMETHING WRONG WITH THIS PUBLICATION?

FROM: (PRINT YOUR UNIT'S COMPLETE ADDRESS)
PFC JOHN DOE
COA, 3d ENGINEER BN
FT. LEONARDWOOD, MO 63108
 DATE SENT

PUBLICATION NUMBER: **TM 55-4920-439-13&P**
 PUBLICATION DATE: **13 May 1985**
 PUBLICATION TITLE: **Operator's and AVIM Manual Including RPSTL for ELECTRIC/INSTRUMENT SHOP**

BE EXACT... PIN-POINT WHERE IT IS

PAGE NO.	PARA-GRAPH	FIGURE NO.	TABLE NO.
6	2-1 a		
B1		4-3	
125	line 20		

IN THIS SPACE TELL WHAT IS WRONG AND WHAT SHOULD BE DONE ABOUT IT:

In line 6 of paragraph 2-1 a the manual states the engine has 6 Cylinders. The engine on my set only has 4 Cylinders. Change the manual to show 4 Cylinders.

Callout 16 on figure 4-3 is pointing at a bolt. In key to figure 4-3, item 16 is called a shim - Please correct one or the other.

I ordered a gasket, item 19 on figure B-16 by NSN 2 910-05-762-3001. I got a gasket but it doesn't fit. Supply says I got what I ordered, so the NSN is wrong. Please give me a good NSN

PRINTED NAME, GRADE OR TITLE, AND TELEPHONE NUMBER
JOHN DOE, PFC (268) 317.7111

SIGN HERE
JOHN DOE

TEAR ALONG PERFORATED LINE

REVERSE OF DA FORM 2028-2

Reverse of DRSTS-M Overprint 1,
1 Nov 80

FILL IN YOUR
UNIT'S ADDRESS

FOLD BACK

DEPARTMENT OF THE ARMY

OFFICIAL BUSINESS

COMMANDER
U S ARMY AVIATION SYSTEMS COMMAND
ATTN: AMSAV-MPSD
4300 GOODFELLOW BOULEVARD
ST. LOUIS, MO 63120-1798

TEAR ALONG PERFORATED LINE

RECOMMENDED CHANGES TO EQUIPMENT TECHNICAL PUBLICATIONS

 <p style="text-align: center;">SOMETHING WRONG WITH THIS PUBLICATION?</p> <p style="font-size: small;">THEN... JOT DOWN THE DOPE ABOUT IT ON THIS FORM, CAREFULLY TEAR IT OUT, FOLD IT AND DROP IT IN THE MAIL!</p>		FROM: (PRINT YOUR UNIT'S COMPLETE ADDRESS)		
		DATE SENT		
PUBLICATION NUMBER TM 55-4920-439-13&P		PUBLICATION DATE 13 May 1985		
PUBLICATION TITLE Operator's and AVIM Manual Including RPSTL for ELECTRIC/INSTRUMENT SHOP				
BE EXACT... PIN-POINT WHERE IT IS				
PAGE NO	PARA-GRAPH	FIGURE NO	TABLE NO	<p>IN THIS SPACE TELL WHAT IS WRONG AND WHAT SHOULD BE DONE ABOUT IT:</p>
PRINTED NAME, GRADE OR TITLE, AND TELEPHONE NUMBER			SIGN HERE:	

TEAR ALONG PERFORATED LINE

REVERSE OF DA FORM 2028-2

Reverse of DRSTS-M Overprint 1,
1 Nov 80

FILL IN YOUR
UNIT'S ADDRESS

FOLD BACK

DEPARTMENT OF THE ARMY

OFFICIAL BUSINESS

COMMANDER
U S ARMY AVIATION SYSTEMS COMMAND
ATTN: AMSAV-MPSD
4300 GOODFELLOW BOULEVARD
ST. LOUIS, MO 63120-1798

TEAR ALONG PERFORATED LINE

The Metric System and Equivalents

Linear Measure

1 centimeter = 10 millimeters = .39 inch
 1 decimeter = 10 centimeters = 3.94 inches
 1 meter = 10 decimeters = 39.37 inches
 1 dekameter = 10 Meters = 32.8 feet
 1 hectometer = 10 dekameters = 328.08 feet
 1 kilometer = 10 hectometers = 3,280.8 feet

Weights

1 centigram = 10 milligrams = .15 grain
 1 decigram = 10 centigrams = 1.54 grains
 1 gram = 10 decigram = 0.35 ounce
 1 dekagram = 10 Grams = .35 ounce
 1 hectogram = 10 dekagrams = 3.52 ounces
 1 kilogram = 10 hectograms = 2.2 pounds
 1 quintal = 100 kilograms = 220.46 pounds
 1 metric ton = 10 quintals = 1.1 short tons

Liquid Measure

1 centiliter = 10 milliliters = .34 fluid ounce
 1 deciliter = 10 centiliters = 3.38 fluid ounces
 1 liter = 10 deciliters = 33.81 fluid ounces
 1 dekaliter = 10 liters = 2.64 gallons
 1 hectoliter = 10 dekaliters = 27.42 gallons
 1 kiloliter = 10 hectoliters = 264.18 gallons

Square Measure

1 sq. centimeter = 100 sq millimeters = .155 sq. inch
 1 sq. decimeter = 100 sq centimeters = 125.5 sq. inches
 1 sq. meter (centare) = 100 sq decimeters = 10.76 sq. feet
 1 sq. dekameter (are) = 1,076.4 sq. feet
 1 sq. hectometer (hectare) = 100 sq. dekameters = 2.47 acres
 1 sq. kilometer = 100 sq. hectometers = .386 sq. mile

Cubic Measure

1 cu. centimeter = 1000 cu. millimeters = .06 cu. inch
 1 cu. decimeter = 1000 cu. decimeters = 61.02 cu. inches
 1 cu. meter = 1000 cu. decimeters = 35.31 cu. feet

Approximate Conversion Factors

<i>To change</i>	<i>To</i>	<i>Multiply by</i>	<i>To change</i>	<i>To</i>	<i>Multiply by</i>
inches	centimeters	2.540	ounce-inches	newton-meters	.007062
feet	meters	.305	centimeters	inches	.394
yards	meters	.914	meters	feet	3.280
miles	kilometers	1.609	meters	yards	1.094
square inches	square centimeters	6.451	kilometers	miles	.621
square feet	square meters	.093	square centimeters	square inches	.155
square yards	square meters	.836	square meters	square feet	10.764
square miles	square kilometers	2.590	square meters	square yards	1.196
acres	square hectometers	.405	square kilometers	square miles	.386
cubic feet	cubic meters	.028	square hectometers	acres	2.471
cubic yards	cubic meters	.765	cubic meters	cubic feet	35.315
fluid ounces	milliliters	29.573	cubic meters	cubic yards	1.308
pints	liters	.473	milliliters	fluid ounces	.034
quarts	liters	.946	liters	pints	2.113
gallons	liters	3.785	liters	quarts	1.057
ounces	grams	28.349	liters	gallons	.264
pounds	kilograms	.454	grams	ounces	.035
short tons	metric tons	.907	kilograms	pounds	2.205
pound-feet	newton-meters	1.356	metric tons	short tons	1.102
pounds-inches	newton-meters	.11296			

Temperature (Exact)

°F	Fahrenheit	5/9 (after	Celsius	°C
	temperature	subtracting 32)	temperature	

TM 55-4920-439-13&P

PIN: 057554-002